



wwPDB EM Validation Summary Report ⓘ

Feb 26, 2024 – 05:02 AM EST

PDB ID : 6WJ6
EMDB ID : EMD-21690
Title : Cryo-EM structure of apo-Photosystem II from Synechocystis sp. PCC 6803
Authors : Gisriel, C.J.
Deposited on : 2020-04-12
Resolution : 2.58 Å (reported)

This is a wwPDB EM Validation Summary Report for a publicly released PDB entry.

We welcome your comments at validation@mail.wwpdb.org

A user guide is available at

<https://www.wwpdb.org/validation/2017/EMValidationReportHelp>

with specific help available everywhere you see the ⓘ symbol.

The types of validation reports are described at

<http://www.wwpdb.org/validation/2017/FAQs#types>.

The following versions of software and data (see [references ⓘ](#)) were used in the production of this report:

EMDB validation analysis : 0.0.1.dev70
Mogul : 1.8.5 (274361), CSD as541be (2020)
MolProbity : 4.02b-467
buster-report : 1.1.7 (2018)
Percentile statistics : 20191225.v01 (using entries in the PDB archive December 25th 2019)
MapQ : 1.9.13
Ideal geometry (proteins) : Engh & Huber (2001)
Ideal geometry (DNA, RNA) : Parkinson et al. (1996)
Validation Pipeline (wwPDB-VP) : 2.36

1 Overall quality at a glance

The following experimental techniques were used to determine the structure:

ELECTRON MICROSCOPY

The reported resolution of this entry is 2.58 Å.

Percentile scores (ranging between 0-100) for global validation metrics of the entry are shown in the following graphic. The table shows the number of entries on which the scores are based.

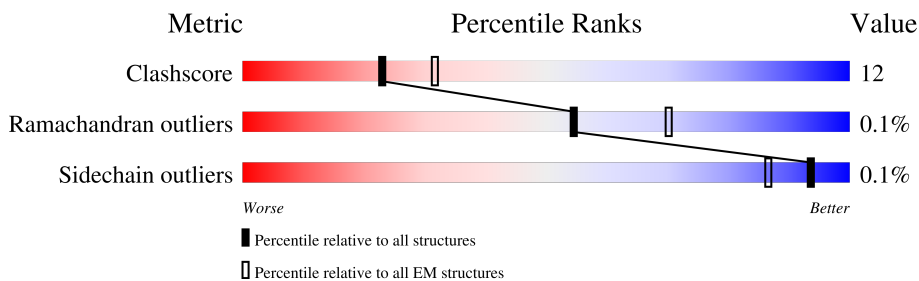





Metric	Whole archive (#Entries)	EM structures (#Entries)
Clashscore	158937	4297
Ramachandran outliers	154571	4023
Sidechain outliers	154315	3826

The table below summarises the geometric issues observed across the polymeric chains and their fit to the map. The red, orange, yellow and green segments of the bar indicate the fraction of residues that contain outliers for ≥ 3 , 2, 1 and 0 types of geometric quality criteria respectively. A grey segment represents the fraction of residues that are not modelled. The numeric value for each fraction is indicated below the corresponding segment, with a dot representing fractions $\leq 5\%$. The upper red bar (where present) indicates the fraction of residues that have poor fit to the EM map (all-atom inclusion $< 40\%$). The numeric value is given above the bar.

Mol	Chain	Length	Quality of chain
1	A	360	
2	B	507	
3	C	460	
4	D	352	
5	E	81	
6	F	44	
7	H	64	
8	I	38	

Continued on next page...

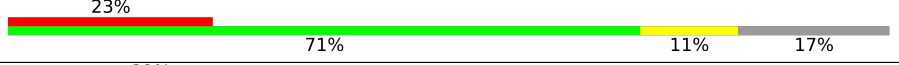
Continued from previous page...

Mol	Chain	Length	Quality of chain
9	K	45	
10	L	39	
11	M	35	
12	T	31	
13	X	39	

The following table lists non-polymeric compounds, carbohydrate monomers and non-standard residues in protein, DNA, RNA chains that are outliers for geometric or electron-density-fit criteria:

Mol	Type	Chain	Res	Chirality	Geometry	Clashes	Electron density
15	CLA	A	402	X	-	-	-
15	CLA	A	403	X	-	-	-
15	CLA	A	405	X	-	-	-
15	CLA	B	601	X	-	-	-
15	CLA	B	602	X	-	-	-
15	CLA	B	603	X	-	-	-
15	CLA	B	604	X	-	-	-
15	CLA	B	605	X	-	-	-
15	CLA	B	606	X	-	-	-
15	CLA	B	607	X	-	-	-
15	CLA	B	608	X	-	-	-
15	CLA	B	609	X	-	-	-
15	CLA	B	610	X	-	-	-
15	CLA	B	611	X	-	-	-
15	CLA	B	612	X	-	-	-
15	CLA	B	613	X	-	-	-
15	CLA	B	614	X	-	-	-
15	CLA	B	615	X	-	-	-
15	CLA	B	616	X	-	-	-
15	CLA	C	502	X	-	-	-
15	CLA	C	503	X	-	-	-
15	CLA	C	504	X	-	-	-
15	CLA	C	505	X	-	-	-
15	CLA	C	506	X	-	-	-
15	CLA	C	507	X	-	-	-
15	CLA	C	508	X	-	-	-
15	CLA	C	509	X	-	-	-
15	CLA	C	510	X	-	-	-

Continued on next page...

Continued from previous page...

Mol	Type	Chain	Res	Chirality	Geometry	Clashes	Electron density
15	CLA	C	511	X	-	-	-
15	CLA	C	512	X	-	-	-
15	CLA	C	513	X	-	-	-
15	CLA	C	514	X	-	-	-
15	CLA	D	402	X	-	-	-
15	CLA	D	405	X	-	-	-
15	CLA	D	406	X	-	-	-

2 Entry composition i

There are 28 unique types of molecules in this entry. The entry contains 18884 atoms, of which 0 are hydrogens and 0 are deuteriums.

In the tables below, the AltConf column contains the number of residues with at least one atom in alternate conformation and the Trace column contains the number of residues modelled with at most 2 atoms.

- Molecule 1 is a protein called Photosystem II protein D1 2.

Mol	Chain	Residues	Atoms					AltConf	Trace
			Total	C	N	O	S		
1	A	302	2357	1552	386	404	15	0	0

- Molecule 2 is a protein called Photosystem II CP47 reaction center protein.

Mol	Chain	Residues	Atoms					AltConf	Trace
			Total	C	N	O	S		
2	B	478	3751	2454	628	656	13	0	0

- Molecule 3 is a protein called Photosystem II CP43 reaction center protein.

Mol	Chain	Residues	Atoms					AltConf	Trace
			Total	C	N	O	S		
3	C	415	3259	2151	542	553	13	0	0

There is a discrepancy between the modelled and reference sequences:

Chain	Residue	Modelled	Actual	Comment	Reference
C	18	SER	THR	conflict	UNP P09193

- Molecule 4 is a protein called Photosystem II D2 protein.

Mol	Chain	Residues	Atoms					AltConf	Trace
			Total	C	N	O	S		
4	D	342	2734	1812	444	466	12	0	0

- Molecule 5 is a protein called Cytochrome b559 subunit alpha.

Mol	Chain	Residues	Atoms					AltConf	Trace
			Total	C	N	O	S		
5	E	72	603	396	95	111	1	0	0

- Molecule 6 is a protein called Cytochrome b559 subunit beta.

Mol	Chain	Residues	Atoms					AltConf	Trace
6	F	32	Total	C	N	O	S	0	0
			255	173	43	38	1		

- Molecule 7 is a protein called Photosystem II reaction center protein H.

Mol	Chain	Residues	Atoms					AltConf	Trace
7	H	63	Total	C	N	O	S	0	0
			494	328	79	85	2		

- Molecule 8 is a protein called Photosystem II reaction center protein I.

Mol	Chain	Residues	Atoms				AltConf	Trace
8	I	35	Total	C	N	O	0	0
			276	186	44	46		

- Molecule 9 is a protein called Photosystem II reaction center protein K.

Mol	Chain	Residues	Atoms				AltConf	Trace
9	K	35	Total	C	N	O	0	0
			278	195	39	44		

- Molecule 10 is a protein called Photosystem II reaction center protein L.

Mol	Chain	Residues	Atoms				AltConf	Trace
10	L	31	Total	C	N	O	0	0
			252	169	40	43		

- Molecule 11 is a protein called Photosystem II reaction center protein M.

Mol	Chain	Residues	Atoms				AltConf	Trace
11	M	29	Total	C	N	O	0	0
			226	157	33	36		

- Molecule 12 is a protein called Photosystem II reaction center protein T.

Mol	Chain	Residues	Atoms					AltConf	Trace
12	T	29	Total	C	N	O	S	0	0
			231	157	35	38	1		

- Molecule 13 is a protein called Photosystem II reaction center X protein.

Mol	Chain	Residues	Atoms					AltConf	Trace
			Total	C	N	O	S		
13	X	35	262	177	40	44	1	0	0

- Molecule 14 is FE (II) ION (three-letter code: FE2) (formula: Fe).

Mol	Chain	Residues	Atoms		AltConf
			Total	Fe	
14	A	1	1	1	0

- Molecule 15 is CHLOROPHYLL A (three-letter code: CLA) (formula: C₅₅H₇₂MgN₄O₅) (labeled as "Ligand of Interest" by depositor).

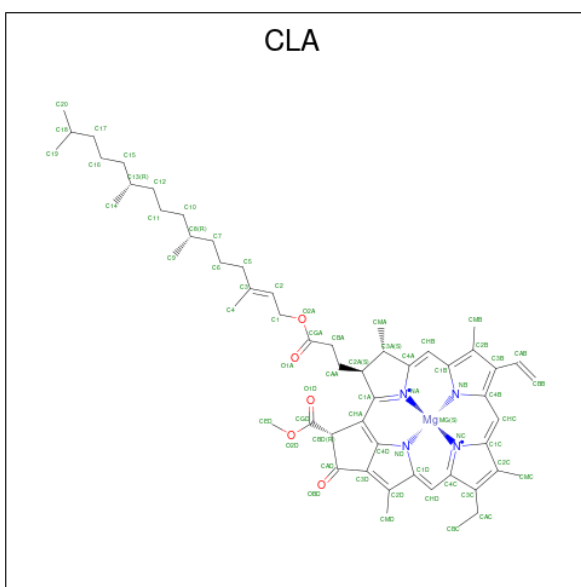

Mol	Chain	Residues	Atoms					AltConf
			Total	C	Mg	N	O	
15	A	1	65	55	1	4	5	0
15	A	1	55	45	1	4	5	0
15	A	1	50	40	1	4	5	0
15	B	1	65	55	1	4	5	0
15	B	1	65	55	1	4	5	0
15	B	1	65	55	1	4	5	0
15	B	1	65	55	1	4	5	0

Continued on next page...

Continued from previous page...

Mol	Chain	Residues	Atoms					AltConf
			Total	C	Mg	N	O	
15	B	1	65	55	1	4	5	0
15	B	1	60	50	1	4	5	0
15	B	1	65	55	1	4	5	0
15	B	1	65	55	1	4	5	0
15	B	1	65	55	1	4	5	0
15	B	1	65	55	1	4	5	0
15	B	1	65	55	1	4	5	0
15	B	1	65	55	1	4	5	0
15	B	1	65	55	1	4	5	0
15	B	1	55	45	1	4	5	0
15	B	1	65	55	1	4	5	0
15	B	1	50	40	1	4	5	0
15	C	1	65	55	1	4	5	0
15	C	1	65	55	1	4	5	0
15	C	1	65	55	1	4	5	0
15	C	1	65	55	1	4	5	0
15	C	1	65	55	1	4	5	0
15	C	1	65	55	1	4	5	0
15	C	1	65	55	1	4	5	0
15	C	1	55	45	1	4	5	0
15	C	1	65	55	1	4	5	0

Continued on next page...

Continued from previous page...

Mol	Chain	Residues	Atoms					AltConf
15	C	1	Total	C	Mg	N	O	0
			65	55	1	4	5	
15	C	1	Total	C	Mg	N	O	0
			45	35	1	4	5	
15	C	1	Total	C	Mg	N	O	0
			65	55	1	4	5	
15	C	1	Total	C	Mg	N	O	0
			65	55	1	4	5	
15	D	1	Total	C	Mg	N	O	0
			65	55	1	4	5	
15	D	1	Total	C	Mg	N	O	0
			65	55	1	4	5	
15	D	1	Total	C	Mg	N	O	0
			65	55	1	4	5	

- Molecule 16 is PHEOPHYTIN A (three-letter code: PHO) (formula: $C_{55}H_{74}N_4O_5$).

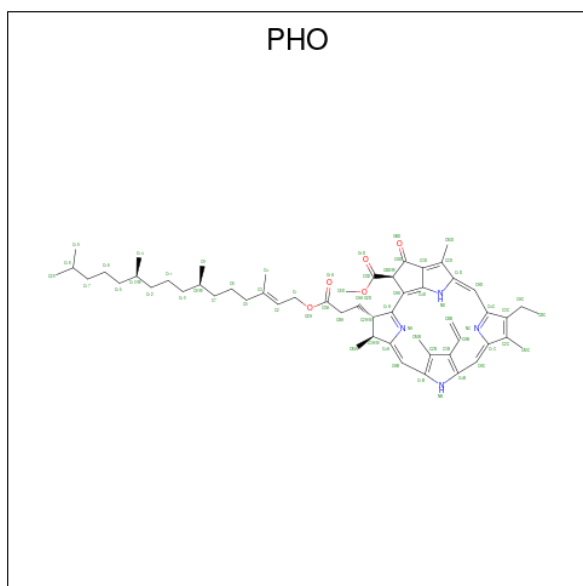

Mol	Chain	Residues	Atoms				AltConf
16	A	1	Total	C	N	O	0
			64	55	4	5	
16	D	1	Total	C	N	O	0
			64	55	4	5	

- Molecule 17 is BETA-CAROTENE (three-letter code: BCR) (formula: $C_{40}H_{56}$).

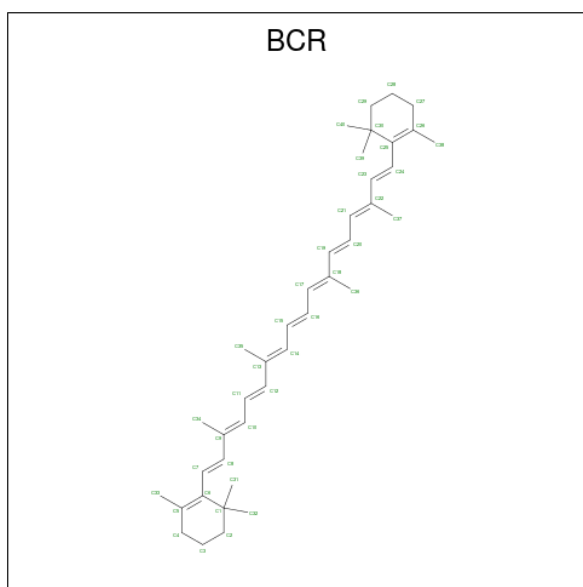

Mol	Chain	Residues	Atoms	AltConf
17	A	1	Total C 40 40	0
17	B	1	Total C 40 40	0
17	B	1	Total C 40 40	0
17	B	1	Total C 40 40	0
17	C	1	Total C 40 40	0
17	C	1	Total C 40 40	0
17	C	1	Total C 40 40	0
17	D	1	Total C 40 40	0
17	X	1	Total C 40 40	0

- Molecule 18 is 1,2-DI-O-ACYL-3-O-[6-DEOXY-6-SULFO-ALPHA-D-GLUCOPYRANOSYL]-SN-GLYCEROL (three-letter code: SQD) (formula: C₄₁H₇₈O₁₂S).

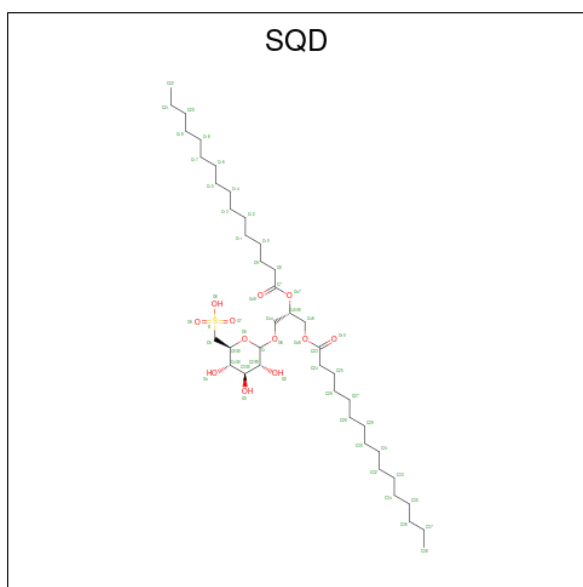

Mol	Chain	Residues	Atoms				AltConf
			Total	C	O	S	
18	A	1	48	35	12	1	0
18	A	1	54	41	12	1	0
18	B	1	51	38	12	1	0
18	C	1	54	41	12	1	0
18	T	1	52	39	12	1	0
18	T	1	41	28	12	1	0
18	X	1	42	29	12	1	0

- Molecule 19 is 2,3-DIMETHYL-5-(3,7,11,15,19,23,27,31,35-NONAMETHYL-2,6,10,14,18,22,26,30,34-HEXATRIACONTANONAENYL-2,5-CYCLOHEXADIENE-1,4-DIONE-2,3-DIMETHYL-5-SOLANESYL-1,4-BENZOQUINONE (three-letter code: PL9) (formula: $C_{53}H_{80}O_2$).

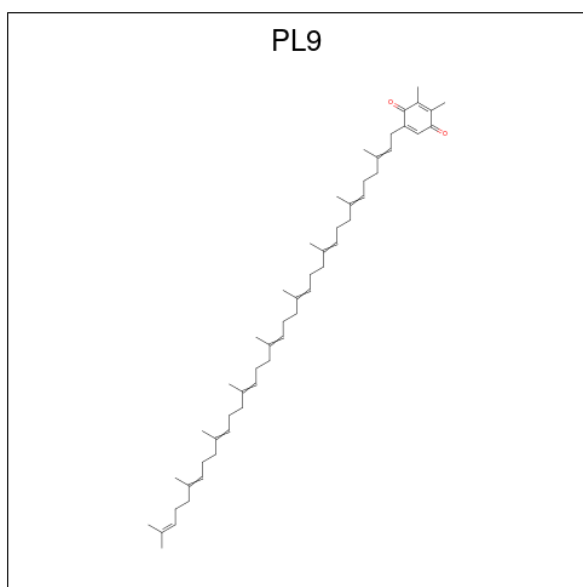

Mol	Chain	Residues	Atoms			AltConf
19	A	1	Total	C	O	0
			15	13	2	
19	D	1	Total	C	O	0
			55	53	2	

- Molecule 20 is 1,2-DISTEAROYL-MONOGALACTOSYL-DIGLYCERIDE (three-letter code: LMG) (formula: C₄₅H₈₆O₁₀).

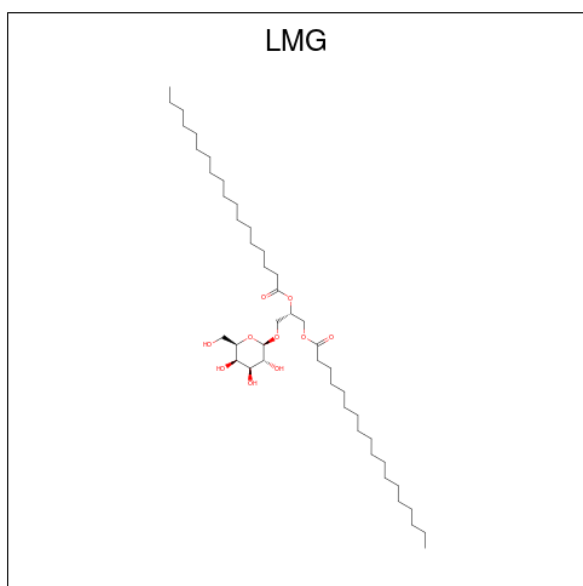

Mol	Chain	Residues	Atoms			AltConf
20	B	1	Total	C	O	0
			51	41	10	

Continued on next page...

Continued from previous page...

Mol	Chain	Residues	Atoms			AltConf
			Total	C	O	
20	C	1	51	41	10	0
20	D	1	51	41	10	0

- Molecule 21 is DODECYL-BETA-D-MALTOSE (three-letter code: LMT) (formula: $C_{24}H_{46}O_{11}$).

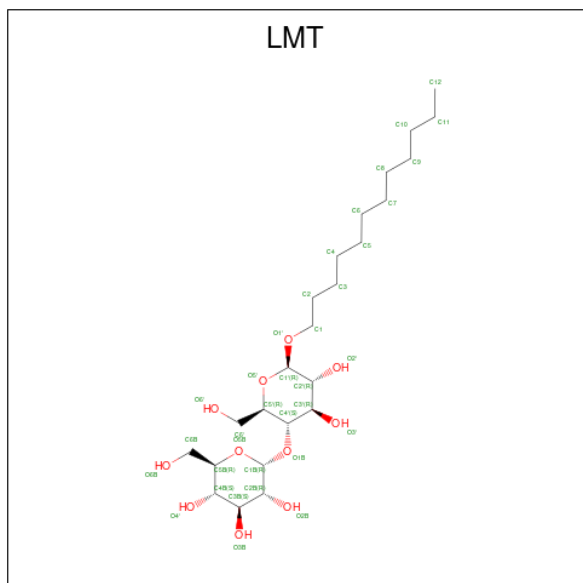

Mol	Chain	Residues	Atoms			AltConf
			Total	C	O	
21	B	1	35	24	11	0
21	B	1	34	23	11	0

- Molecule 22 is DIGALACTOSYL DIACYL GLYCEROL (DGDG) (three-letter code: DGD) (formula: $C_{51}H_{96}O_{15}$).

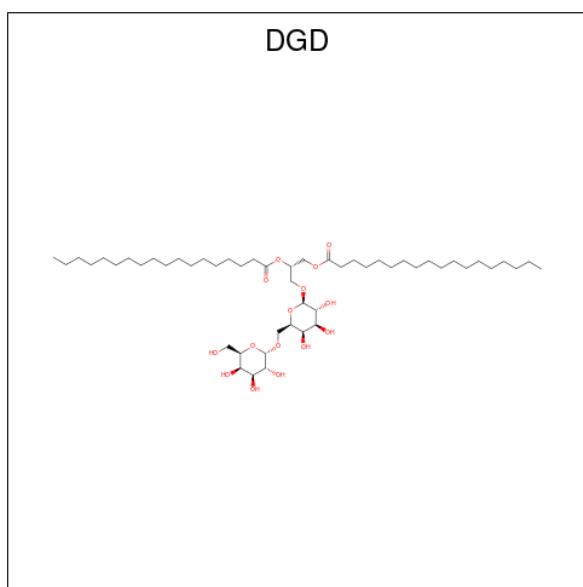

Mol	Chain	Residues	Atoms			AltConf
			Total	C	O	
22	C	1	62	47	15	0
22	H	1	62	47	15	0

- Molecule 23 is CHLORIDE ION (three-letter code: CL) (formula: Cl).

Mol	Chain	Residues	Atoms		AltConf
			Total	Cl	
23	D	1	1	1	0

- Molecule 24 is BICARBONATE ION (three-letter code: BCT) (formula: CHO₃).

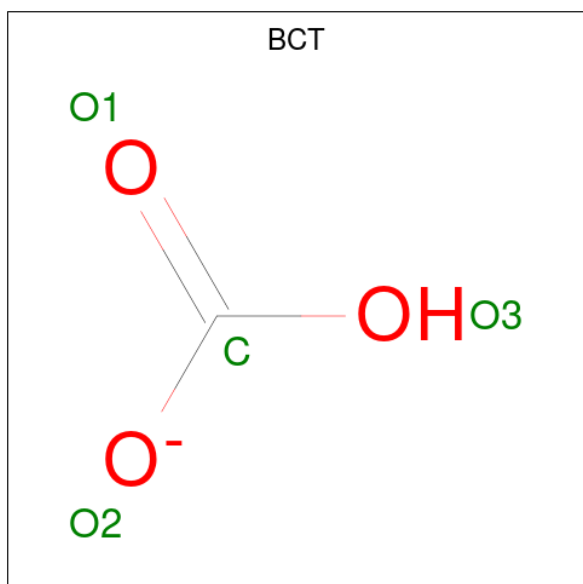

Mol	Chain	Residues	Atoms			AltConf
24	D	1	Total	C	O	0
			4	1	3	

- Molecule 25 is 1,2-DIPALMITOYL-PHOSPHATIDYL-GLYCEROLE (three-letter code: LHG) (formula: $C_{38}H_{75}O_{10}P$).

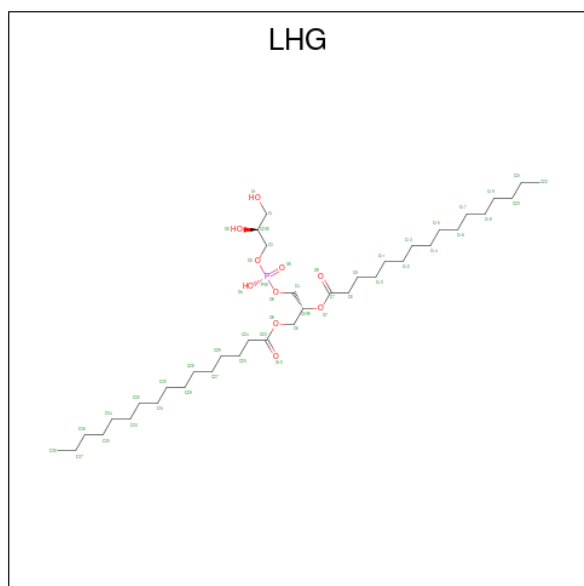

Mol	Chain	Residues	Atoms				AltConf
25	D	1	Total	C	O	P	0
			49	38	10	1	
25	D	1	Total	C	O	P	0
			49	38	10	1	
25	D	1	Total	C	O	P	0
			46	35	10	1	
25	L	1	Total	C	O	P	0
			49	38	10	1	

- Molecule 26 is PROTOPORPHYRIN IX CONTAINING FE (three-letter code: HEM) (formula: $C_{34}H_{32}FeN_4O_4$).

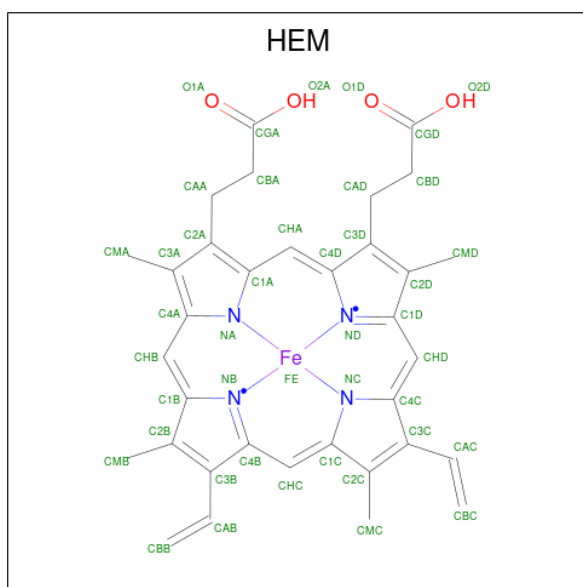

Mol	Chain	Residues	Atoms					AltConf
			Total	C	Fe	N	O	
26	E	1	43	34	1	4	4	0

- Molecule 27 is N-FORMYLMETHIONINE (three-letter code: FME) (formula: $C_6H_{11}NO_3S$).

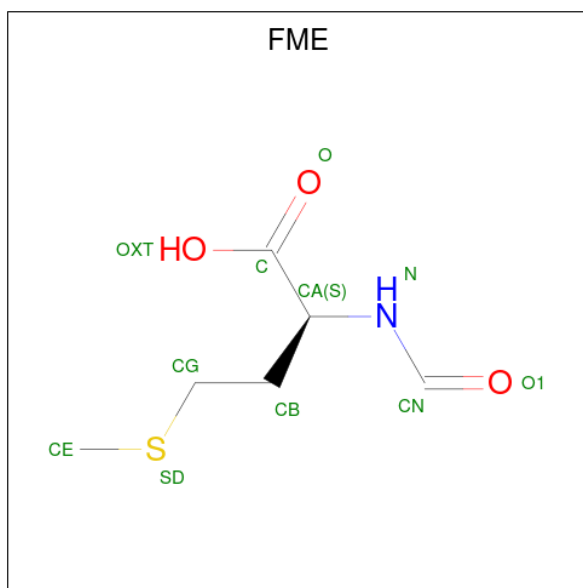

Mol	Chain	Residues	Atoms					AltConf
			Total	C	N	O	S	
27	I	1	10	6	1	2	1	0
27	M	1	10	6	1	2	1	0
27	T	1	10	6	1	2	1	0

- Molecule 28 is water.

Mol	Chain	Residues	Atoms	AltConf
28	A	54	Total O 54 54	0
28	B	62	Total O 62 62	0
28	C	30	Total O 30 30	0
28	D	46	Total O 46 46	0
28	E	2	Total O 2 2	0
28	L	1	Total O 1 1	0
28	T	2	Total O 2 2	0
28	X	1	Total O 1 1	0

3 Residue-property plots

These plots are drawn for all protein, RNA, DNA and oligosaccharide chains in the entry. The first graphic for a chain summarises the proportions of the various outlier classes displayed in the second graphic. The second graphic shows the sequence view annotated by issues in geometry and atom inclusion in map density. Residues are color-coded according to the number of geometric quality criteria for which they contain at least one outlier: green = 0, yellow = 1, orange = 2 and red = 3 or more. A red diamond above a residue indicates a poor fit to the EM map for this residue (all-atom inclusion < 40%). Stretches of 2 or more consecutive residues without any outlier are shown as a green connector. Residues present in the sample, but not in the model, are shown in grey.

- Molecule 1: Photosystem II protein D1 2

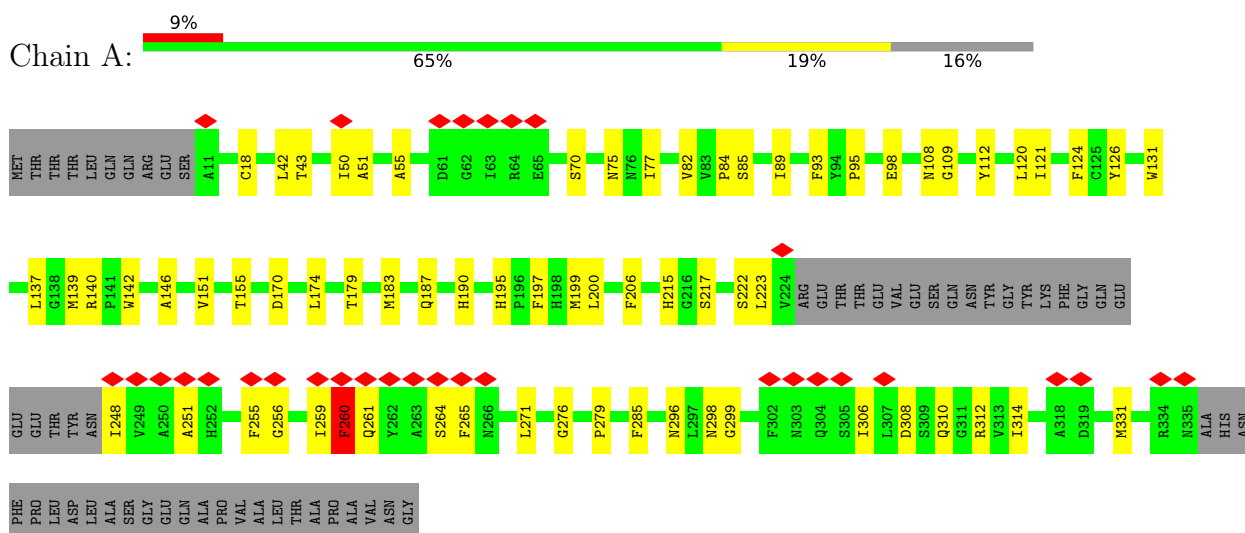

- Molecule 2: Photosystem II CP47 reaction center protein

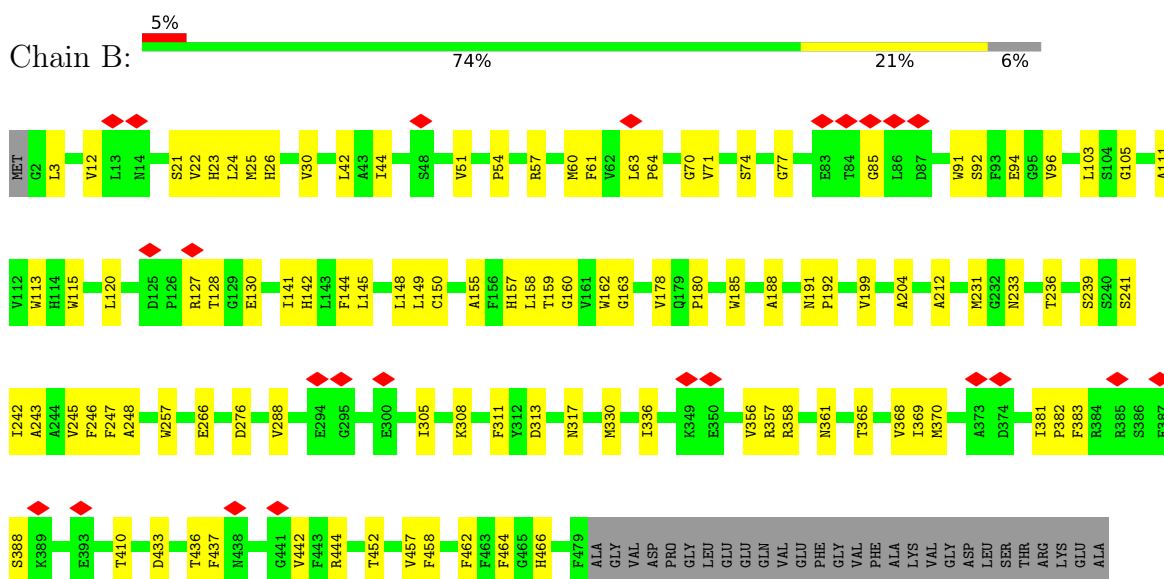

- Molecule 3: Photosystem II CP43 reaction center protein

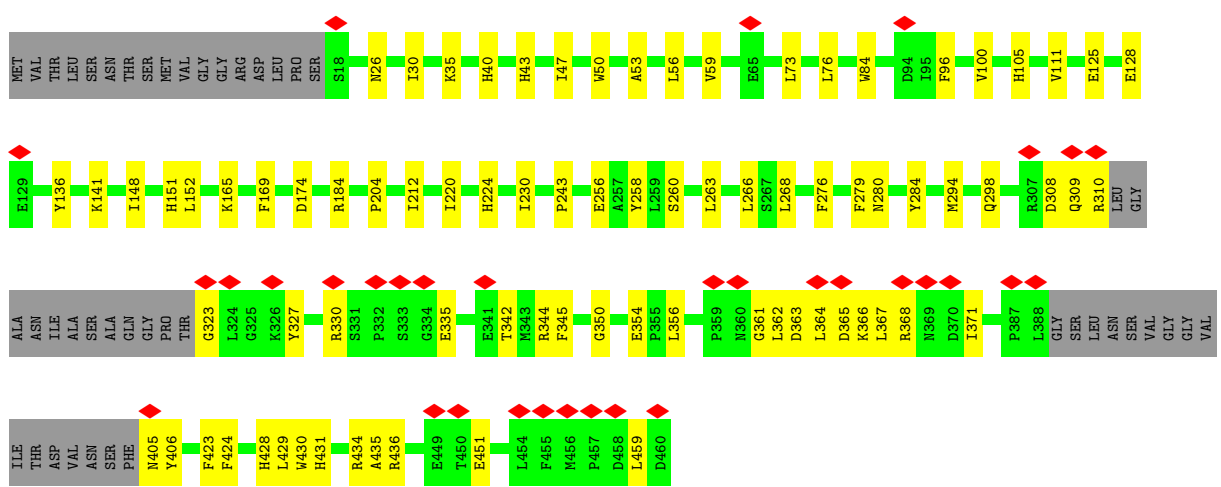
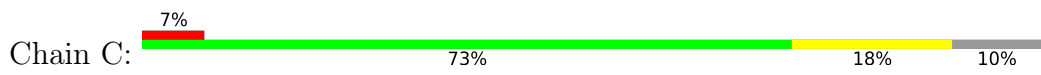

• Molecule 4: Photosystem II D2 protein

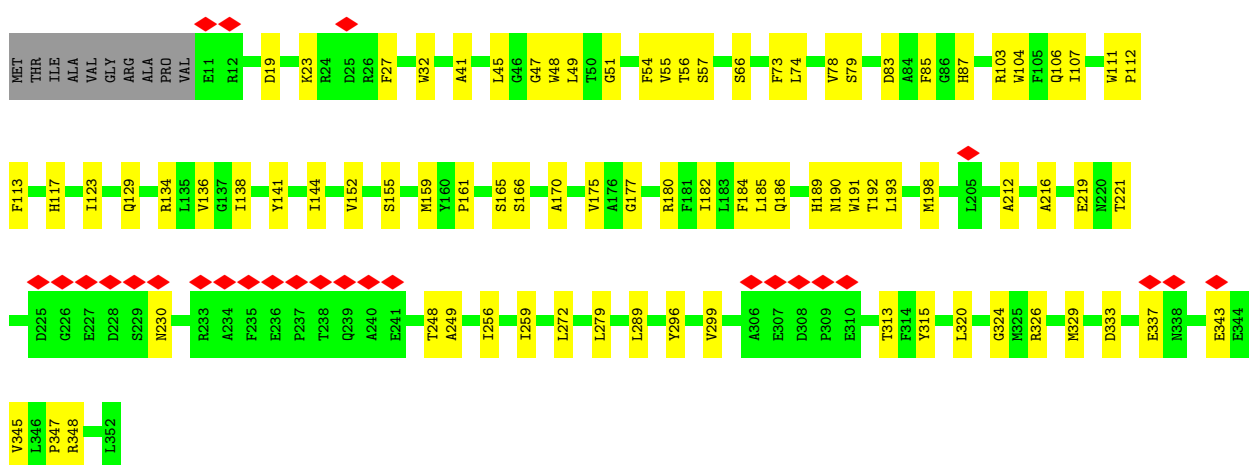
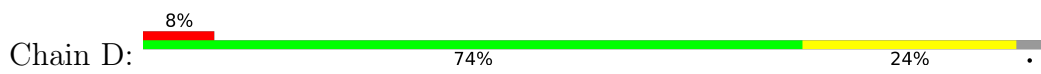

• Molecule 5: Cytochrome b559 subunit alpha

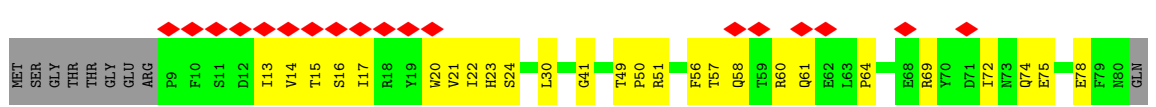

• Molecule 6: Cytochrome b559 subunit beta

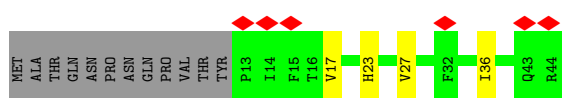

- Molecule 7: Photosystem II reaction center protein H

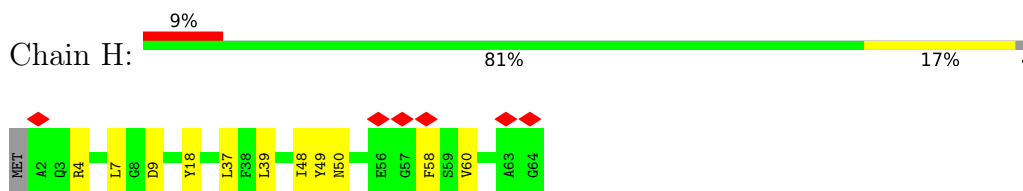

- Molecule 8: Photosystem II reaction center protein I

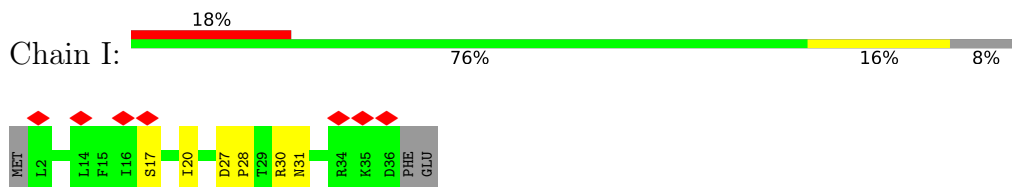

- Molecule 9: Photosystem II reaction center protein K

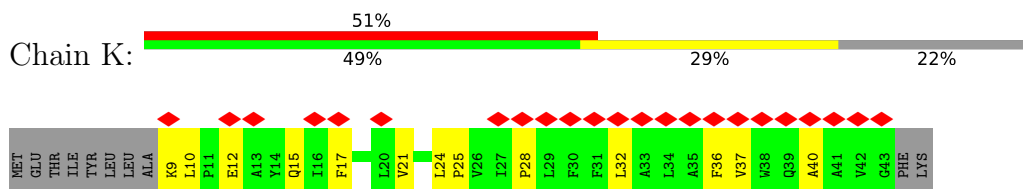

- Molecule 10: Photosystem II reaction center protein L

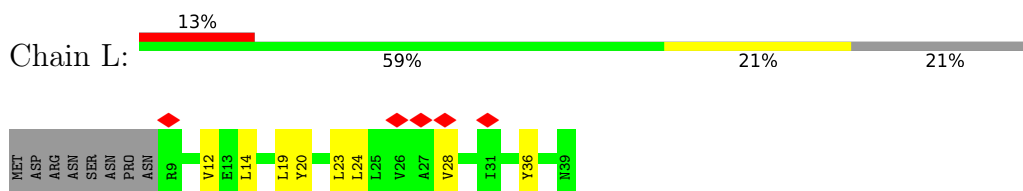

- Molecule 11: Photosystem II reaction center protein M

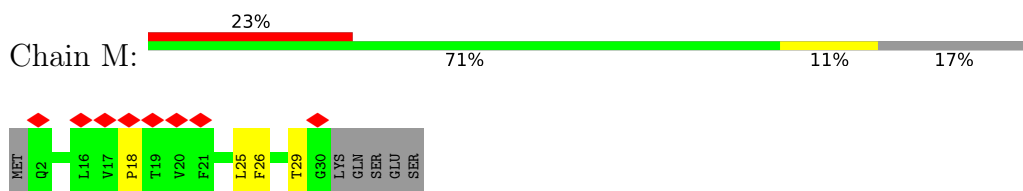

- Molecule 12: Photosystem II reaction center protein T

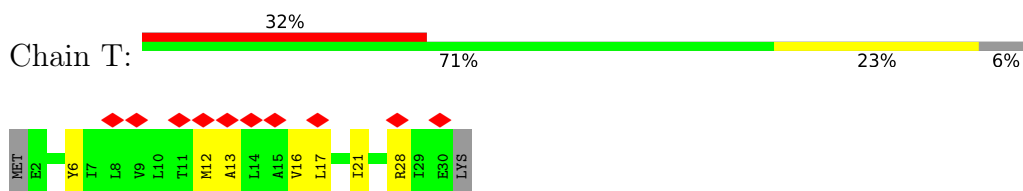

- Molecule 13: Photosystem II reaction center X protein



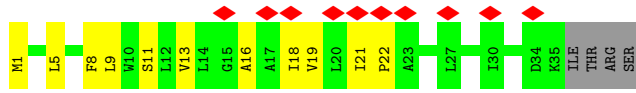

4 Experimental information

Property	Value	Source
EM reconstruction method	SINGLE PARTICLE	Depositor
Imposed symmetry	POINT, C1	Depositor
Number of particles used	212640	Depositor
Resolution determination method	FSC 0.143 CUT-OFF	Depositor
CTF correction method	NONE	Depositor
Microscope	FEI TITAN KRIOS	Depositor
Voltage (kV)	300	Depositor
Electron dose ($e^-/\text{\AA}^2$)	48.07	Depositor
Minimum defocus (nm)	Not provided	
Maximum defocus (nm)	Not provided	
Magnification	Not provided	
Image detector	GATAN K2 SUMMIT (4k x 4k)	Depositor
Maximum map value	0.243	Depositor
Minimum map value	-0.114	Depositor
Average map value	-0.000	Depositor
Map value standard deviation	0.008	Depositor
Recommended contour level	0.0394	Depositor
Map size (\AA)	302.4, 302.4, 302.4	wwPDB
Map dimensions	256, 256, 256	wwPDB
Map angles ($^\circ$)	90.0, 90.0, 90.0	wwPDB
Pixel spacing (\AA)	1.18125, 1.18125, 1.18125	Depositor

5 Model quality

5.1 Standard geometry

Bond lengths and bond angles in the following residue types are not validated in this section: LMG, SQD, PL9, FME, CLA, BCT, FE2, CL, LMT, DGD, PHO, HEM, LHG, BCR

The Z score for a bond length (or angle) is the number of standard deviations the observed value is removed from the expected value. A bond length (or angle) with $|Z| > 5$ is considered an outlier worth inspection. RMSZ is the root-mean-square of all Z scores of the bond lengths (or angles).

Mol	Chain	Bond lengths		Bond angles	
		RMSZ	# Z >5	RMSZ	# Z >5
1	A	0.29	0/2434	0.42	0/3319
2	B	0.30	0/3881	0.42	0/5285
3	C	0.28	0/3369	0.41	0/4582
4	D	0.30	0/2831	0.42	0/3855
5	E	0.30	0/622	0.44	0/849
6	F	0.27	0/263	0.42	0/357
7	H	0.29	0/506	0.45	0/687
8	I	0.27	0/282	0.45	0/381
9	K	0.28	0/288	0.46	0/397
10	L	0.29	0/257	0.38	0/347
11	M	0.27	0/230	0.37	0/314
12	T	0.27	0/236	0.40	0/321
13	X	0.25	0/267	0.38	0/364
All	All	0.29	0/15466	0.42	0/21058

Chiral center outliers are detected by calculating the chiral volume of a chiral center and verifying if the center is modelled as a planar moiety or with the opposite hand. A planarity outlier is detected by checking planarity of atoms in a peptide group, atoms in a mainchain group or atoms of a sidechain that are expected to be planar.

Mol	Chain	#Chirality outliers	#Planarity outliers
1	A	0	1

There are no bond length outliers.

There are no bond angle outliers.

There are no chirality outliers.

All (1) planarity outliers are listed below:

Mol	Chain	Res	Type	Group
1	A	260	PHE	Peptide

5.2 Too-close contacts [i](#)

In the following table, the Non-H and H(model) columns list the number of non-hydrogen atoms and hydrogen atoms in the chain respectively. The H(added) column lists the number of hydrogen atoms added and optimized by MolProbity. The Clashes column lists the number of clashes within the asymmetric unit, whereas Symm-Clashes lists symmetry-related clashes.

Mol	Chain	Non-H	H(model)	H(added)	Clashes	Symm-Clashes
1	A	2357	0	2284	56	0
2	B	3751	0	3598	84	0
3	C	3259	0	3186	65	0
4	D	2734	0	2623	66	0
5	E	603	0	578	19	0
6	F	255	0	265	4	0
7	H	494	0	508	10	0
8	I	276	0	293	4	0
9	K	278	0	286	10	0
10	L	252	0	262	11	0
11	M	226	0	246	7	0
12	T	231	0	243	4	0
13	X	262	0	289	7	0
14	A	1	0	0	0	0
15	A	170	0	158	10	0
15	B	1010	0	1078	77	0
15	C	815	0	870	65	0
15	D	195	0	216	16	0
16	A	64	0	74	6	0
16	D	64	0	74	4	0
17	A	40	0	49	5	0
17	B	120	0	147	11	0
17	C	120	0	147	13	0
17	D	40	0	49	3	0
17	X	40	0	49	7	0
18	A	102	0	141	8	0
18	B	51	0	69	4	0
18	C	54	0	78	5	0
18	T	93	0	117	6	0
18	X	42	0	48	4	0
19	A	15	0	13	1	0
19	D	55	0	80	0	0
20	B	51	0	72	3	0

Continued on next page...

Continued from previous page...

Mol	Chain	Non-H	H(model)	H(added)	Clashes	Symm-Clashes
20	C	51	0	72	8	0
20	D	51	0	72	2	0
21	B	69	0	85	8	0
22	C	62	0	82	2	0
22	H	62	0	82	4	0
23	D	1	0	0	0	0
24	D	4	0	0	0	0
25	D	144	0	213	21	0
25	L	49	0	74	4	0
26	E	43	0	30	5	0
27	I	10	0	10	0	0
27	M	10	0	10	0	0
27	T	10	0	10	0	0
28	A	54	0	0	2	0
28	B	62	0	0	7	0
28	C	30	0	0	1	0
28	D	46	0	0	2	0
28	E	2	0	0	0	0
28	L	1	0	0	0	0
28	T	2	0	0	0	0
28	X	1	0	0	0	0
All	All	18884	0	18930	467	0

The all-atom clashscore is defined as the number of clashes found per 1000 atoms (including hydrogen atoms). The all-atom clashscore for this structure is 12.

The worst 5 of 467 close contacts within the same asymmetric unit are listed below, sorted by their clash magnitude.

Atom-1	Atom-2	Interatomic distance (Å)	Clash overlap (Å)
4:D:186:GLN:HB2	15:D:405:CLA:HBC1	1.60	0.83
4:D:259:ILE:HD13	25:D:410:LHG:H261	1.61	0.83
3:C:152:LEU:HD21	15:C:507:CLA:HAB	1.60	0.81
4:D:192:THR:HG23	15:D:405:CLA:HBC2	1.64	0.78
1:A:140:ARG:NH2	25:D:411:LHG:O5	2.17	0.77

There are no symmetry-related clashes.

5.3 Torsion angles [i](#)

5.3.1 Protein backbone [i](#)

In the following table, the Percentiles column shows the percent Ramachandran outliers of the chain as a percentile score with respect to all PDB entries followed by that with respect to all EM entries.

The Analysed column shows the number of residues for which the backbone conformation was analysed, and the total number of residues.

Mol	Chain	Analysed	Favoured	Allowed	Outliers	Percentiles	
1	A	298/360 (83%)	293 (98%)	4 (1%)	1 (0%)	41	62
2	B	476/507 (94%)	469 (98%)	7 (2%)	0	100	100
3	C	409/460 (89%)	399 (98%)	10 (2%)	0	100	100
4	D	340/352 (97%)	333 (98%)	7 (2%)	0	100	100
5	E	70/81 (86%)	67 (96%)	3 (4%)	0	100	100
6	F	30/44 (68%)	30 (100%)	0	0	100	100
7	H	61/64 (95%)	58 (95%)	3 (5%)	0	100	100
8	I	33/38 (87%)	33 (100%)	0	0	100	100
9	K	33/45 (73%)	33 (100%)	0	0	100	100
10	L	29/39 (74%)	29 (100%)	0	0	100	100
11	M	27/35 (77%)	25 (93%)	2 (7%)	0	100	100
12	T	27/31 (87%)	26 (96%)	1 (4%)	0	100	100
13	X	33/39 (85%)	30 (91%)	3 (9%)	0	100	100
All	All	1866/2095 (89%)	1825 (98%)	40 (2%)	1 (0%)	54	73

All (1) Ramachandran outliers are listed below:

Mol	Chain	Res	Type
1	A	260	PHE

5.3.2 Protein sidechains [i](#)

In the following table, the Percentiles column shows the percent sidechain outliers of the chain as a percentile score with respect to all PDB entries followed by that with respect to all EM entries.

The Analysed column shows the number of residues for which the sidechain conformation was analysed, and the total number of residues.

Mol	Chain	Analysed	Rotameric	Outliers	Percentiles	
1	A	245/293 (84%)	245 (100%)	0	100	100
2	B	382/404 (95%)	382 (100%)	0	100	100
3	C	326/361 (90%)	326 (100%)	0	100	100
4	D	278/285 (98%)	277 (100%)	1 (0%)	91	97
5	E	66/73 (90%)	66 (100%)	0	100	100
6	F	26/37 (70%)	26 (100%)	0	100	100
7	H	53/54 (98%)	53 (100%)	0	100	100
8	I	31/34 (91%)	31 (100%)	0	100	100
9	K	29/38 (76%)	29 (100%)	0	100	100
10	L	28/36 (78%)	28 (100%)	0	100	100
11	M	26/32 (81%)	26 (100%)	0	100	100
12	T	24/26 (92%)	23 (96%)	1 (4%)	30	53
13	X	29/33 (88%)	29 (100%)	0	100	100
All	All	1543/1706 (90%)	1541 (100%)	2 (0%)	93	98

All (2) residues with a non-rotameric sidechain are listed below:

Mol	Chain	Res	Type
4	D	180	ARG
12	T	28	ARG

Sometimes sidechains can be flipped to improve hydrogen bonding and reduce clashes. 5 of 13 such sidechains are listed below:

Mol	Chain	Res	Type
2	B	331	ASN
2	B	343	HIS
4	D	142	ASN
3	C	372	GLN
3	C	385	HIS

5.3.3 RNA [i](#)

There are no RNA molecules in this entry.

5.4 Non-standard residues in protein, DNA, RNA chains [i](#)

There are no non-standard protein/DNA/RNA residues in this entry.

5.5 Carbohydrates [i](#)

There are no monosaccharides in this entry.

5.6 Ligand geometry [i](#)

Of 73 ligands modelled in this entry, 2 are monoatomic - leaving 71 for Mogul analysis.

In the following table, the Counts columns list the number of bonds (or angles) for which Mogul statistics could be retrieved, the number of bonds (or angles) that are observed in the model and the number of bonds (or angles) that are defined in the Chemical Component Dictionary. The Link column lists molecule types, if any, to which the group is linked. The Z score for a bond length (or angle) is the number of standard deviations the observed value is removed from the expected value. A bond length (or angle) with $|Z| > 2$ is considered an outlier worth inspection. RMSZ is the root-mean-square of all Z scores of the bond lengths (or angles).

Mol	Type	Chain	Res	Link	Bond lengths			Bond angles		
					Counts	RMSZ	# Z > 2	Counts	RMSZ	# Z > 2
16	PHO	D	403	-	51,69,69	0.98	3 (5%)	47,99,99	1.22	5 (10%)
20	LMG	D	412	-	51,51,55	1.33	8 (15%)	59,59,63	1.06	3 (5%)
15	CLA	C	512	3	45,53,73	2.58	18 (40%)	52,89,113	2.93	19 (36%)
25	LHG	D	410	-	48,48,48	0.92	2 (4%)	51,54,54	1.08	4 (7%)
17	BCR	B	619	-	41,41,41	2.81	6 (14%)	56,56,56	6.47	20 (35%)
15	CLA	C	502	-	65,73,73	2.25	20 (30%)	76,113,113	2.51	24 (31%)
15	CLA	B	607	28	65,73,73	2.23	19 (29%)	76,113,113	2.52	25 (32%)
17	BCR	C	516	-	41,41,41	2.85	6 (14%)	56,56,56	6.48	21 (37%)
25	LHG	D	411	-	45,45,48	0.96	2 (4%)	48,51,54	1.02	2 (4%)
17	BCR	A	406	-	41,41,41	2.83	7 (17%)	56,56,56	6.45	20 (35%)
15	CLA	A	403	-	55,63,73	2.45	20 (36%)	64,101,113	2.75	24 (37%)
15	CLA	B	605	-	65,73,73	2.24	19 (29%)	76,113,113	2.57	23 (30%)
15	CLA	B	601	28	65,73,73	2.23	19 (29%)	76,113,113	2.67	23 (30%)
15	CLA	B	610	28	65,73,73	2.23	20 (30%)	76,113,113	2.58	23 (30%)
15	CLA	C	513	-	65,73,73	2.24	19 (29%)	76,113,113	2.54	22 (28%)
15	CLA	C	508	28	65,73,73	2.21	19 (29%)	76,113,113	2.65	26 (34%)
15	CLA	D	402	28	65,73,73	2.26	20 (30%)	76,113,113	2.57	27 (35%)
15	CLA	C	506	-	65,73,73	2.25	20 (30%)	76,113,113	2.56	23 (30%)

Mol	Type	Chain	Res	Link	Bond lengths			Bond angles		
					Counts	RMSZ	# Z > 2	Counts	RMSZ	# Z > 2
18	SQD	T	101	-	51,52,54	0.97	5 (9%)	60,63,65	1.55	10 (16%)
27	FME	M	101	-	8,9,10	0.94	0	7,9,11	0.95	0
21	LMT	B	622	-	36,36,36	1.19	6 (16%)	47,47,47	1.10	2 (4%)
20	LMG	B	621	-	51,51,55	1.33	8 (15%)	59,59,63	1.16	4 (6%)
18	SQD	B	620	-	50,51,54	0.98	5 (10%)	59,62,65	1.52	9 (15%)
18	SQD	T	103	-	40,41,54	1.08	3 (7%)	49,52,65	1.73	11 (22%)
27	FME	T	102	-	8,9,10	0.94	0	7,9,11	1.03	1 (14%)
15	CLA	B	602	-	65,73,73	2.25	20 (30%)	76,113,113	2.59	24 (31%)
15	CLA	B	616	-	50,58,73	2.51	19 (38%)	58,95,113	2.87	23 (39%)
25	LHG	D	409	-	48,48,48	0.93	2 (4%)	51,54,54	1.03	2 (3%)
15	CLA	C	503	-	65,73,73	2.25	19 (29%)	76,113,113	2.54	21 (27%)
15	CLA	B	606	-	60,68,73	2.34	20 (33%)	70,107,113	2.58	25 (35%)
18	SQD	X	101	-	41,42,54	1.11	5 (12%)	50,53,65	1.82	12 (24%)
15	CLA	D	406	-	65,73,73	2.25	19 (29%)	76,113,113	2.64	23 (30%)
15	CLA	D	405	-	65,73,73	2.23	19 (29%)	76,113,113	2.59	22 (28%)
15	CLA	A	405	-	50,58,73	2.58	20 (40%)	58,95,113	2.98	24 (41%)
27	FME	I	101	-	8,9,10	0.94	0	7,9,11	1.03	0
15	CLA	A	402	-	65,73,73	2.22	19 (29%)	76,113,113	2.57	25 (32%)
17	BCR	B	618	-	41,41,41	2.85	6 (14%)	56,56,56	6.44	20 (35%)
15	CLA	C	514	-	65,73,73	2.26	20 (30%)	76,113,113	2.53	24 (31%)
15	CLA	B	609	-	65,73,73	2.23	19 (29%)	76,113,113	2.57	21 (27%)
18	SQD	A	409	-	53,54,54	0.97	5 (9%)	62,65,65	1.49	9 (14%)
15	CLA	B	604	-	65,73,73	2.25	20 (30%)	76,113,113	2.57	24 (31%)
15	CLA	C	511	-	65,73,73	2.25	19 (29%)	76,113,113	2.63	24 (31%)
21	LMT	B	623	-	35,35,36	1.20	6 (17%)	46,46,47	1.08	3 (6%)
15	CLA	B	613	-	65,73,73	2.24	19 (29%)	76,113,113	2.60	22 (28%)
17	BCR	X	102	-	41,41,41	2.84	6 (14%)	56,56,56	6.55	21 (37%)
17	BCR	D	407	-	41,41,41	2.82	6 (14%)	56,56,56	6.66	21 (37%)
15	CLA	B	611	-	65,73,73	2.23	19 (29%)	76,113,113	2.51	22 (28%)
15	CLA	C	509	-	55,63,73	2.43	20 (36%)	64,101,113	2.79	25 (39%)
17	BCR	C	515	-	41,41,41	2.82	7 (17%)	56,56,56	6.37	22 (39%)
15	CLA	B	614	-	55,63,73	2.42	20 (36%)	64,101,113	2.76	24 (37%)
20	LMG	C	501	-	51,51,55	1.35	8 (15%)	59,59,63	1.09	3 (5%)
18	SQD	A	407	-	47,48,54	1.00	4 (8%)	56,59,65	1.76	11 (19%)
26	HEM	E	101	6,5	41,50,50	1.53	4 (9%)	45,82,82	1.32	6 (13%)

Mol	Type	Chain	Res	Link	Bond lengths			Bond angles		
					Counts	RMSZ	# Z > 2	Counts	RMSZ	# Z > 2
16	PHO	A	404	-	51,69,69	1.01	4 (7%)	47,99,99	1.20	5 (10%)
19	PL9	A	408	-	15,15,55	1.47	4 (26%)	20,21,69	1.79	4 (20%)
17	BCR	B	617	-	41,41,41	2.83	6 (14%)	56,56,56	6.47	21 (37%)
22	DGD	C	517	-	63,63,67	1.23	7 (11%)	77,77,81	0.96	3 (3%)
15	CLA	B	612	-	65,73,73	2.22	18 (27%)	76,113,113	2.51	21 (27%)
15	CLA	B	615	-	65,73,73	2.25	20 (30%)	76,113,113	2.55	24 (31%)
15	CLA	C	505	28	65,73,73	2.24	20 (30%)	76,113,113	2.61	26 (34%)
15	CLA	C	510	-	65,73,73	2.23	19 (29%)	76,113,113	2.52	22 (28%)
17	BCR	C	519	-	41,41,41	2.85	6 (14%)	56,56,56	6.42	21 (37%)
24	BCT	D	404	14	2,3,3	1.30	0	2,3,3	2.57	1 (50%)
25	LHG	L	101	-	48,48,48	0.92	2 (4%)	51,54,54	1.05	3 (5%)
22	DGD	H	101	-	63,63,67	1.23	8 (12%)	77,77,81	0.99	2 (2%)
15	CLA	C	507	-	65,73,73	2.24	20 (30%)	76,113,113	2.58	25 (32%)
19	PL9	D	408	-	55,55,55	1.26	5 (9%)	68,69,69	1.51	12 (17%)
15	CLA	B	603	-	65,73,73	2.25	19 (29%)	76,113,113	2.57	25 (32%)
18	SQD	C	518	-	53,54,54	0.97	4 (7%)	62,65,65	1.54	9 (14%)
15	CLA	C	504	-	65,73,73	2.24	19 (29%)	76,113,113	2.61	24 (31%)
15	CLA	B	608	-	65,73,73	2.23	19 (29%)	76,113,113	2.52	22 (28%)

In the following table, the Chirals column lists the number of chiral outliers, the number of chiral centers analysed, the number of these observed in the model and the number defined in the Chemical Component Dictionary. Similar counts are reported in the Torsion and Rings columns. '-' means no outliers of that kind were identified.

Mol	Type	Chain	Res	Link	Chirals	Torsions	Rings
16	PHO	D	403	-	-	8/37/103/103	0/5/6/6
20	LMG	D	412	-	-	16/46/66/70	0/1/1/1
15	CLA	C	512	3	1/1/11/20	6/13/91/115	-
25	LHG	D	410	-	-	25/53/53/53	-
17	BCR	B	619	-	-	9/29/63/63	0/2/2/2
15	CLA	C	502	-	1/1/15/20	10/37/115/115	-
15	CLA	B	607	28	1/1/15/20	16/37/115/115	-
17	BCR	C	516	-	-	2/29/63/63	0/2/2/2
25	LHG	D	411	-	-	29/50/50/53	-
17	BCR	A	406	-	-	7/29/63/63	0/2/2/2
15	CLA	A	403	-	1/1/13/20	10/25/103/115	-

Continued on next page...

Continued from previous page...

Mol	Type	Chain	Res	Link	Chirals	Torsions	Rings
15	CLA	B	605	-	1/1/15/20	14/37/115/115	-
15	CLA	B	601	28	1/1/15/20	18/37/115/115	-
15	CLA	B	610	28	1/1/15/20	5/37/115/115	-
15	CLA	C	513	-	1/1/15/20	18/37/115/115	-
15	CLA	C	508	28	1/1/15/20	15/37/115/115	-
15	CLA	D	402	28	1/1/15/20	9/37/115/115	-
15	CLA	C	506	-	1/1/15/20	11/37/115/115	-
18	SQD	T	101	-	-	25/47/67/69	0/1/1/1
27	FME	M	101	-	-	3/7/9/11	-
21	LMT	B	622	-	-	7/21/61/61	0/2/2/2
20	LMG	B	621	-	-	9/46/66/70	0/1/1/1
18	SQD	B	620	-	-	21/46/66/69	0/1/1/1
18	SQD	T	103	-	-	14/36/56/69	0/1/1/1
27	FME	T	102	-	-	4/7/9/11	-
15	CLA	B	602	-	1/1/15/20	22/37/115/115	-
15	CLA	B	616	-	1/1/12/20	9/19/97/115	-
25	LHG	D	409	-	-	27/53/53/53	-
15	CLA	C	503	-	1/1/15/20	14/37/115/115	-
15	CLA	B	606	-	1/1/14/20	12/31/109/115	-
18	SQD	X	101	-	-	20/37/57/69	0/1/1/1
15	CLA	D	406	-	1/1/15/20	11/37/115/115	-
15	CLA	D	405	-	1/1/15/20	15/37/115/115	-
15	CLA	A	405	-	1/1/12/20	6/19/97/115	-
27	FME	I	101	-	-	2/7/9/11	-
15	CLA	A	402	-	1/1/15/20	9/37/115/115	-
17	BCR	B	618	-	-	9/29/63/63	0/2/2/2
15	CLA	C	514	-	1/1/15/20	17/37/115/115	-
15	CLA	B	609	-	1/1/15/20	19/37/115/115	-
18	SQD	A	409	-	-	22/49/69/69	0/1/1/1
15	CLA	B	604	-	1/1/15/20	17/37/115/115	-
15	CLA	C	511	-	1/1/15/20	11/37/115/115	-
21	LMT	B	623	-	-	9/20/60/61	0/2/2/2
15	CLA	B	613	-	1/1/15/20	15/37/115/115	-
17	BCR	X	102	-	-	10/29/63/63	0/2/2/2

Continued on next page...

Continued from previous page...

Mol	Type	Chain	Res	Link	Chirals	Torsions	Rings
17	BCR	D	407	-	-	11/29/63/63	0/2/2/2
15	CLA	B	611	-	1/1/15/20	16/37/115/115	-
15	CLA	C	509	-	1/1/13/20	14/25/103/115	-
17	BCR	C	515	-	-	13/29/63/63	0/2/2/2
15	CLA	B	614	-	1/1/13/20	10/25/103/115	-
20	LMG	C	501	-	-	15/46/66/70	0/1/1/1
18	SQD	A	407	-	-	15/43/63/69	0/1/1/1
26	HEM	E	101	6,5	-	2/12/54/54	-
16	PHO	A	404	-	-	12/37/103/103	0/5/6/6
19	PL9	A	408	-	-	1/5/25/73	0/1/1/1
17	BCR	B	617	-	-	10/29/63/63	0/2/2/2
22	DGD	C	517	-	-	9/51/91/95	0/2/2/2
15	CLA	B	612	-	1/1/15/20	16/37/115/115	-
15	CLA	B	615	-	1/1/15/20	8/37/115/115	-
15	CLA	C	505	28	1/1/15/20	13/37/115/115	-
15	CLA	C	510	-	1/1/15/20	19/37/115/115	-
17	BCR	C	519	-	-	9/29/63/63	0/2/2/2
25	LHG	L	101	-	-	29/53/53/53	-
22	DGD	H	101	-	-	9/51/91/95	0/2/2/2
15	CLA	C	507	-	1/1/15/20	22/37/115/115	-
19	PL9	D	408	-	-	13/53/73/73	0/1/1/1
15	CLA	B	603	-	1/1/15/20	18/37/115/115	-
18	SQD	C	518	-	-	15/49/69/69	0/1/1/1
15	CLA	C	504	-	1/1/15/20	16/37/115/115	-
15	CLA	B	608	-	1/1/15/20	21/37/115/115	-

The worst 5 of 844 bond length outliers are listed below:

Mol	Chain	Res	Type	Atoms	Z	Observed(Å)	Ideal(Å)
17	C	515	BCR	C8-C9	-8.42	1.27	1.45
17	B	617	BCR	C8-C9	-8.38	1.27	1.45
17	B	618	BCR	C8-C9	-8.35	1.28	1.45
17	C	519	BCR	C11-C10	-8.32	1.17	1.43
17	C	516	BCR	C8-C9	-8.31	1.28	1.45

The worst 5 of 1144 bond angle outliers are listed below:

Mol	Chain	Res	Type	Atoms	Z	Observed(°)	Ideal(°)
17	D	407	BCR	C20-C21-C22	23.19	160.40	127.31
17	C	516	BCR	C20-C21-C22	21.49	157.99	127.31
17	B	617	BCR	C20-C21-C22	21.21	157.57	127.31
17	D	407	BCR	C15-C16-C17	20.88	166.25	123.47
17	C	515	BCR	C20-C21-C22	20.85	157.07	127.31

5 of 35 chirality outliers are listed below:

Mol	Chain	Res	Type	Atom
15	A	402	CLA	ND
15	A	403	CLA	ND
15	A	405	CLA	ND
15	B	601	CLA	ND
15	B	602	CLA	ND

5 of 923 torsion outliers are listed below:

Mol	Chain	Res	Type	Atoms
15	A	403	CLA	CHA-CBD-CGD-O1D
15	A	403	CLA	CHA-CBD-CGD-O2D
15	B	601	CLA	CBA-CGA-O2A-C1
15	B	601	CLA	O1A-CGA-O2A-C1
15	B	601	CLA	CAD-CBD-CGD-O1D

There are no ring outliers.

66 monomers are involved in 267 short contacts:

Mol	Chain	Res	Type	Clashes	Symm-Clashes
16	D	403	PHO	4	0
20	D	412	LMG	2	0
15	C	512	CLA	4	0
25	D	410	LHG	6	0
17	B	619	BCR	2	0
15	C	502	CLA	7	0
15	B	607	CLA	6	0
17	C	516	BCR	5	0
25	D	411	LHG	9	0
17	A	406	BCR	5	0
15	A	403	CLA	2	0
15	B	605	CLA	6	0
15	B	601	CLA	6	0
15	B	610	CLA	6	0
15	C	513	CLA	4	0

Continued on next page...

Continued from previous page...

Mol	Chain	Res	Type	Clashes	Symm-Clashes
15	C	508	CLA	5	0
15	D	402	CLA	6	0
15	C	506	CLA	11	0
18	T	101	SQD	4	0
21	B	622	LMT	3	0
20	B	621	LMG	3	0
18	B	620	SQD	4	0
18	T	103	SQD	2	0
15	B	602	CLA	4	0
15	B	616	CLA	3	0
25	D	409	LHG	6	0
15	C	503	CLA	3	0
15	B	606	CLA	5	0
18	X	101	SQD	4	0
15	D	406	CLA	4	0
15	D	405	CLA	6	0
15	A	405	CLA	3	0
15	A	402	CLA	5	0
17	B	618	BCR	4	0
15	C	514	CLA	2	0
15	B	609	CLA	5	0
18	A	409	SQD	4	0
15	B	604	CLA	5	0
15	C	511	CLA	10	0
21	B	623	LMT	5	0
15	B	613	CLA	9	0
17	X	102	BCR	7	0
17	D	407	BCR	3	0
15	B	611	CLA	5	0
15	C	509	CLA	5	0
17	C	515	BCR	2	0
15	B	614	CLA	5	0
20	C	501	LMG	8	0
18	A	407	SQD	4	0
26	E	101	HEM	5	0
16	A	404	PHO	6	0
19	A	408	PL9	1	0
17	B	617	BCR	5	0
22	C	517	DGD	2	0
15	B	612	CLA	6	0
15	B	615	CLA	7	0
15	C	505	CLA	1	0

Continued on next page...

Continued from previous page...

Mol	Chain	Res	Type	Clashes	Symm-Clashes
15	C	510	CLA	5	0
17	C	519	BCR	6	0
25	L	101	LHG	4	0
22	H	101	DGD	4	0
15	C	507	CLA	9	0
15	B	603	CLA	6	0
18	C	518	SQD	5	0
15	C	504	CLA	7	0
15	B	608	CLA	5	0

The following is a two-dimensional graphical depiction of Mogul quality analysis of bond lengths, bond angles, torsion angles, and ring geometry for all instances of the Ligand of Interest. In addition, ligands with molecular weight > 250 and outliers as shown on the validation Tables will also be included. For torsion angles, if less than 5% of the Mogul distribution of torsion angles is within 10 degrees of the torsion angle in question, then that torsion angle is considered an outlier. Any bond that is central to one or more torsion angles identified as an outlier by Mogul will be highlighted in the graph. For rings, the root-mean-square deviation (RMSD) between the ring in question and similar rings identified by Mogul is calculated over all ring torsion angles. If the average RMSD is greater than 60 degrees and the minimal RMSD between the ring in question and any Mogul-identified rings is also greater than 60 degrees, then that ring is considered an outlier. The outliers are highlighted in purple. The color gray indicates Mogul did not find sufficient equivalents in the CSD to analyse the geometry.

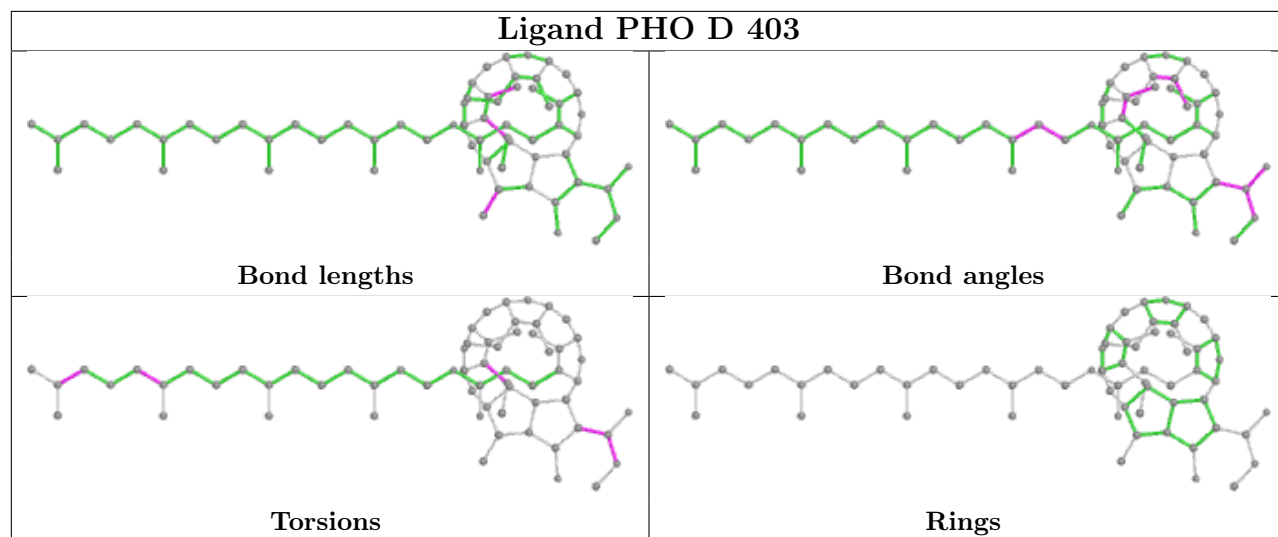

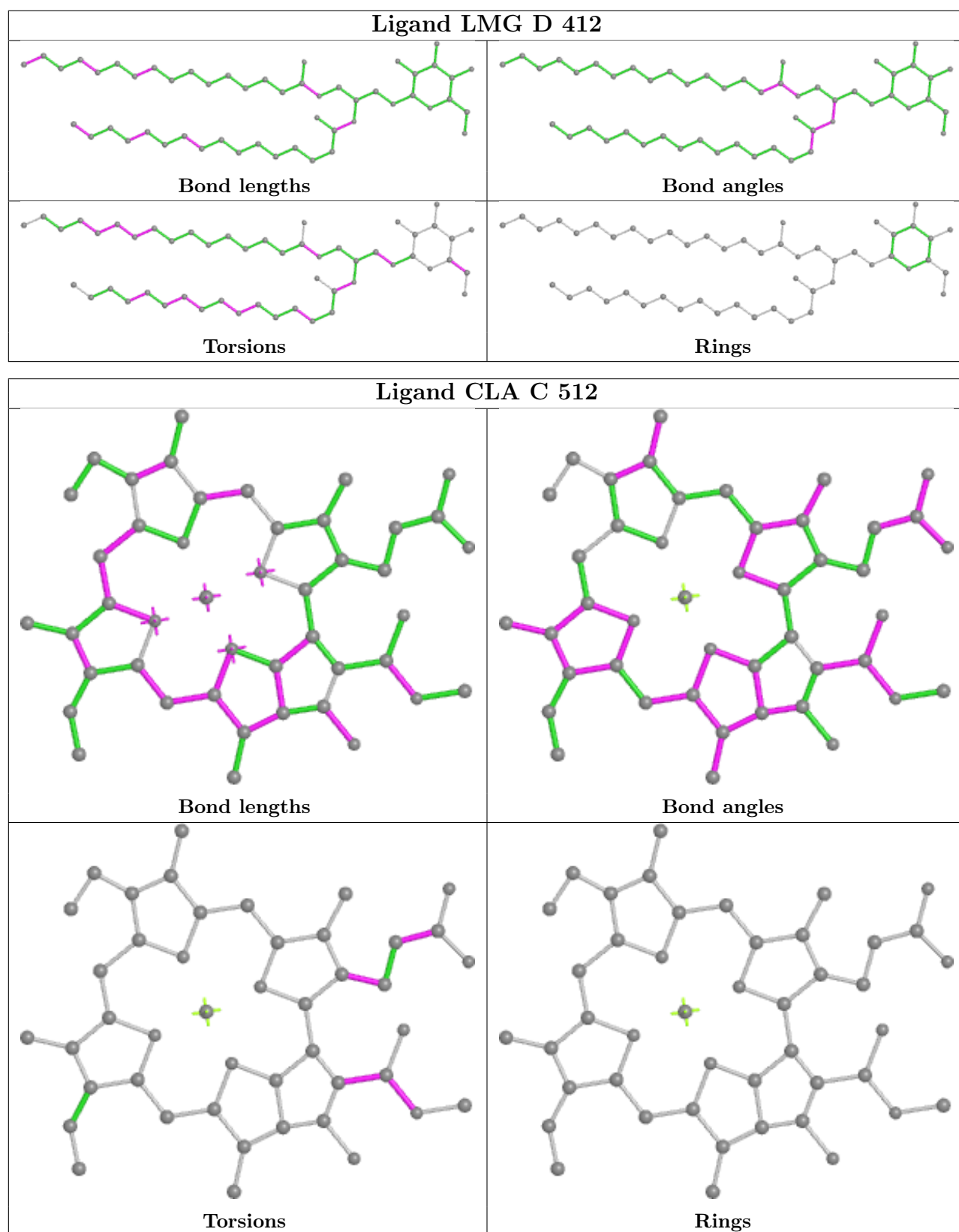

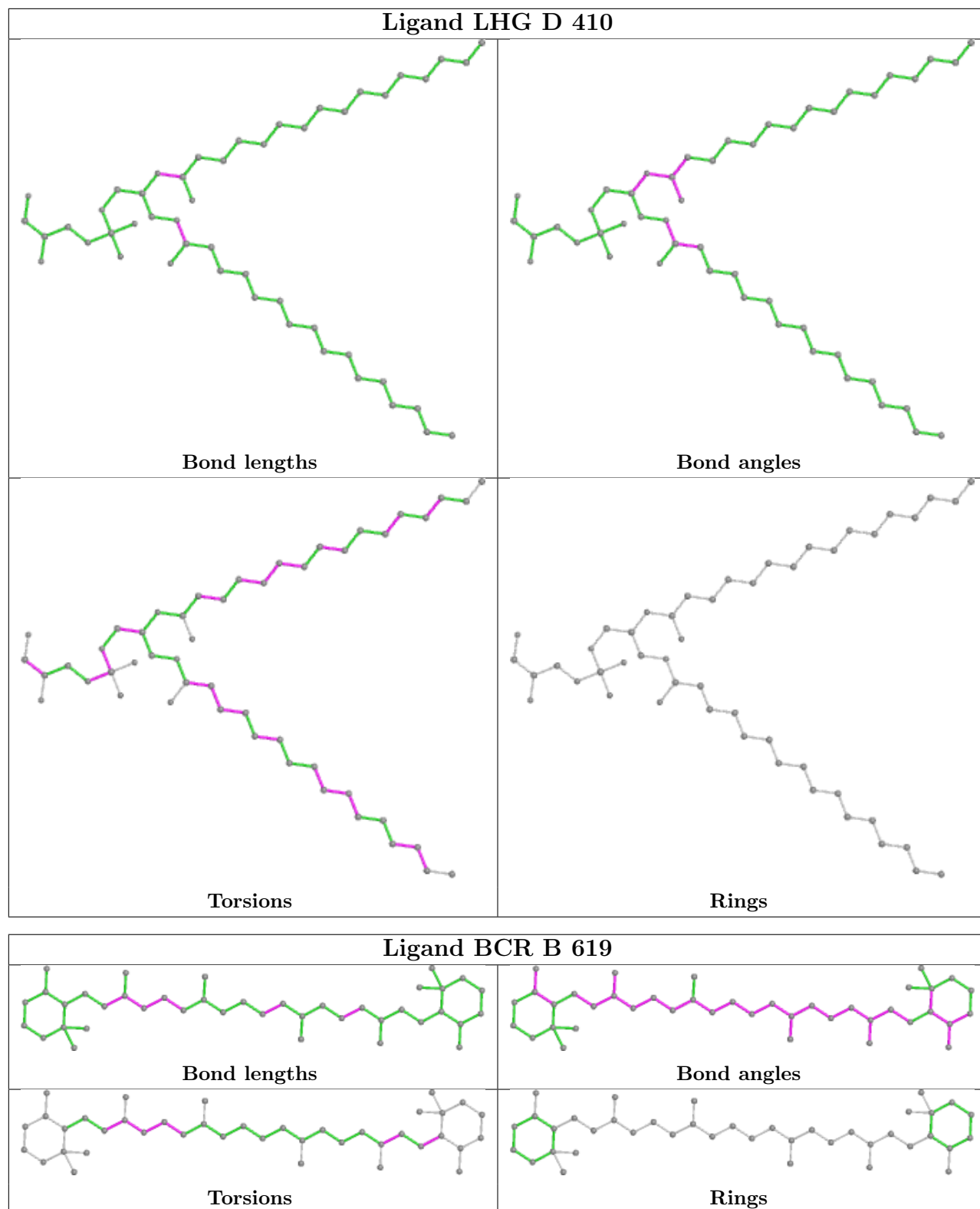

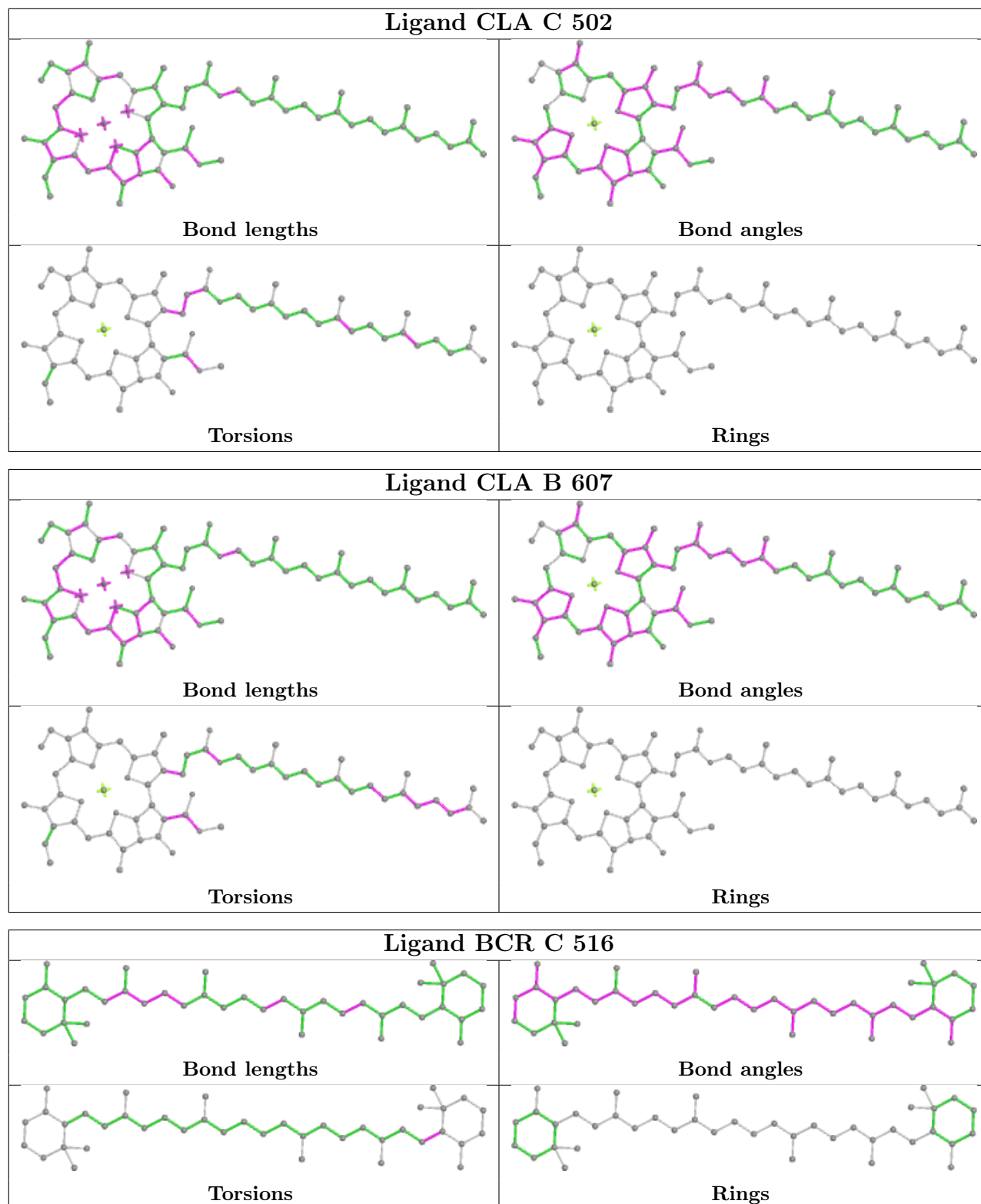

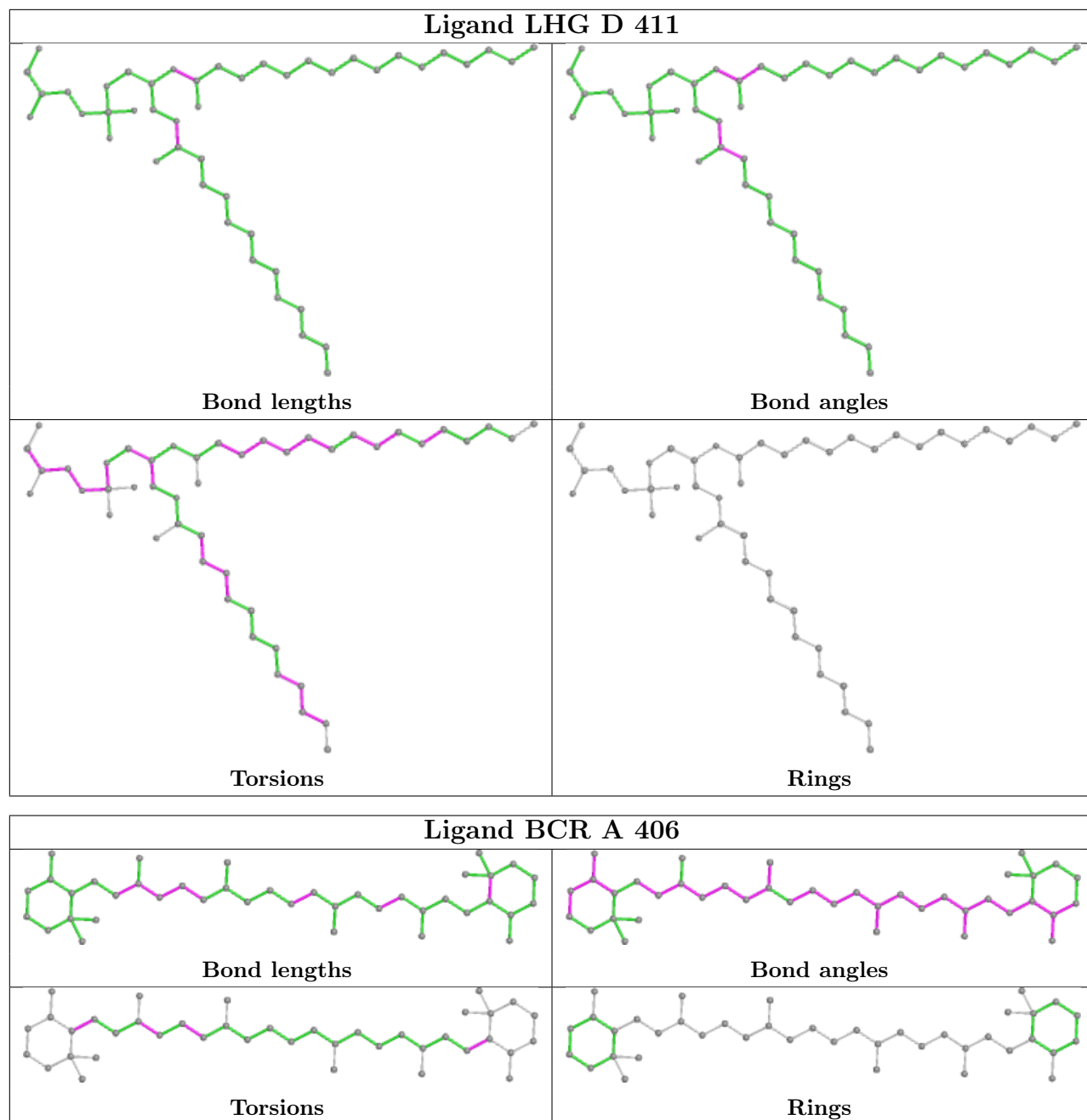

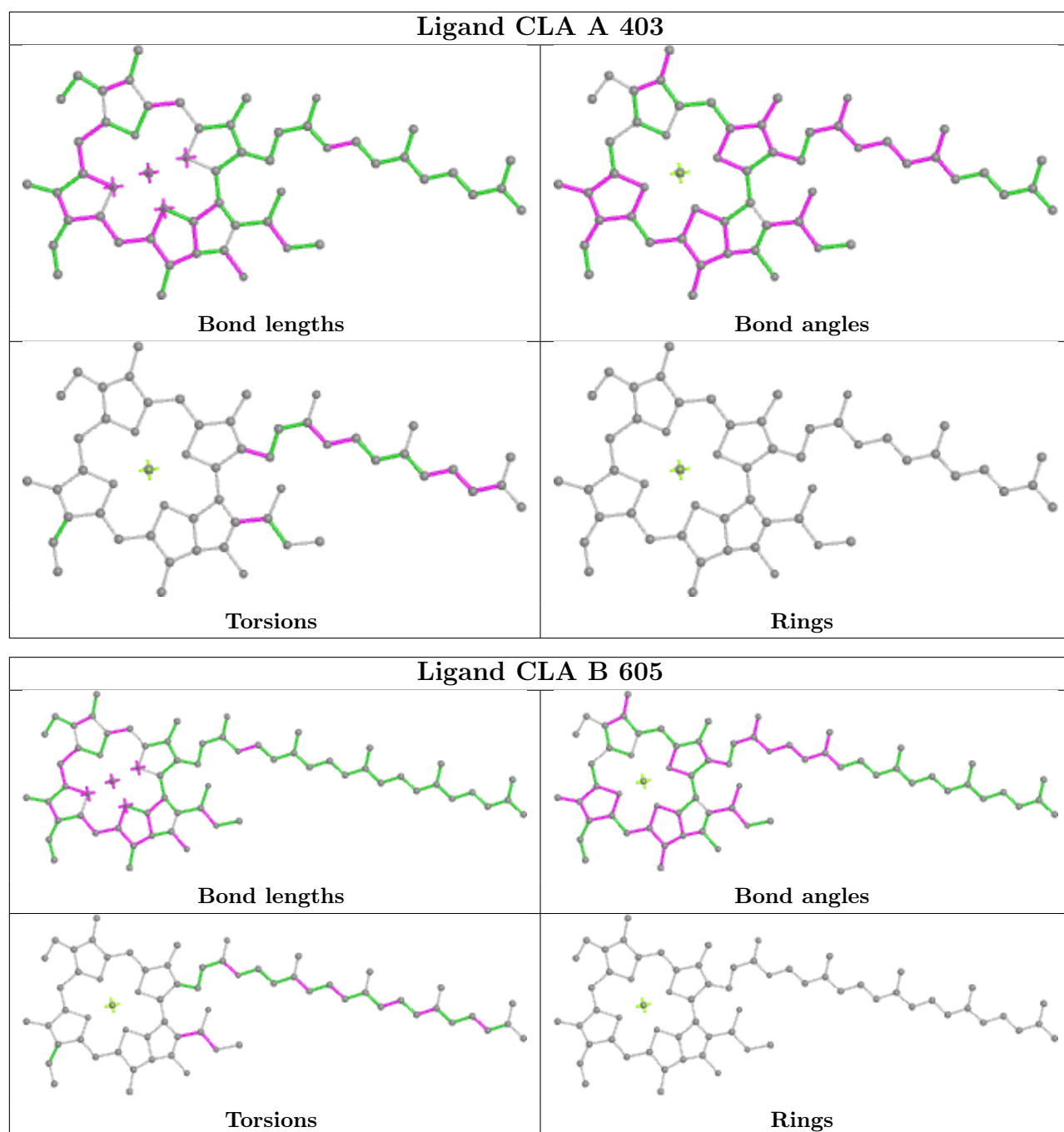

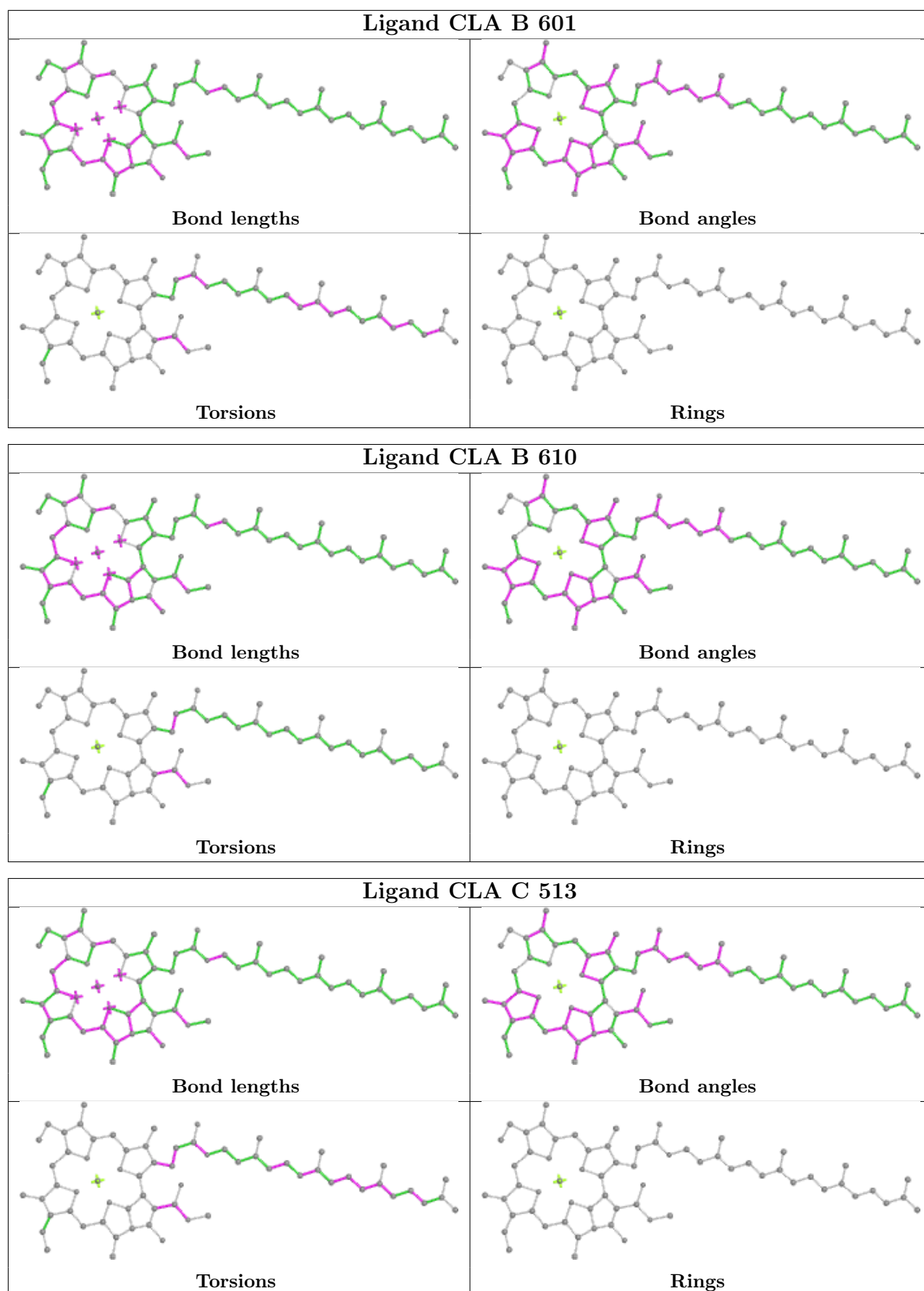

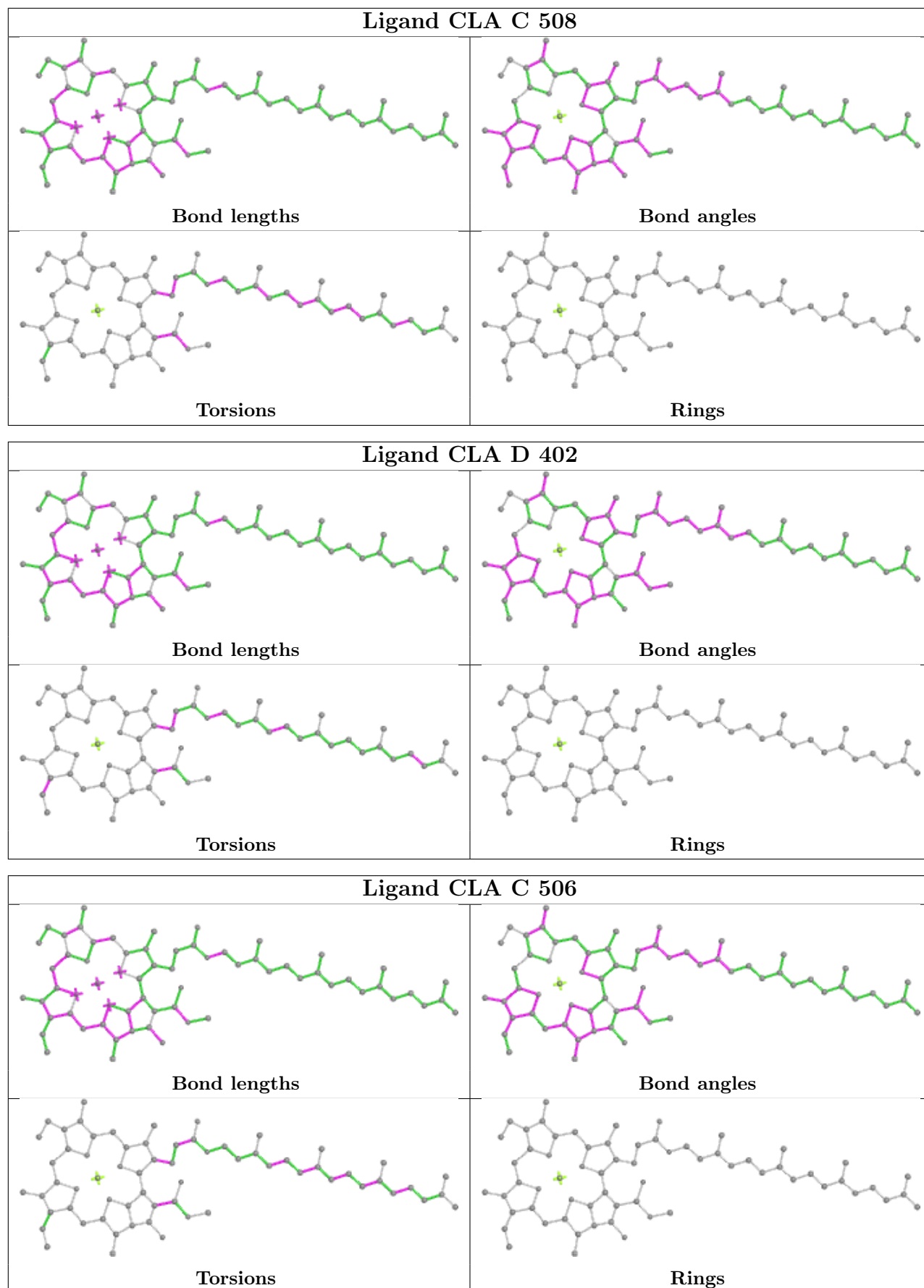

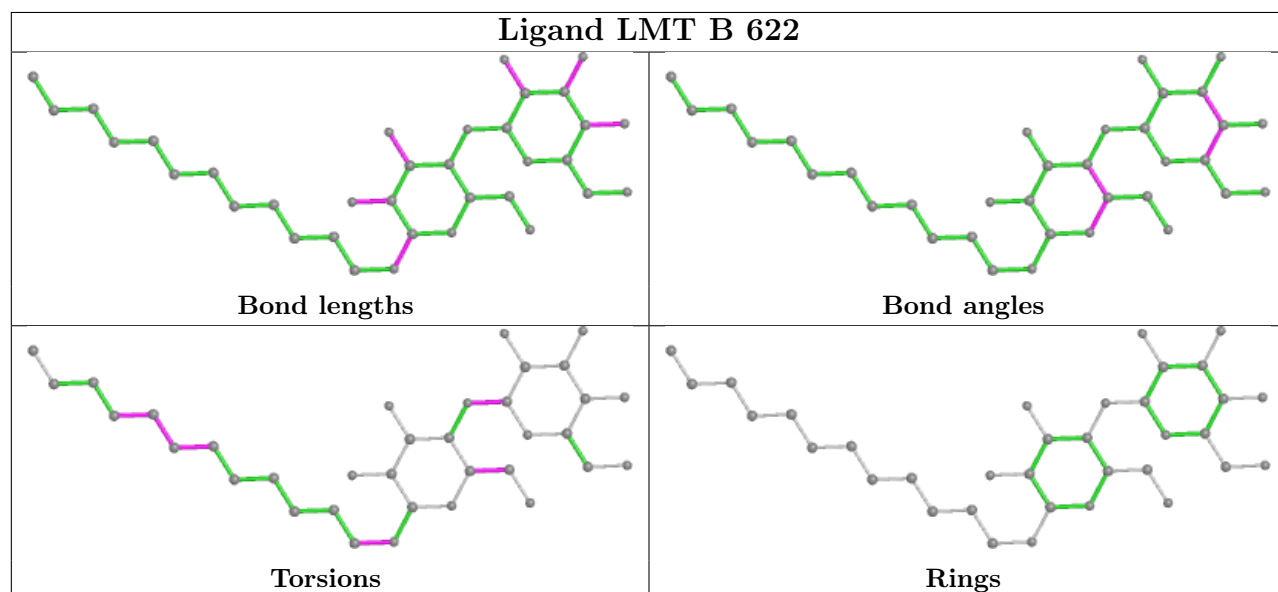
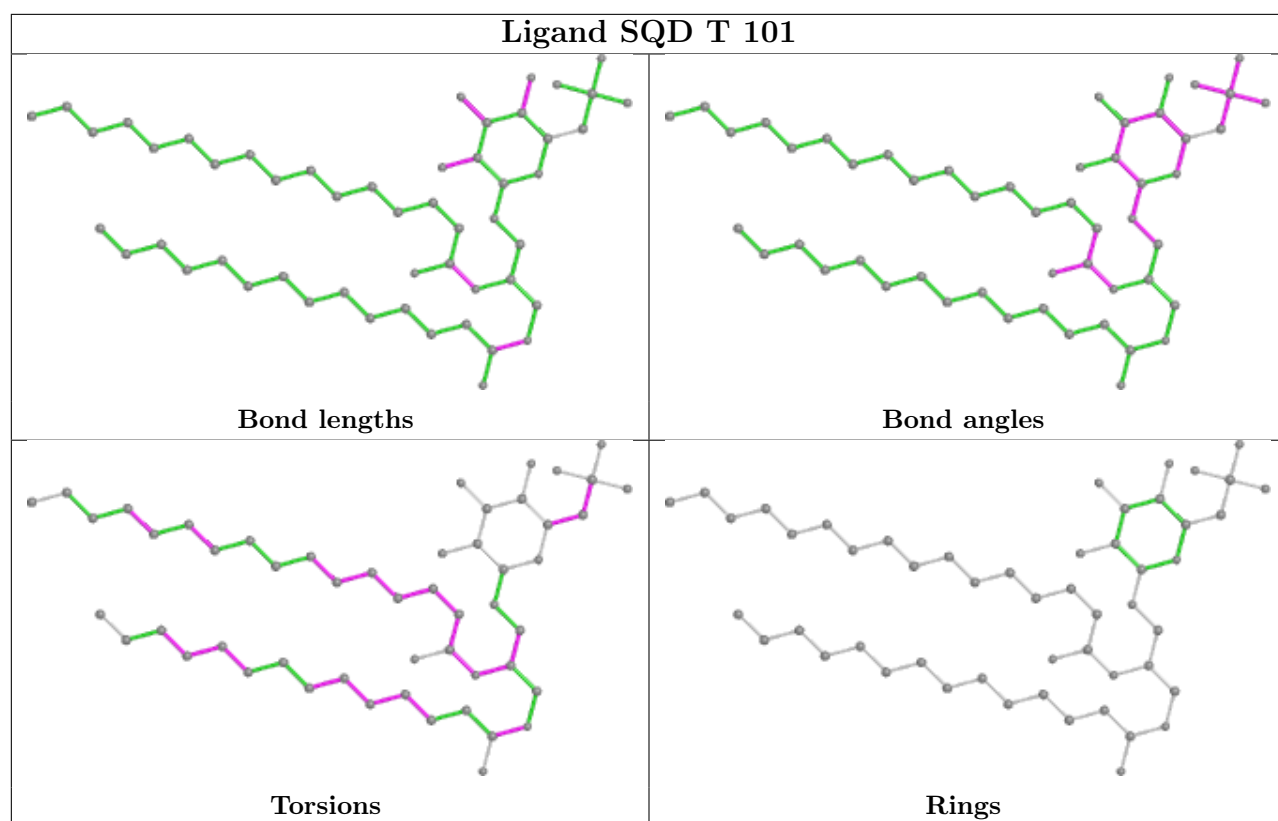

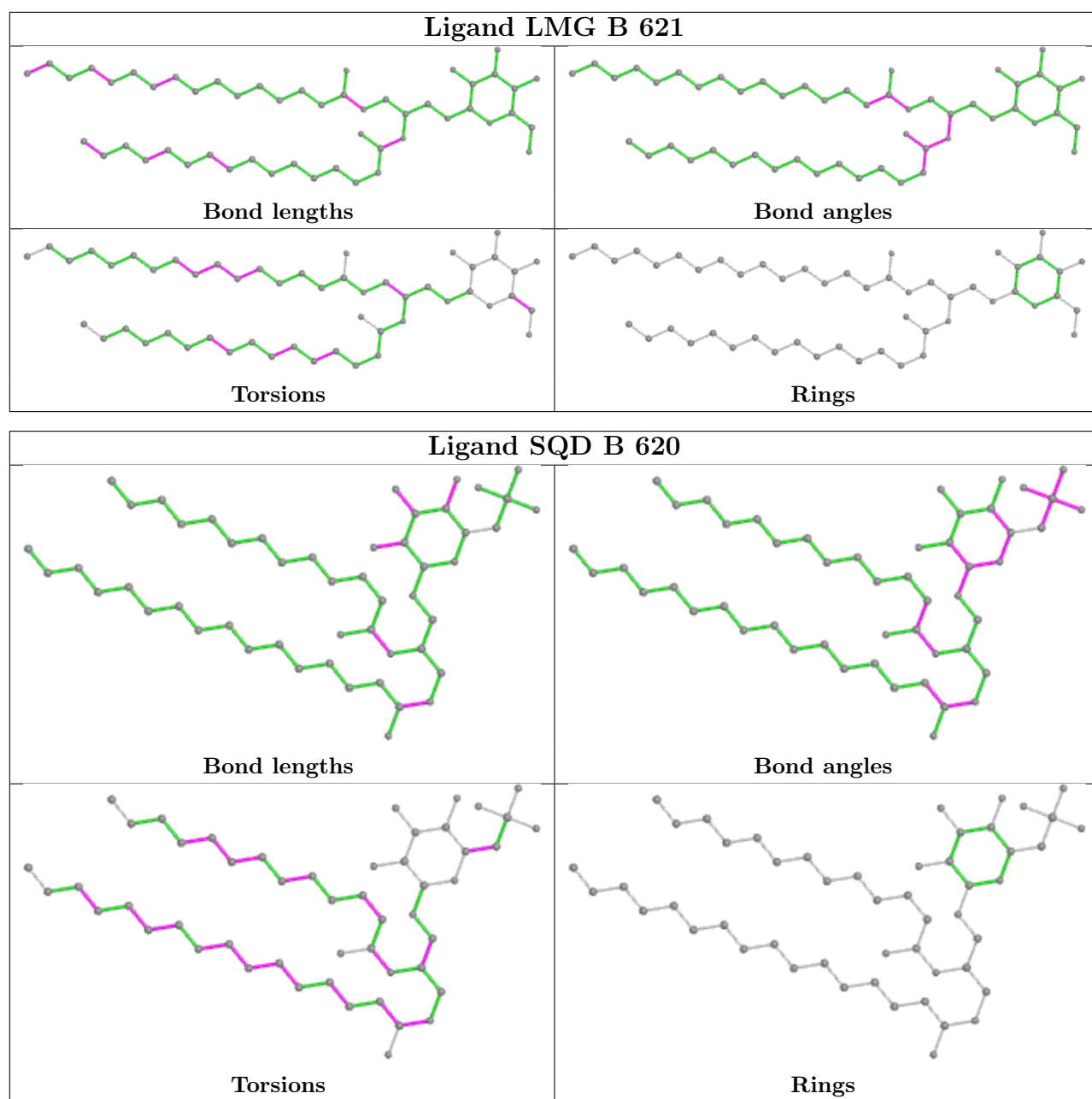

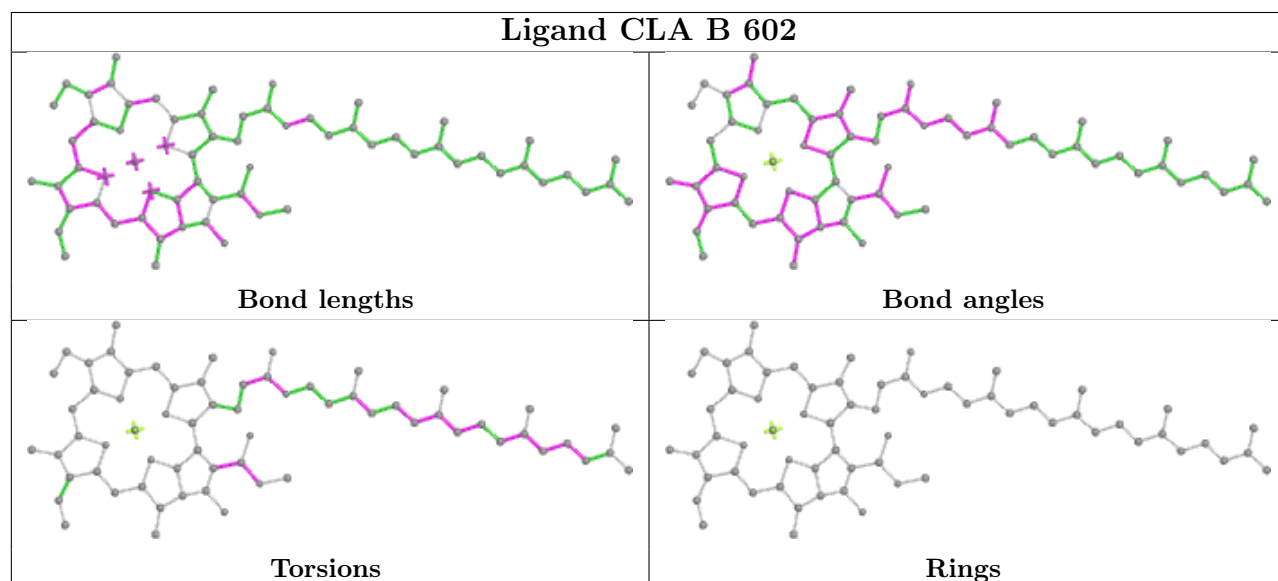
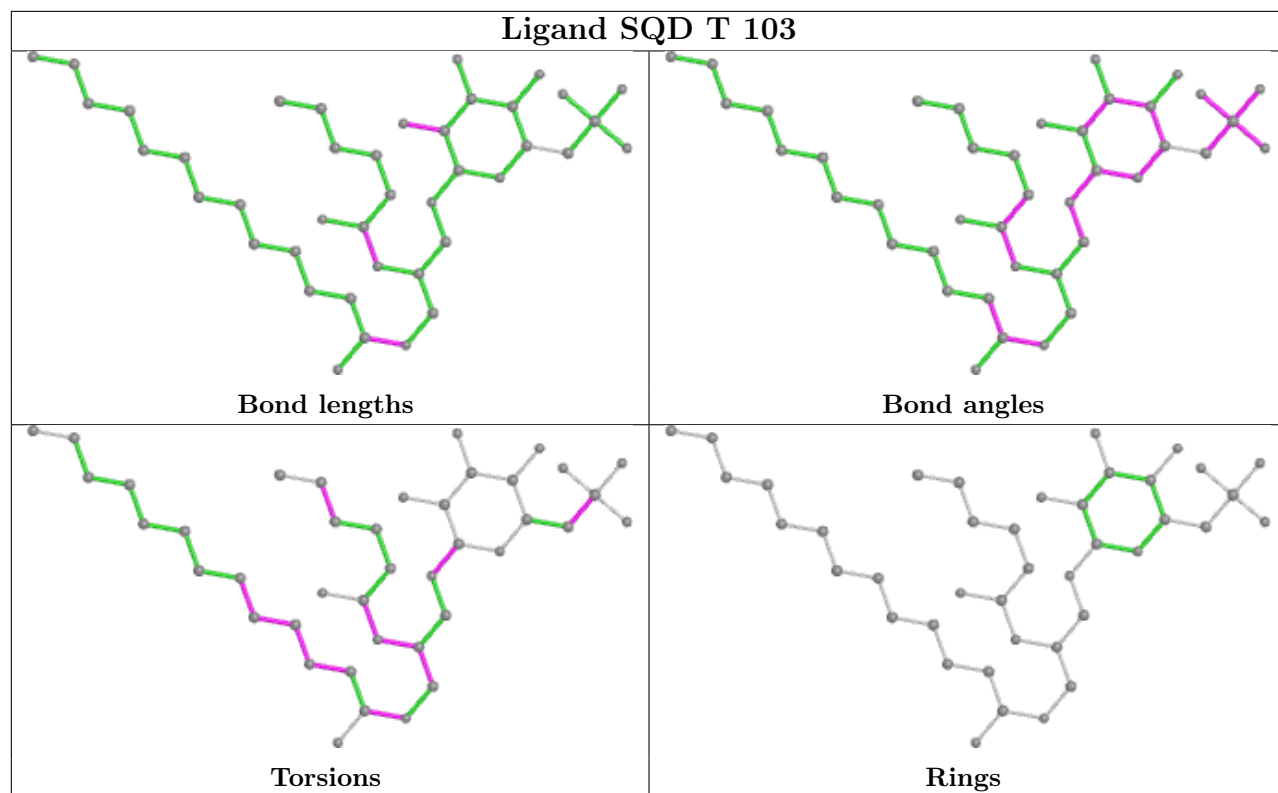

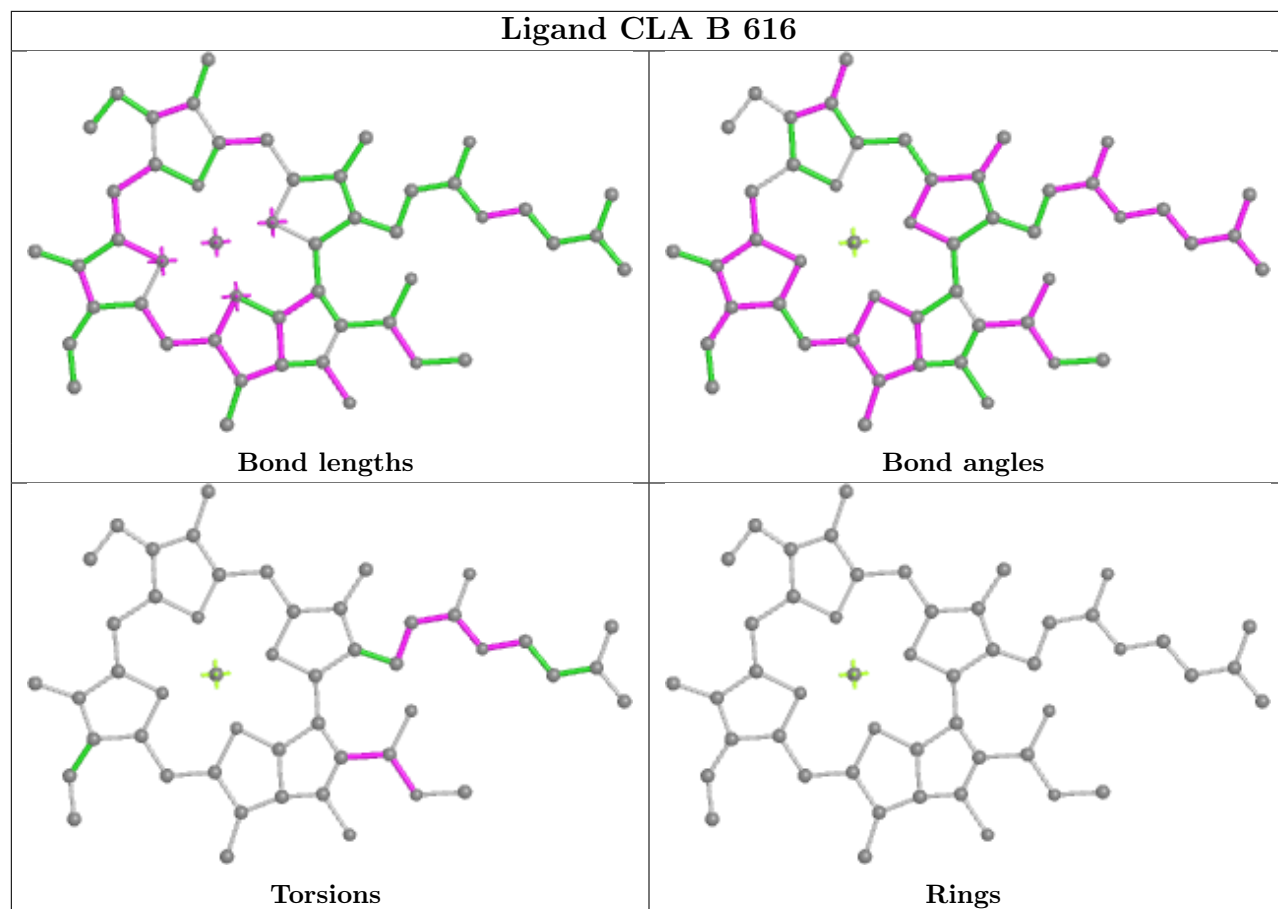

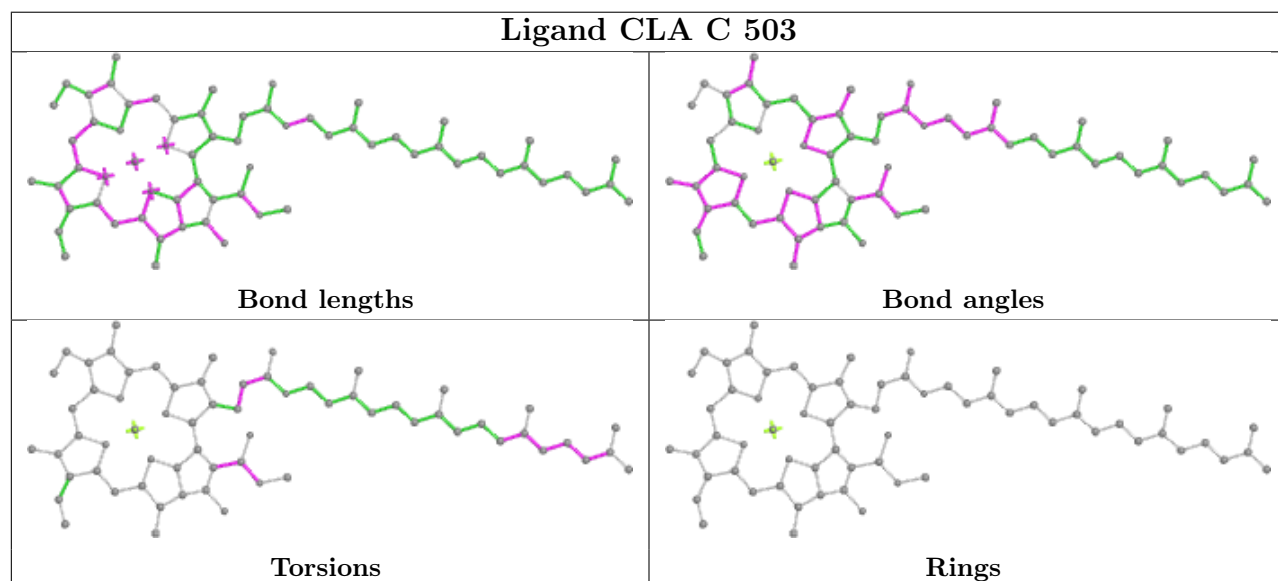
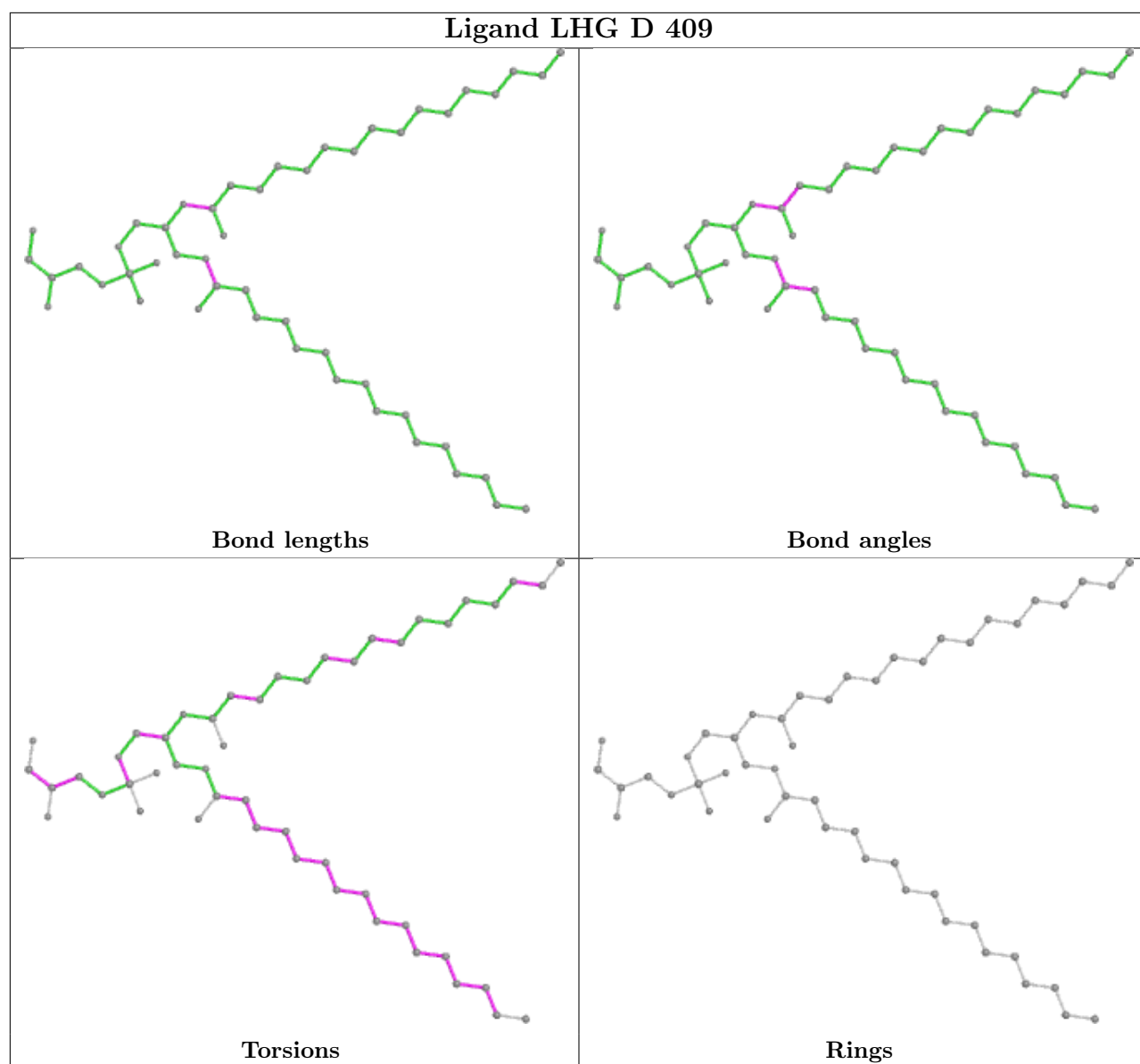

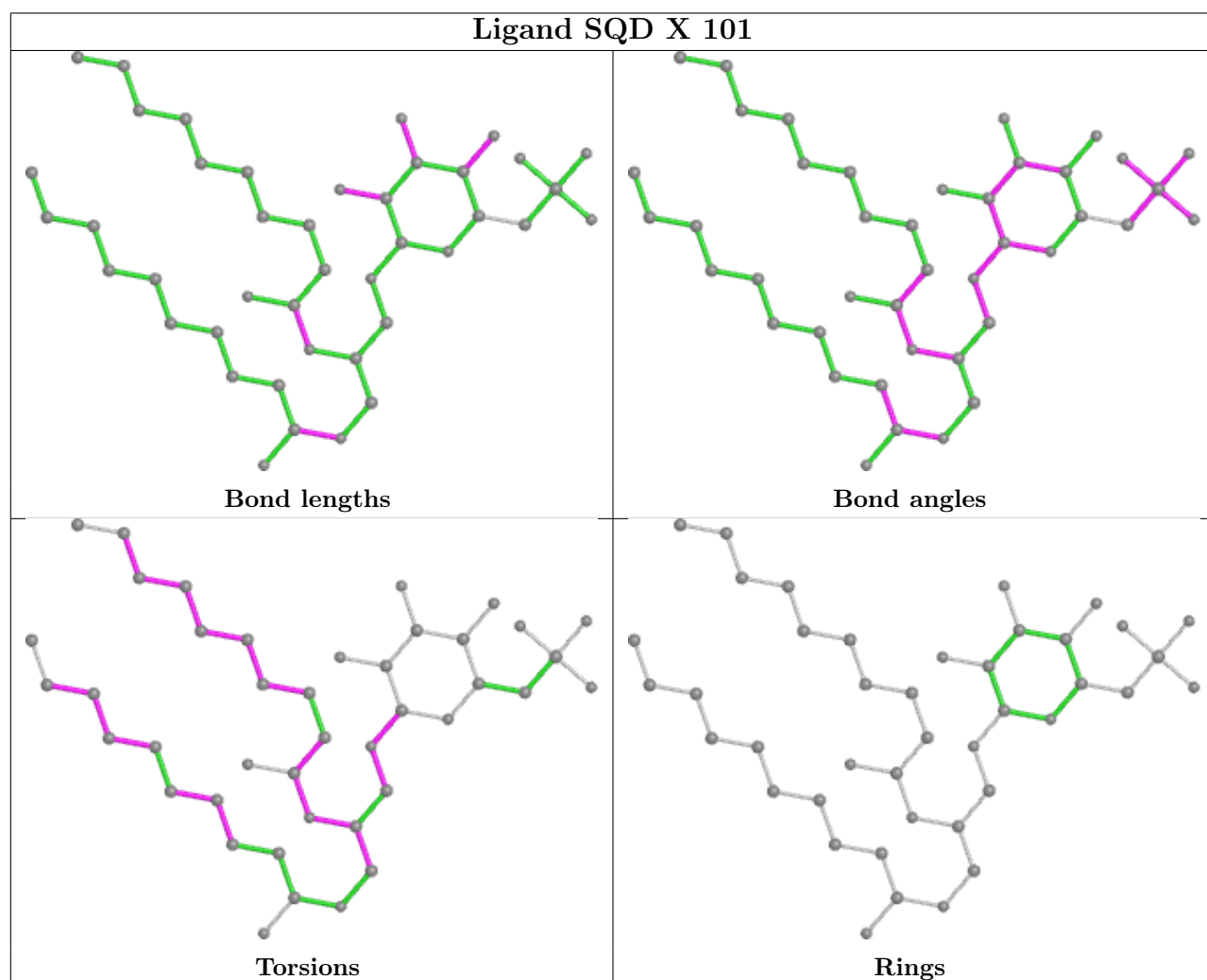
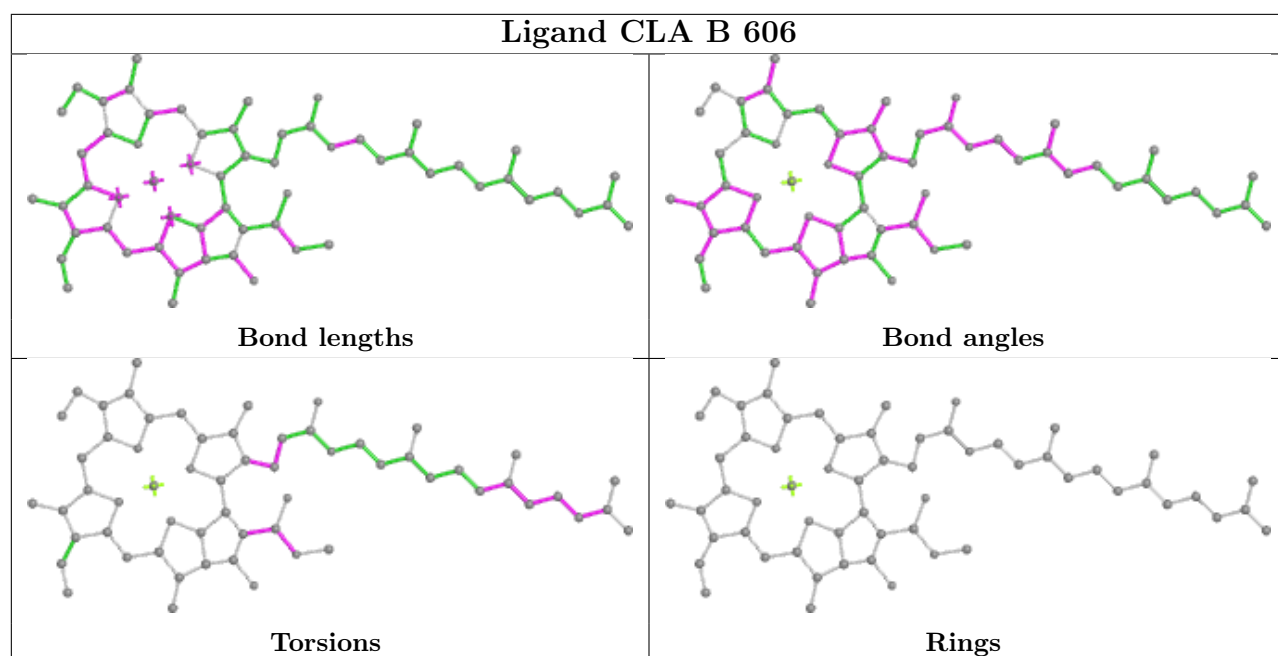

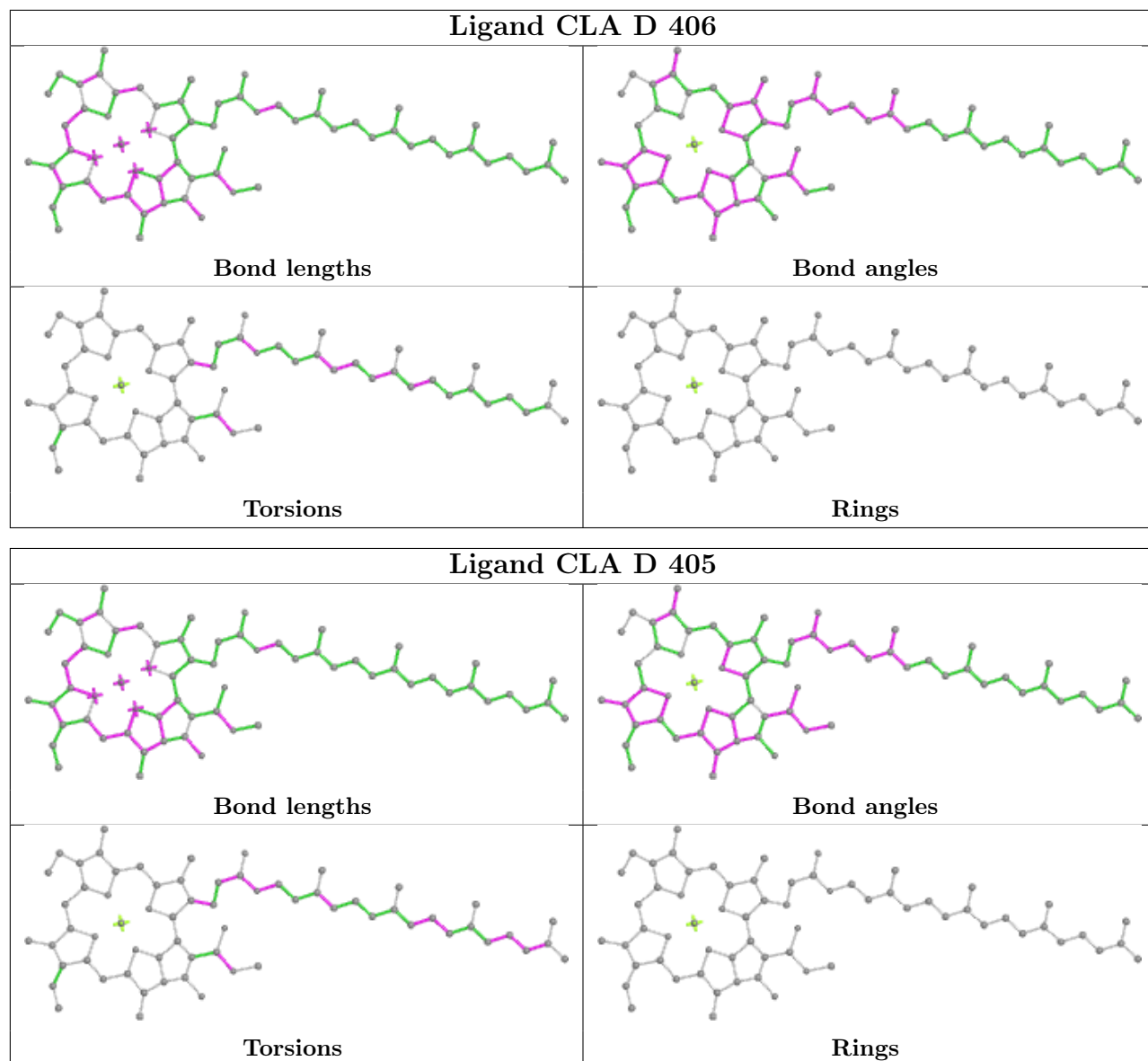

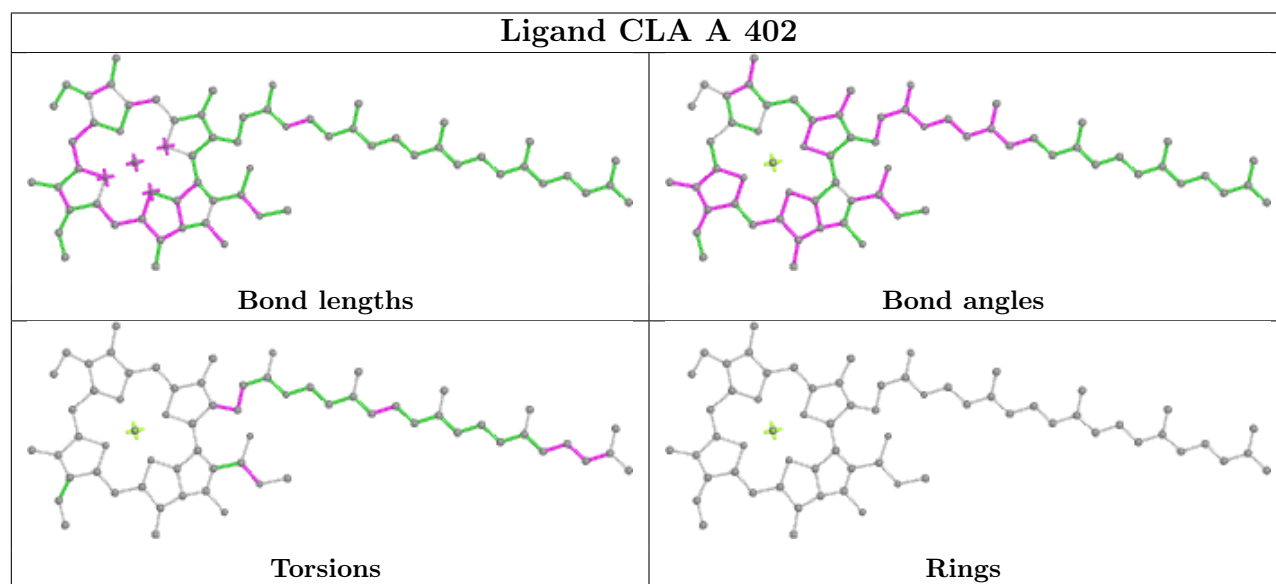
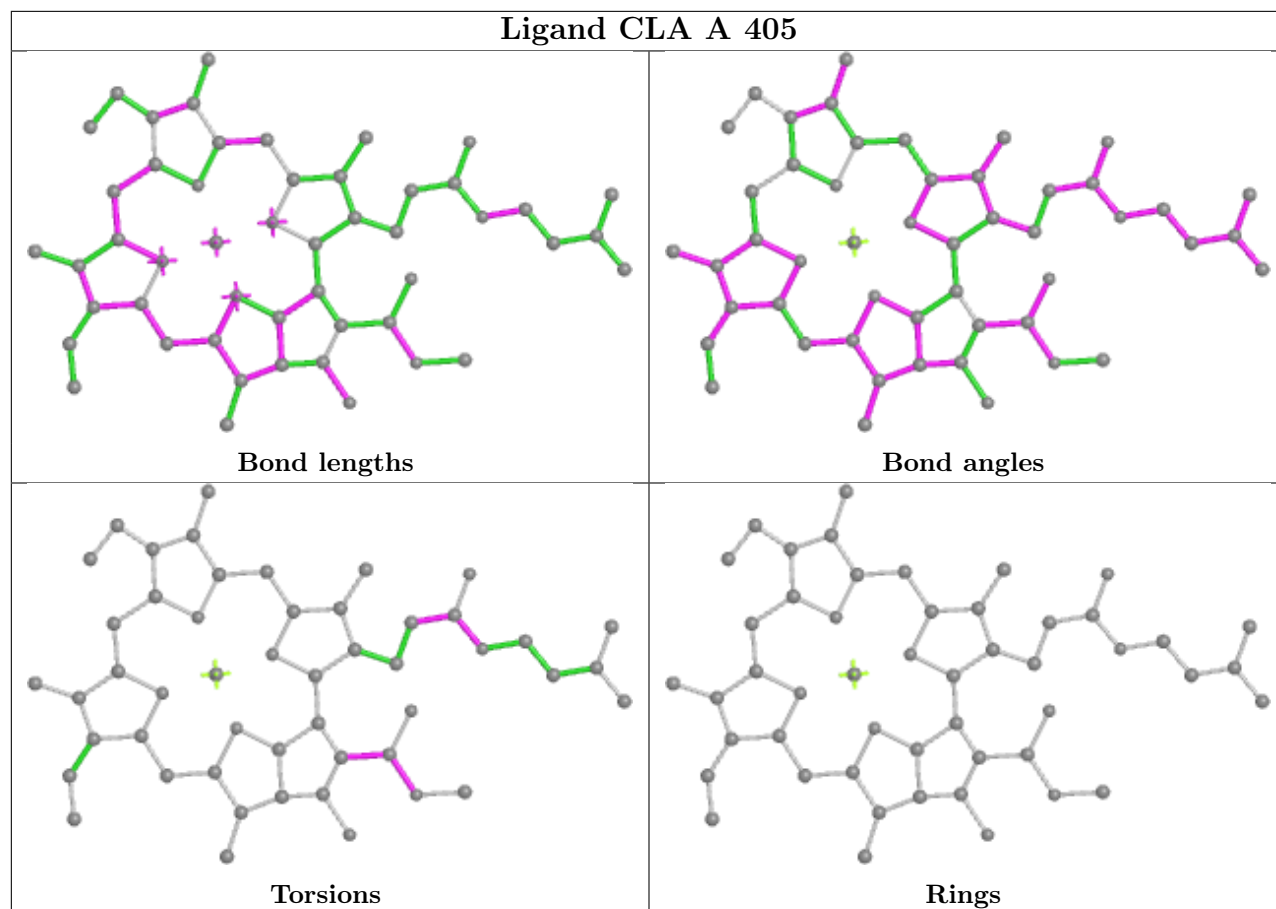

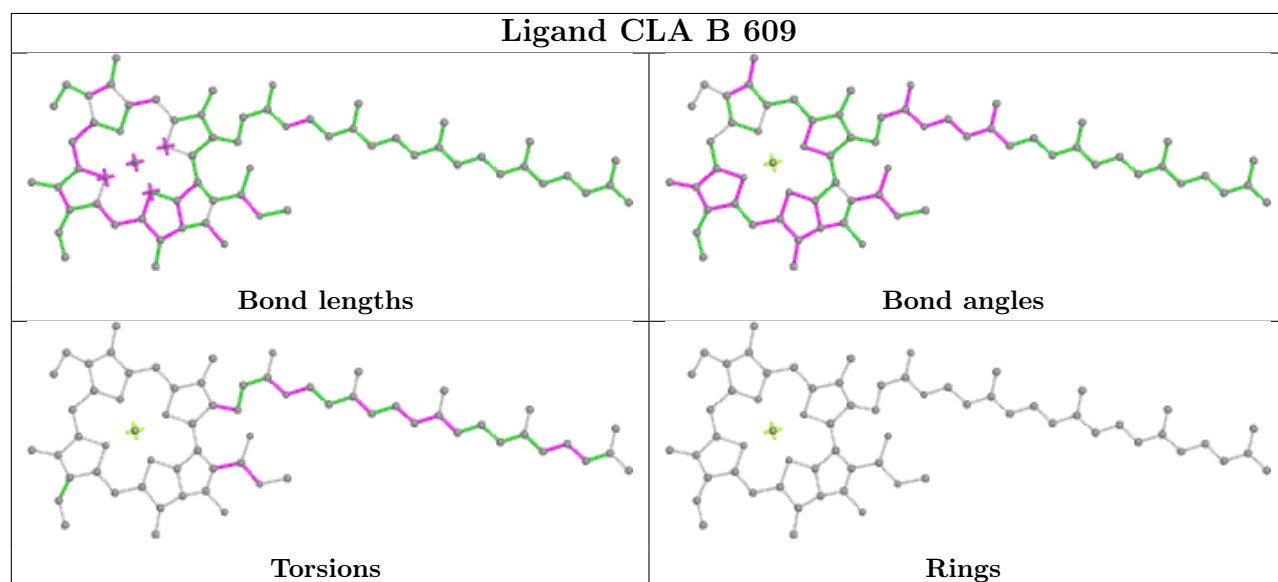
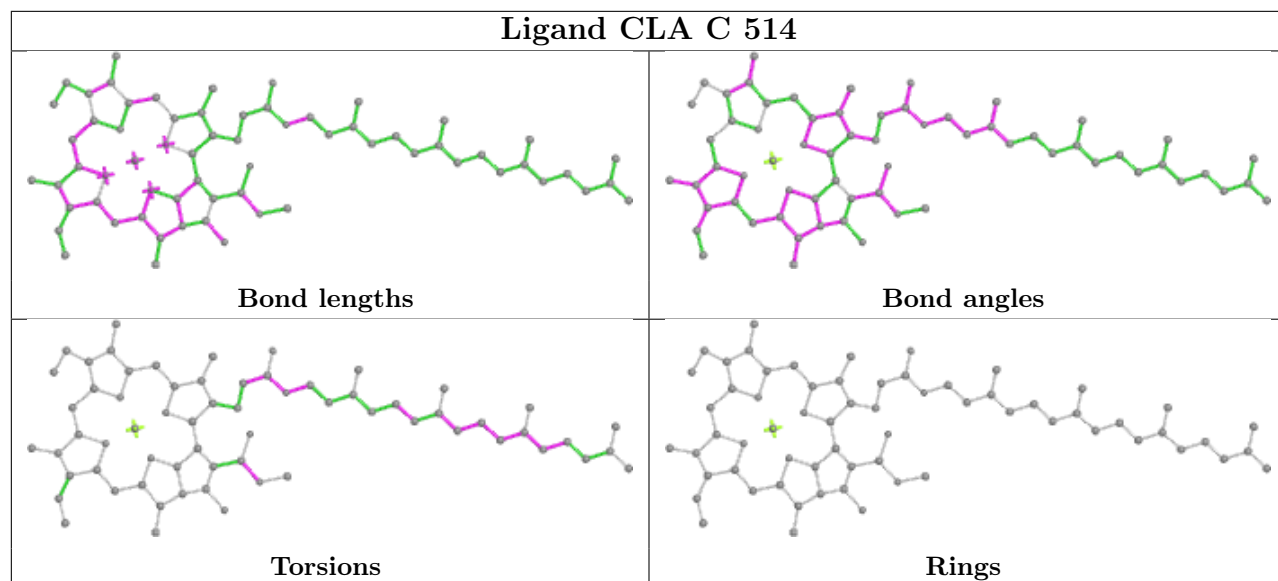
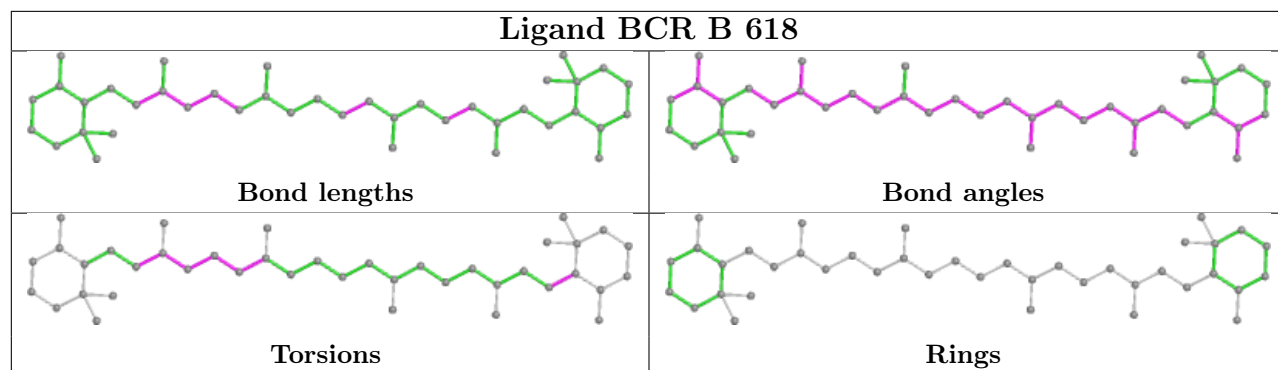

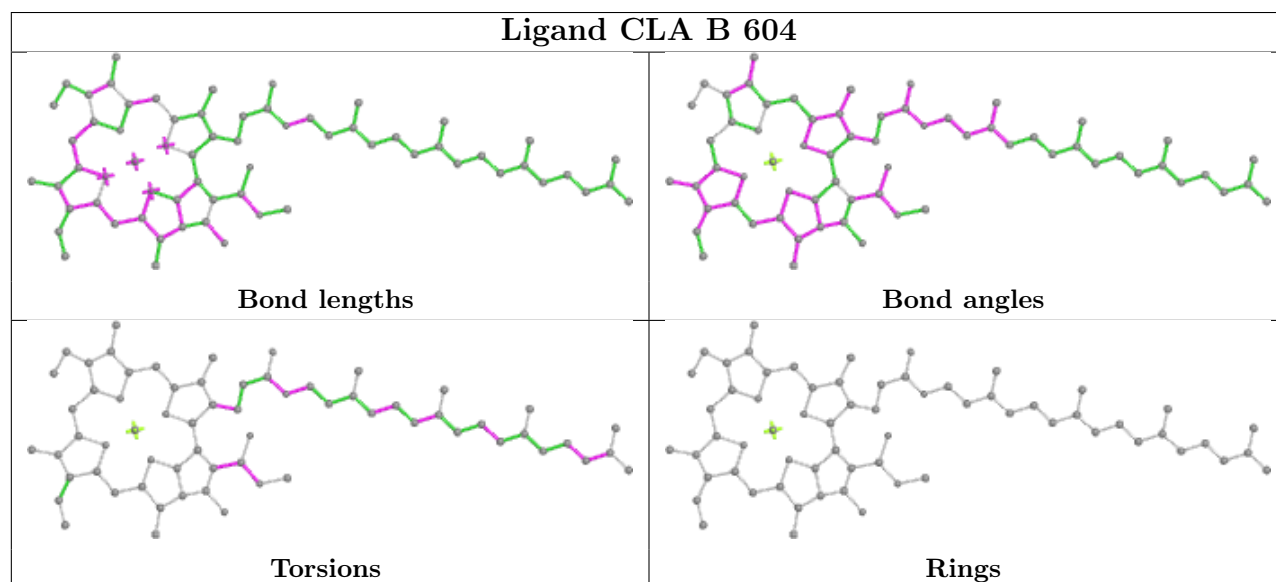
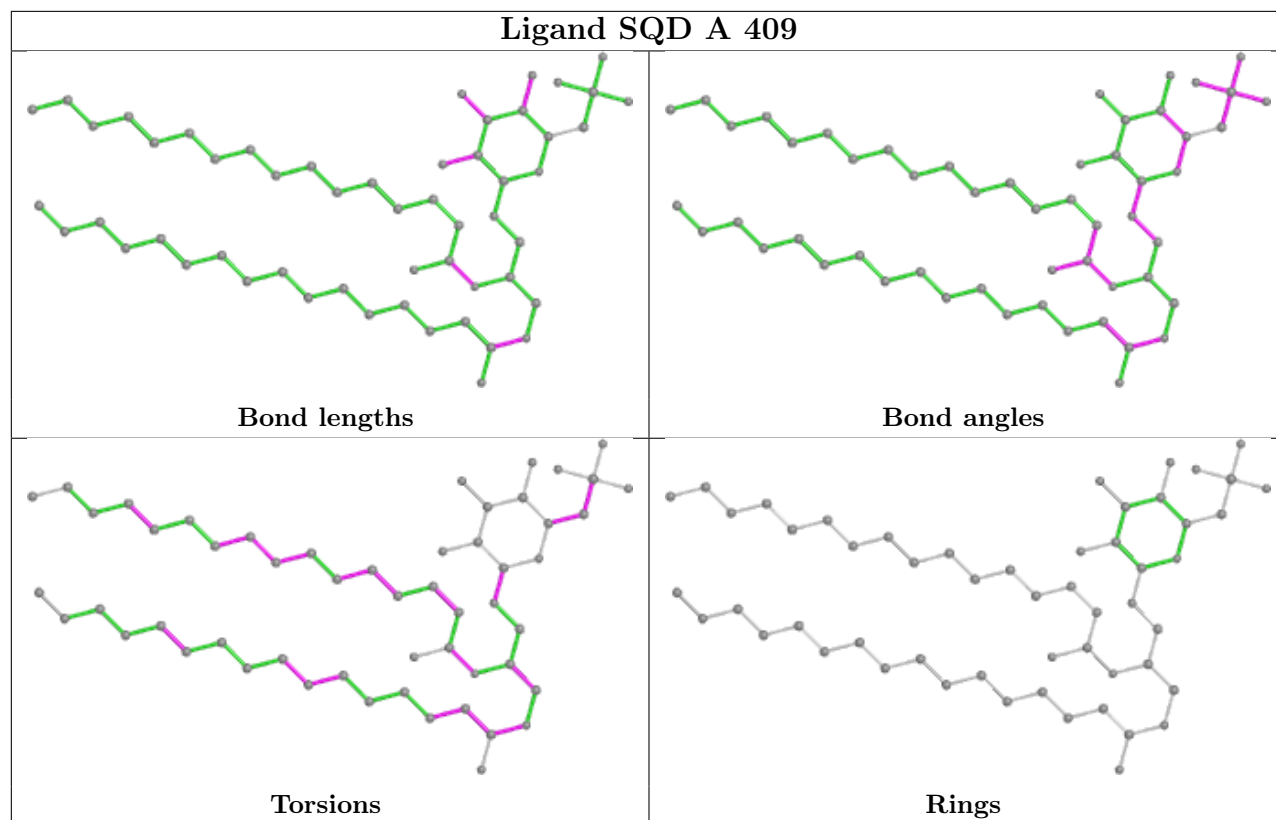

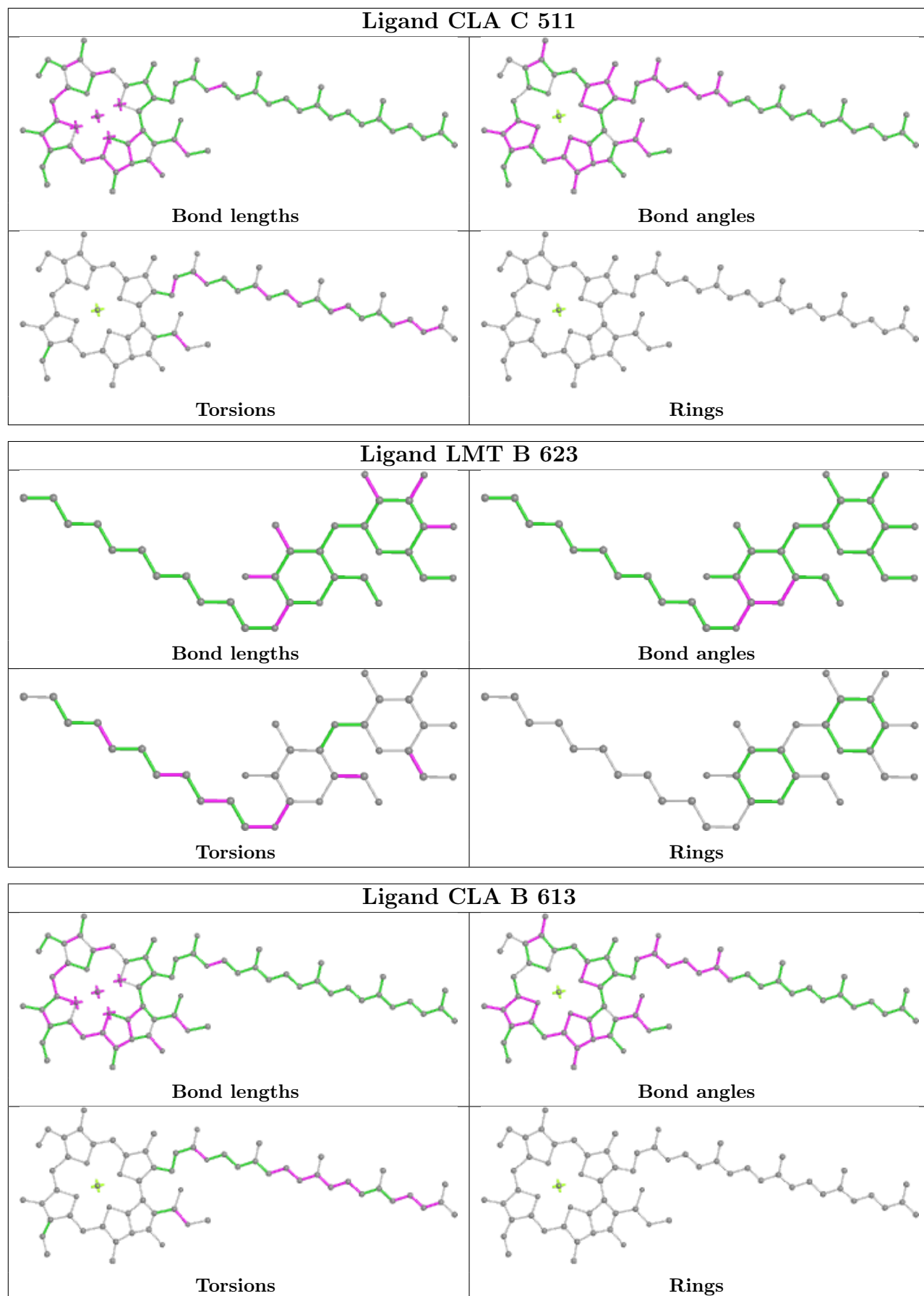

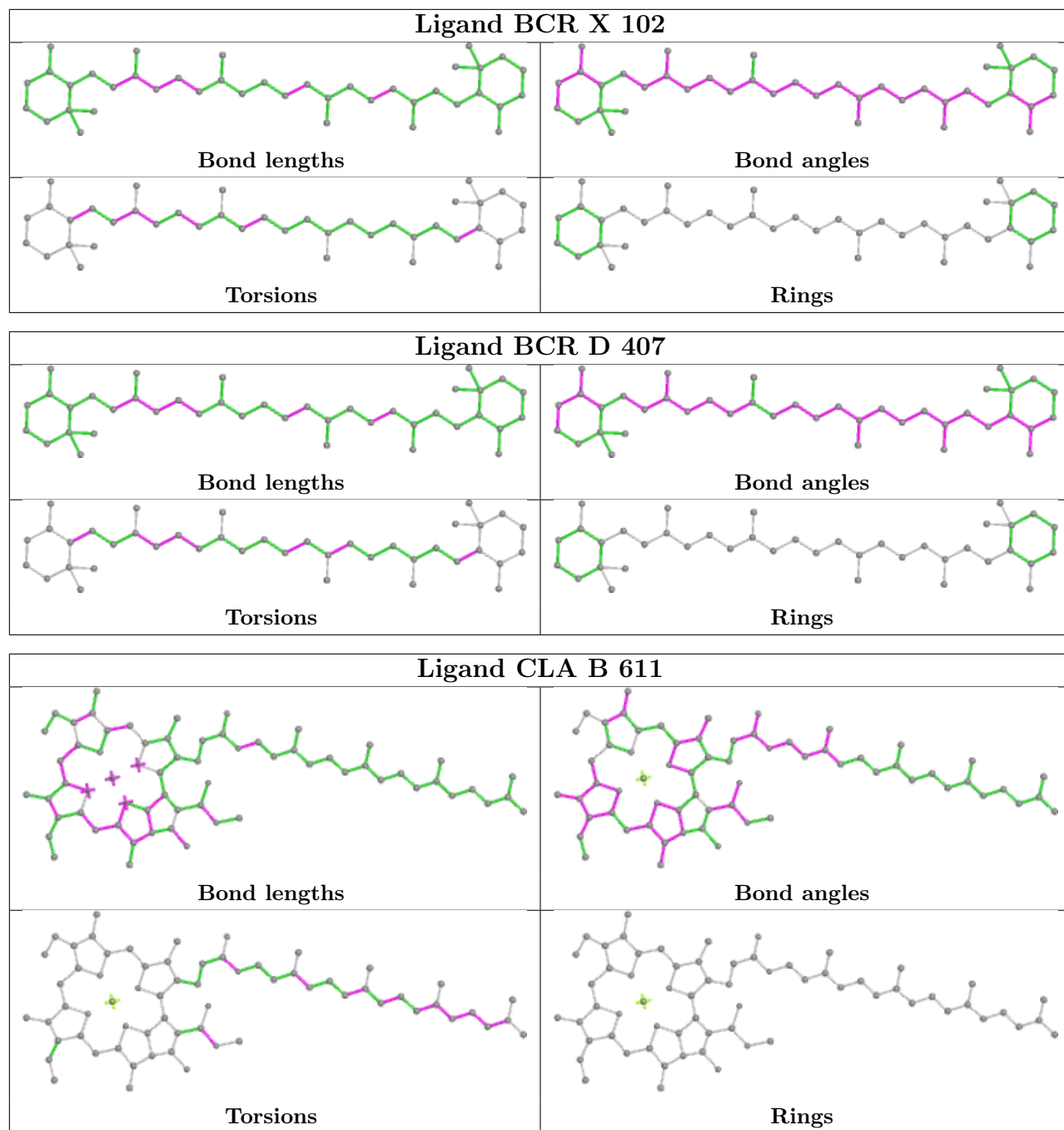

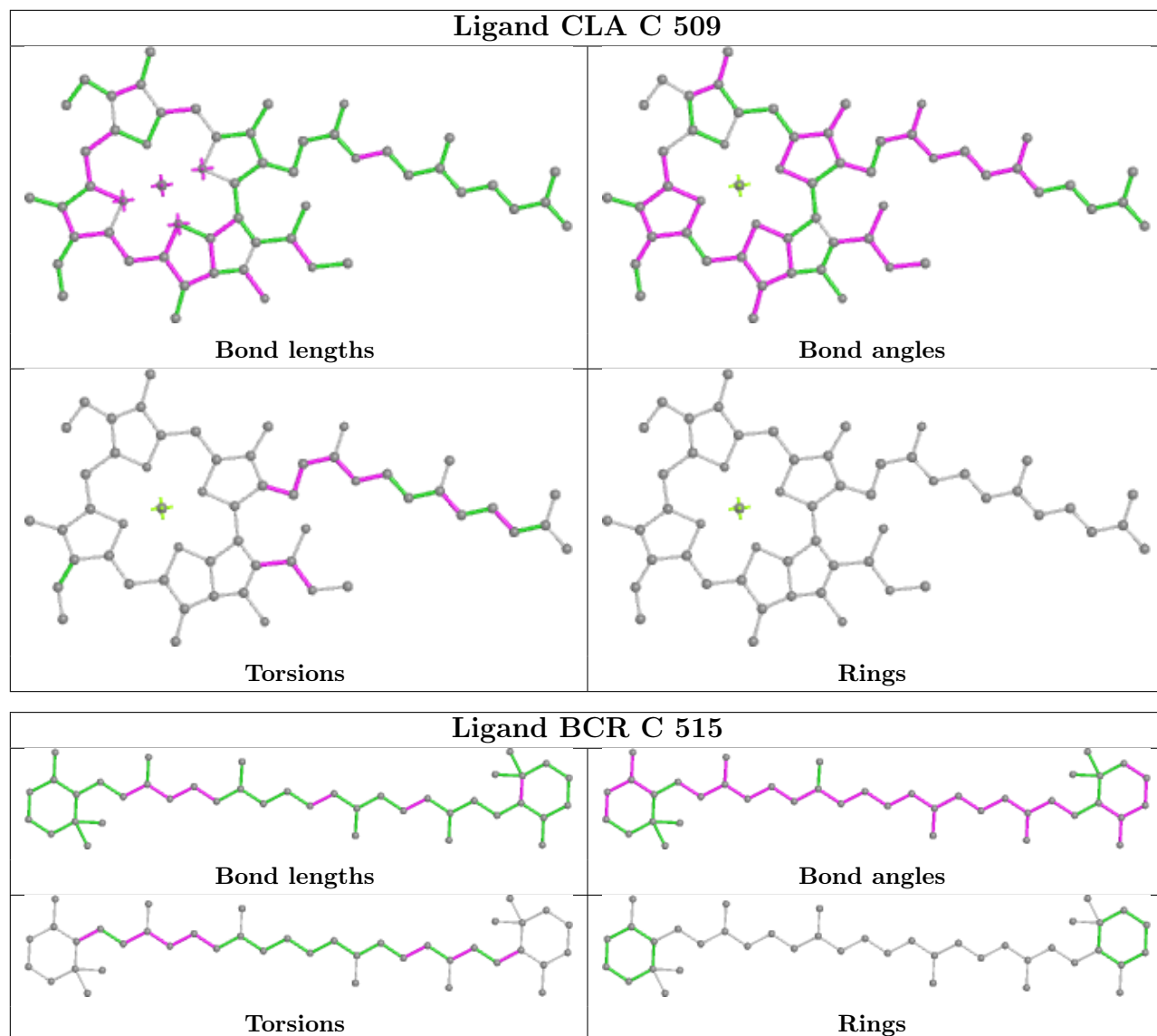

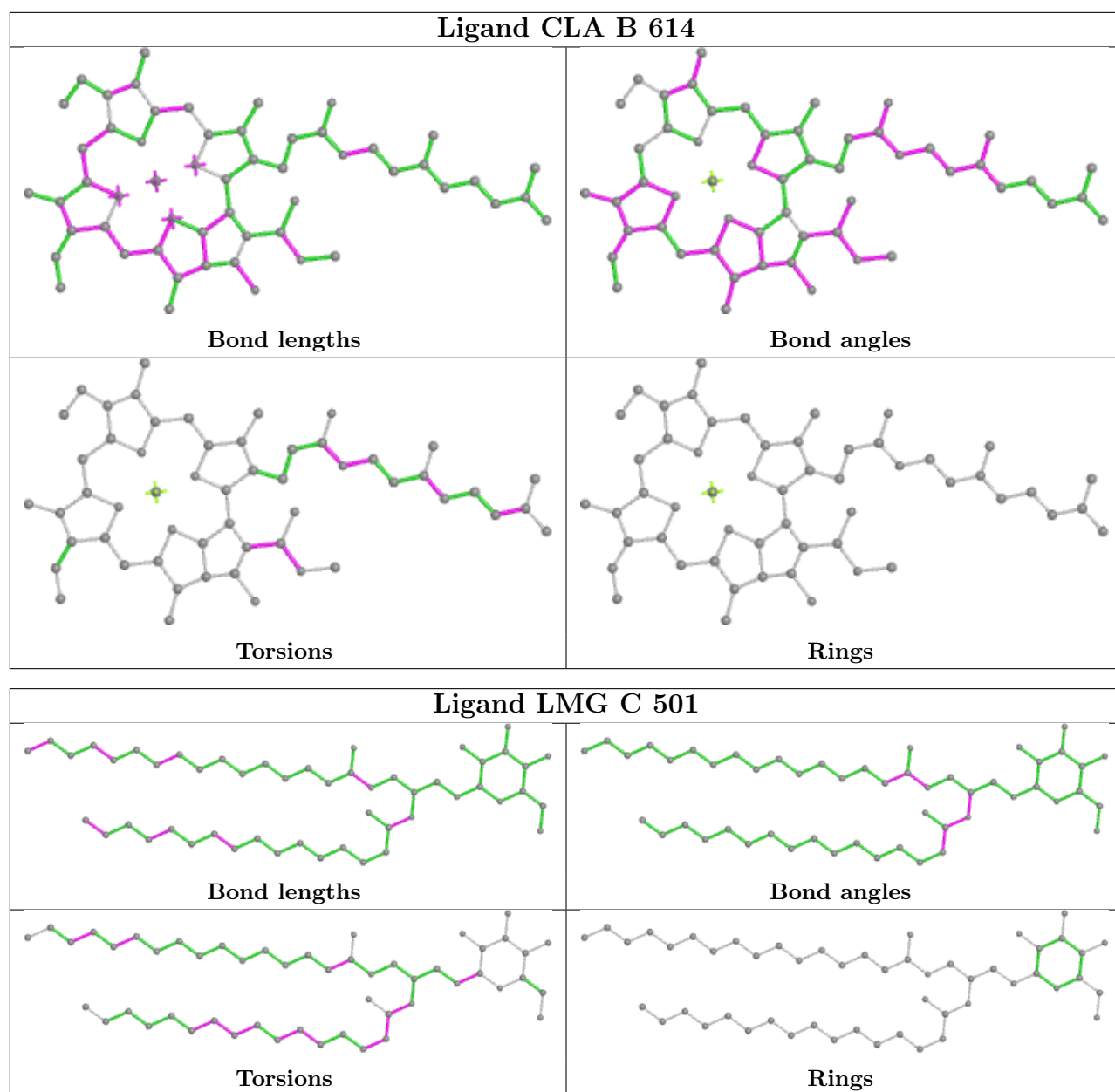

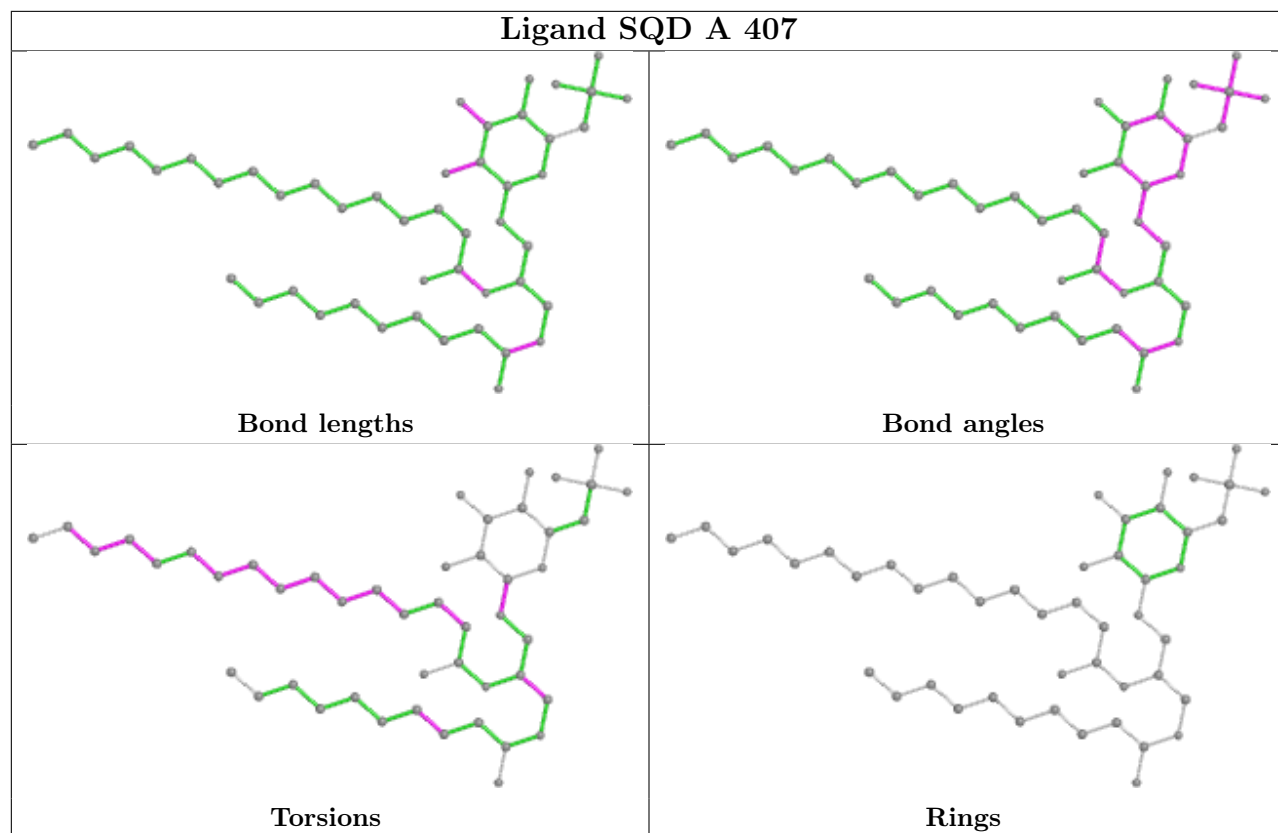

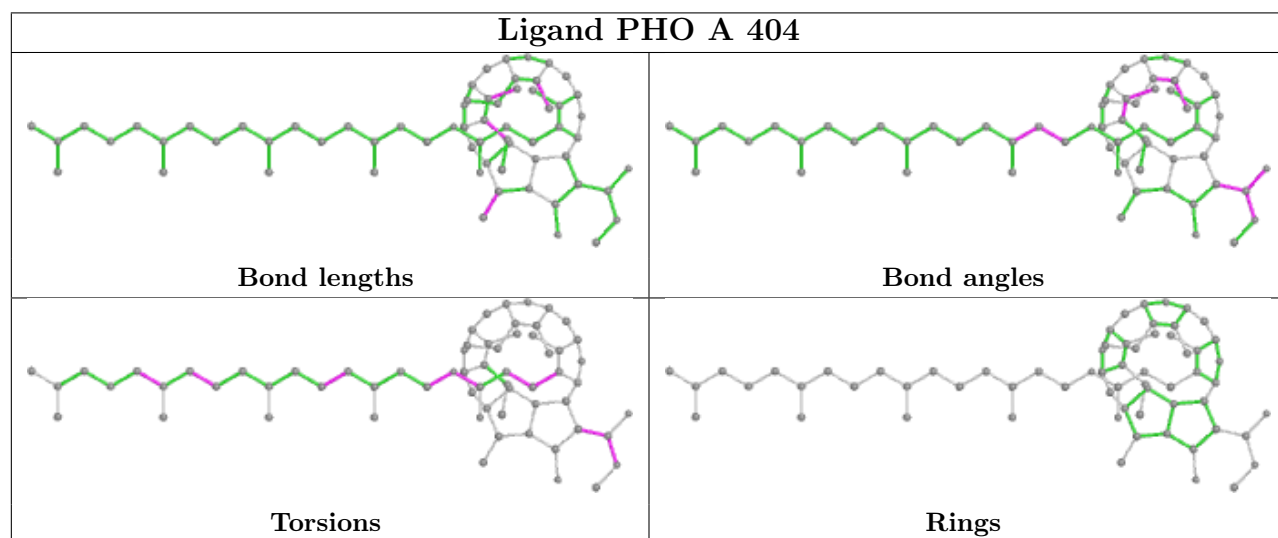
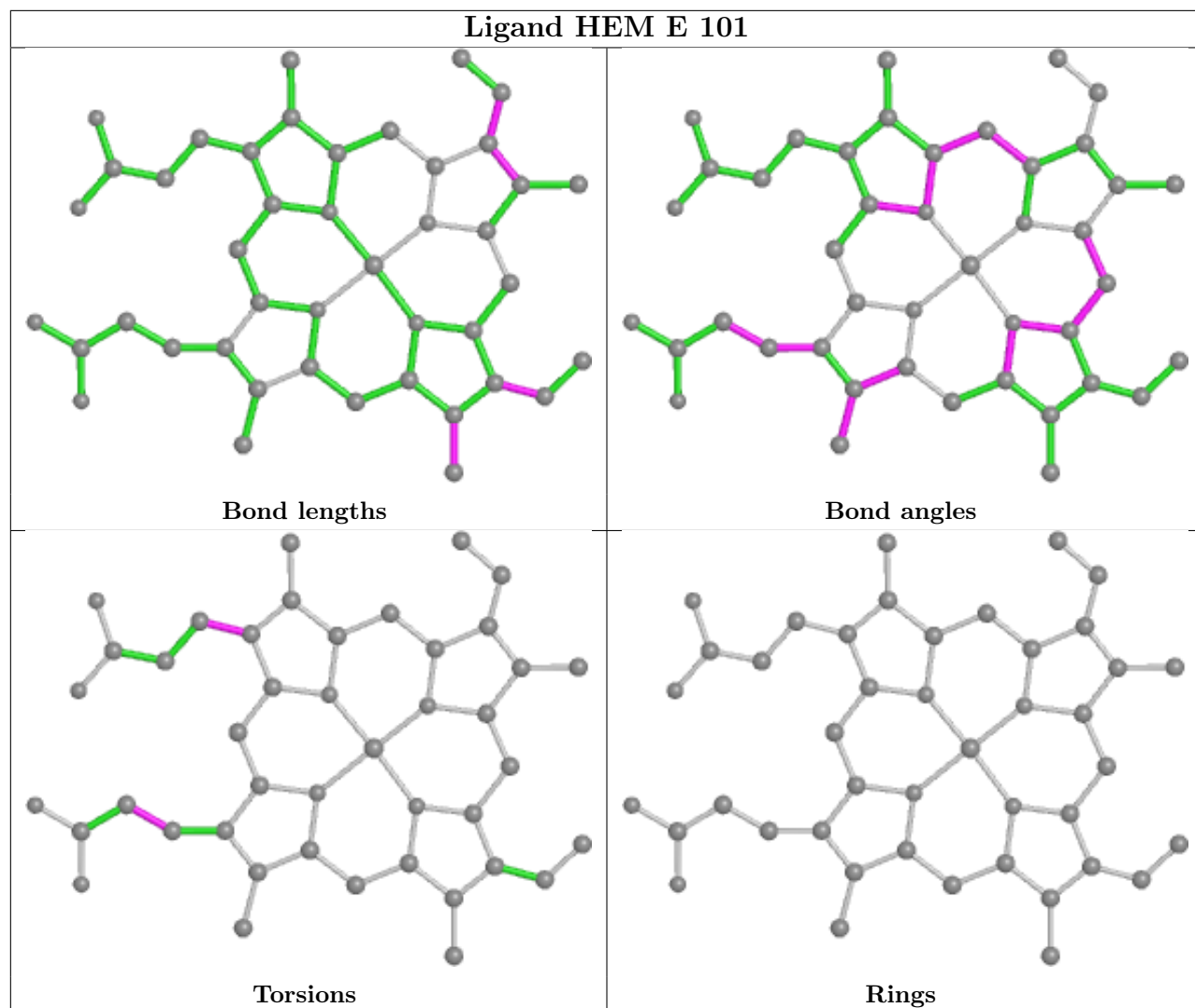

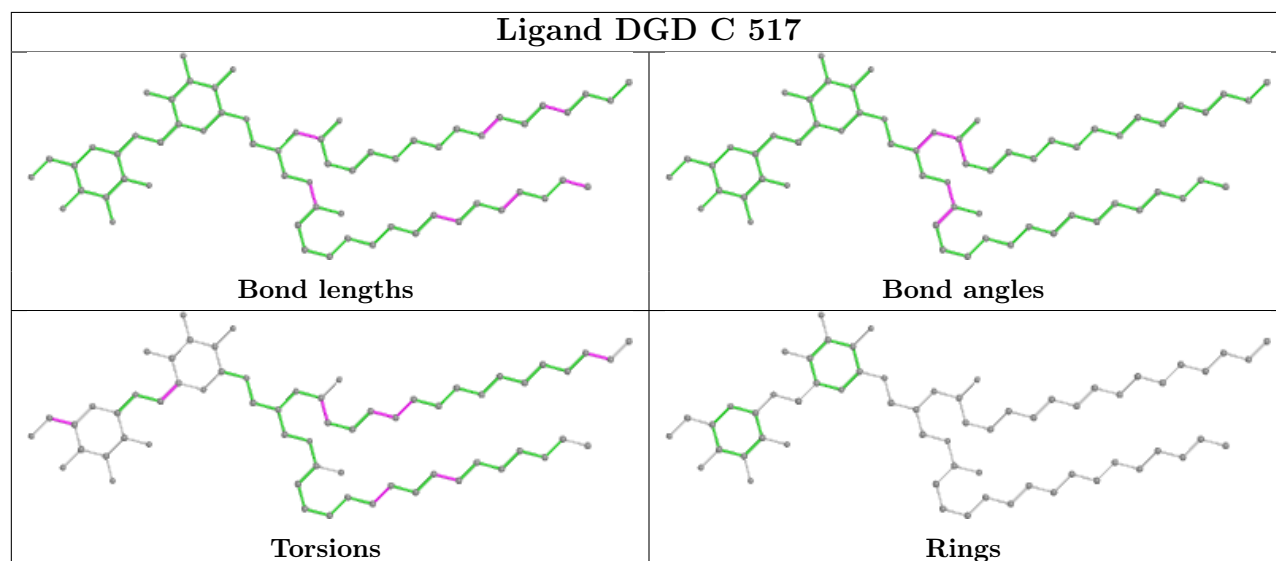
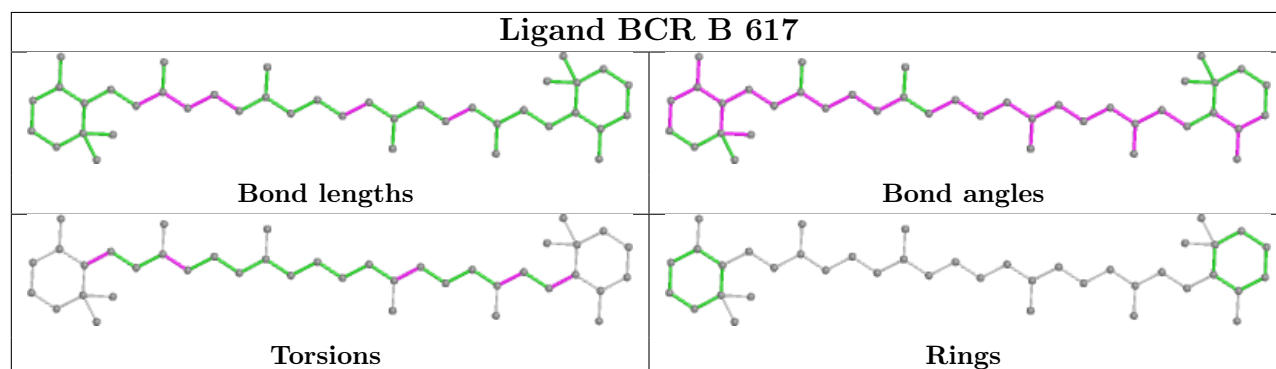
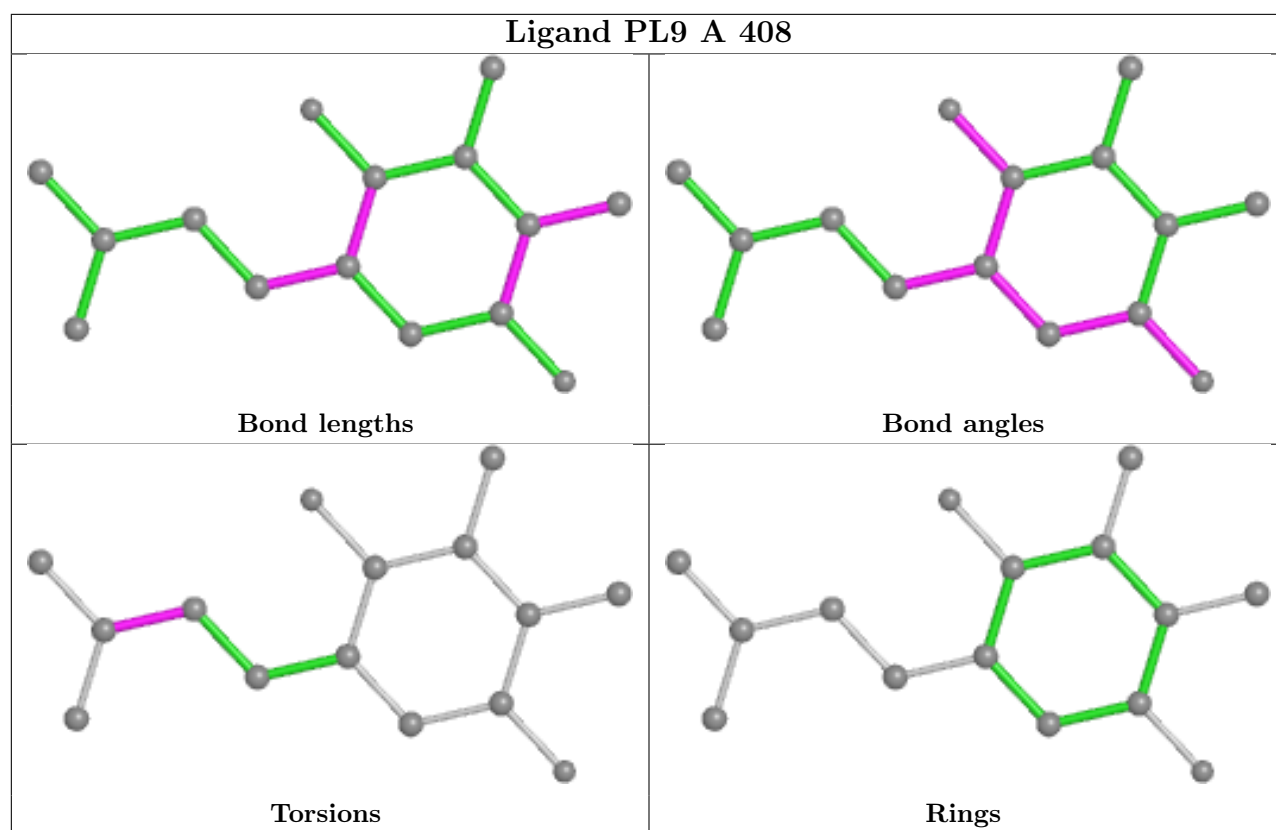

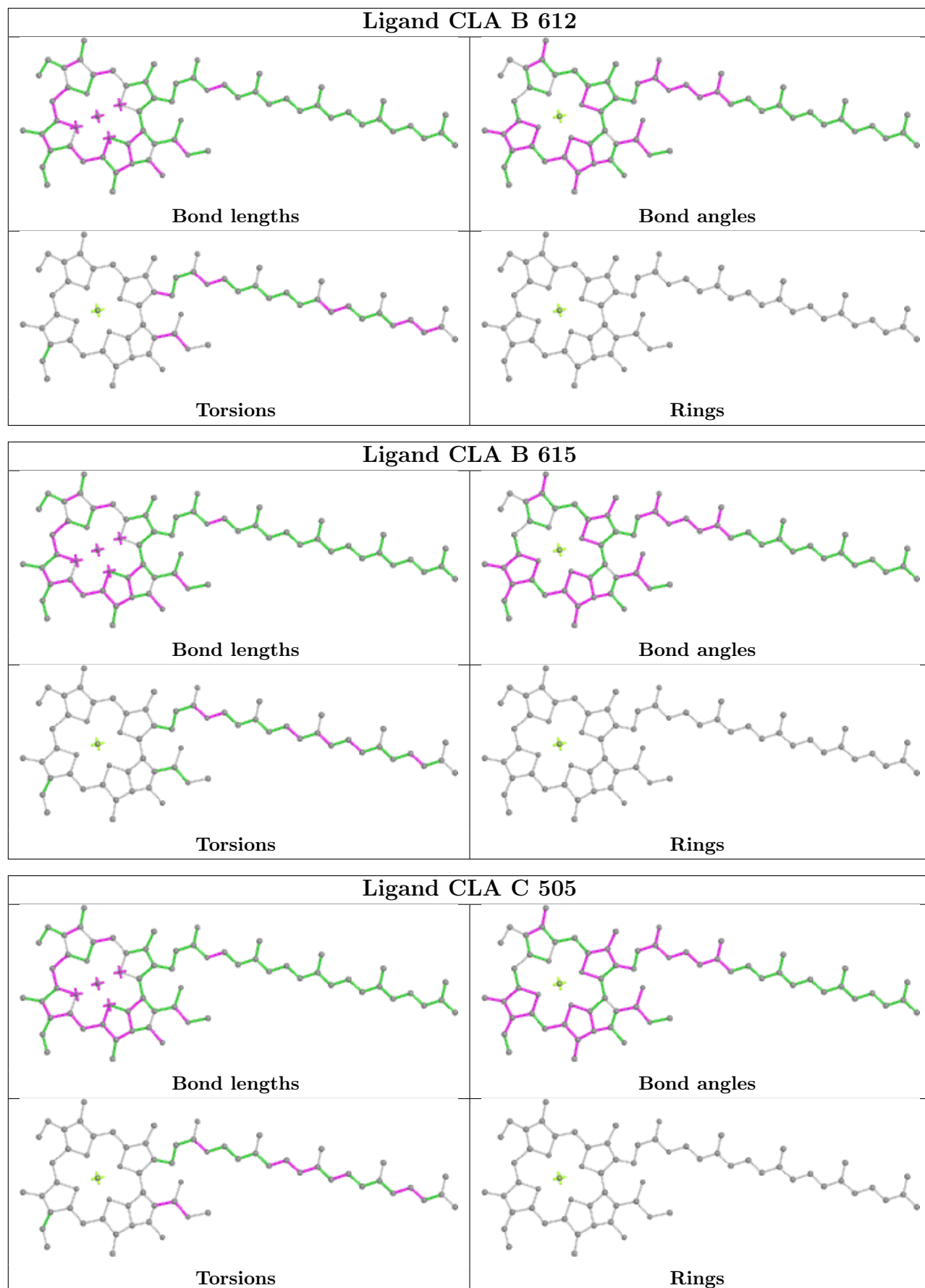

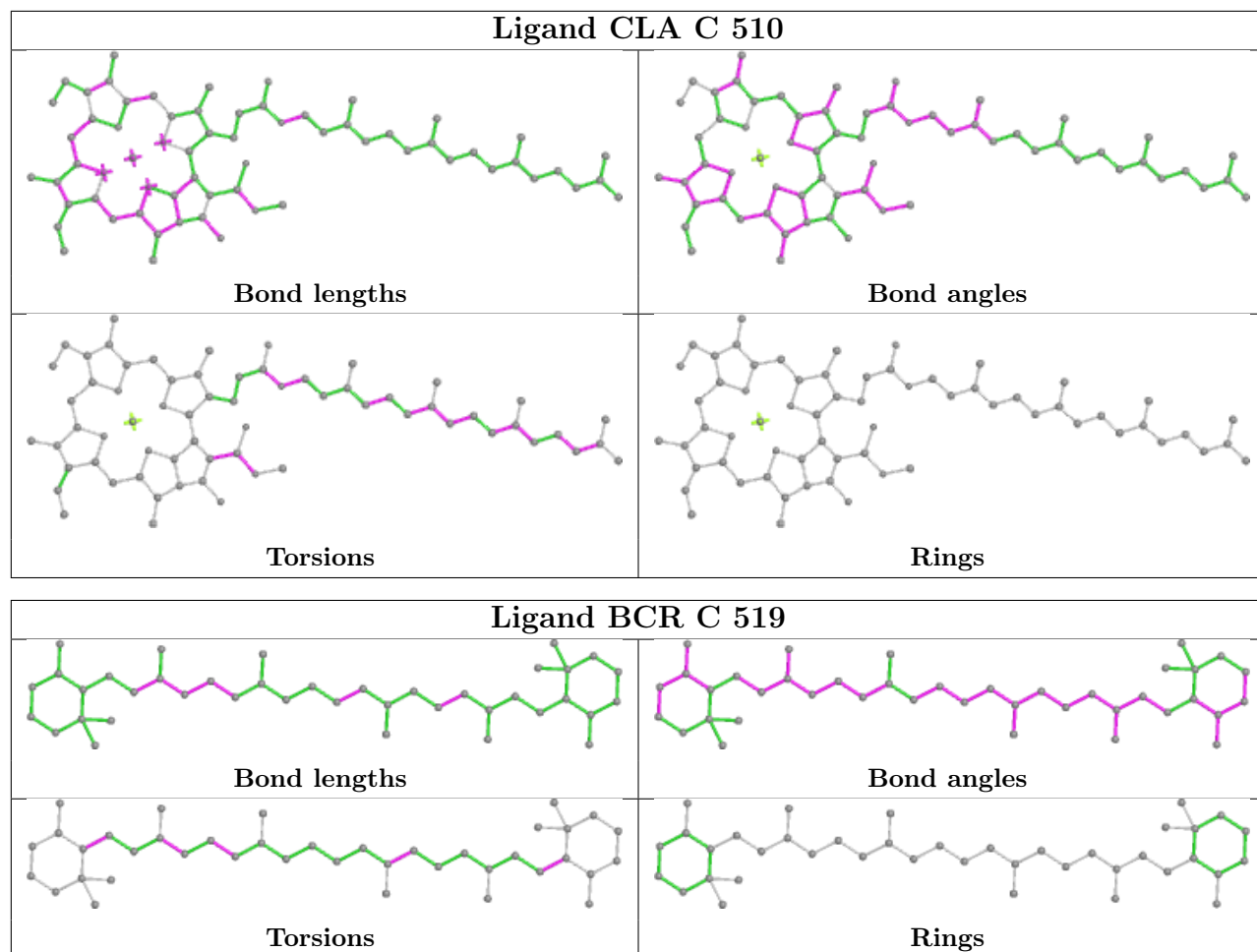

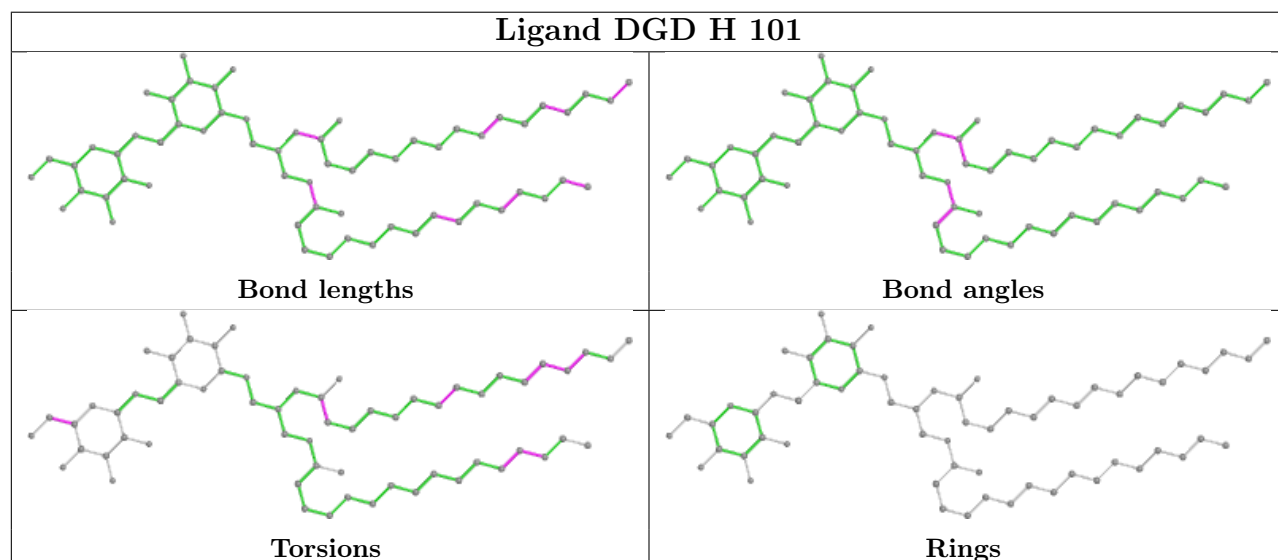
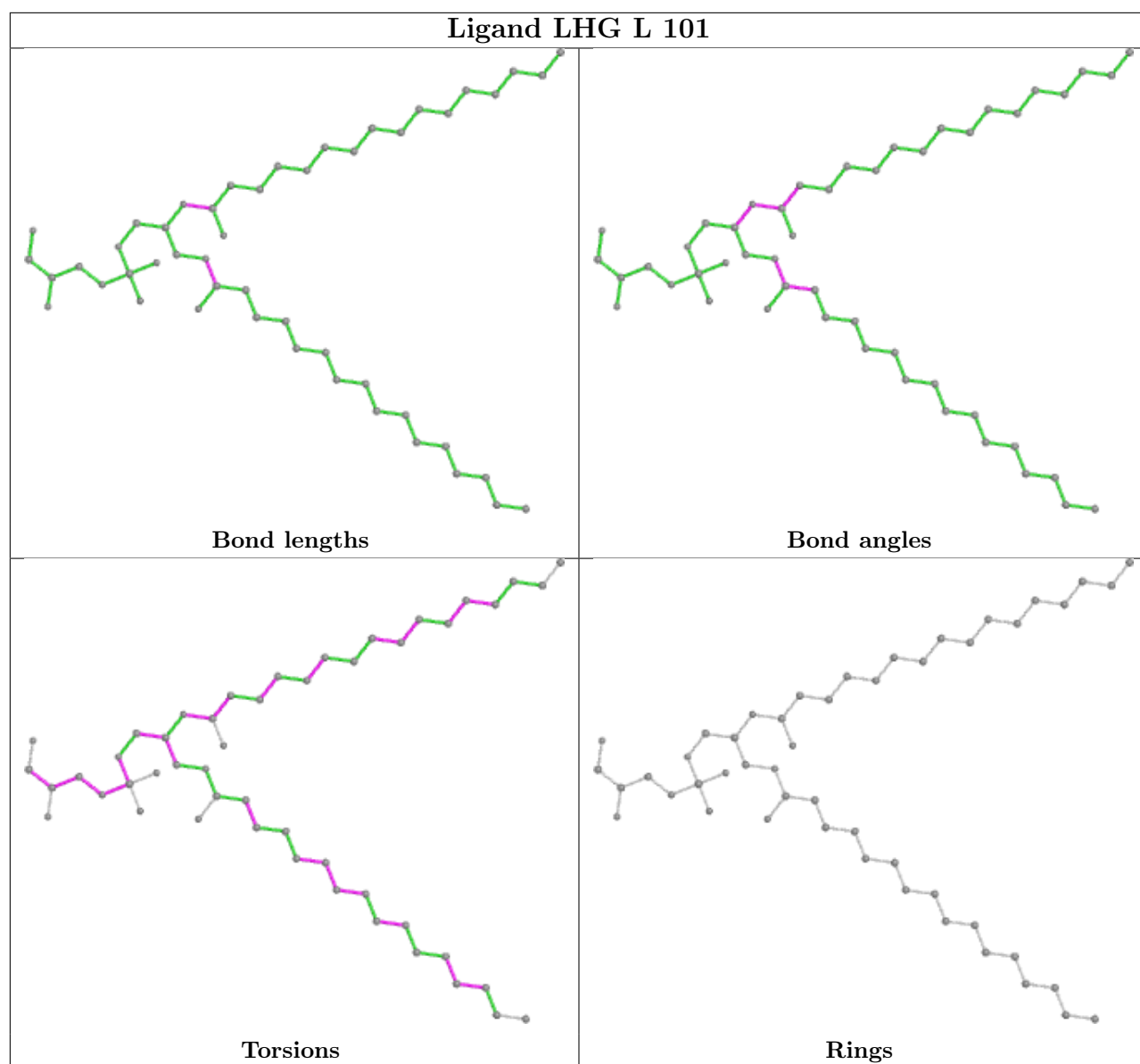

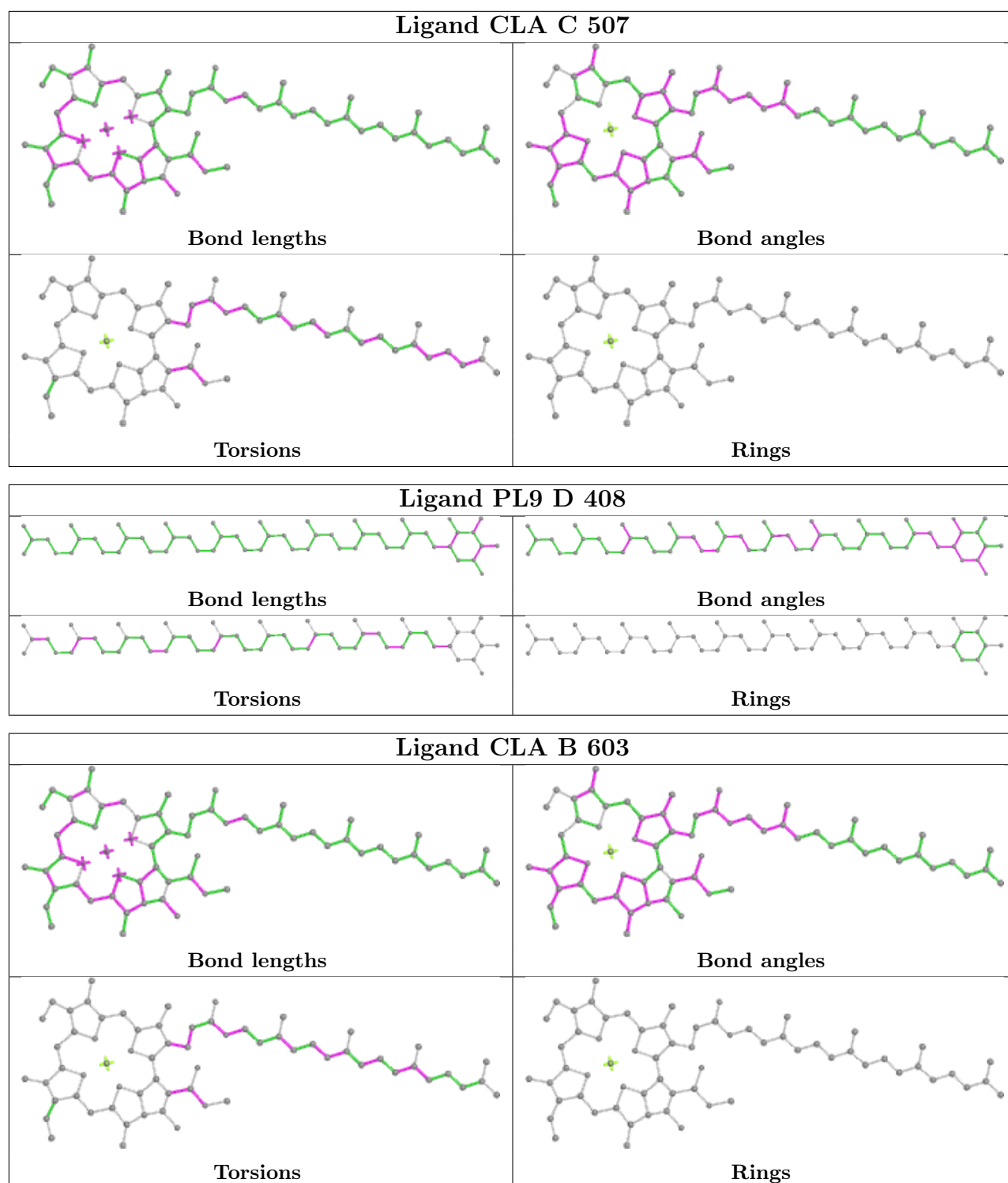

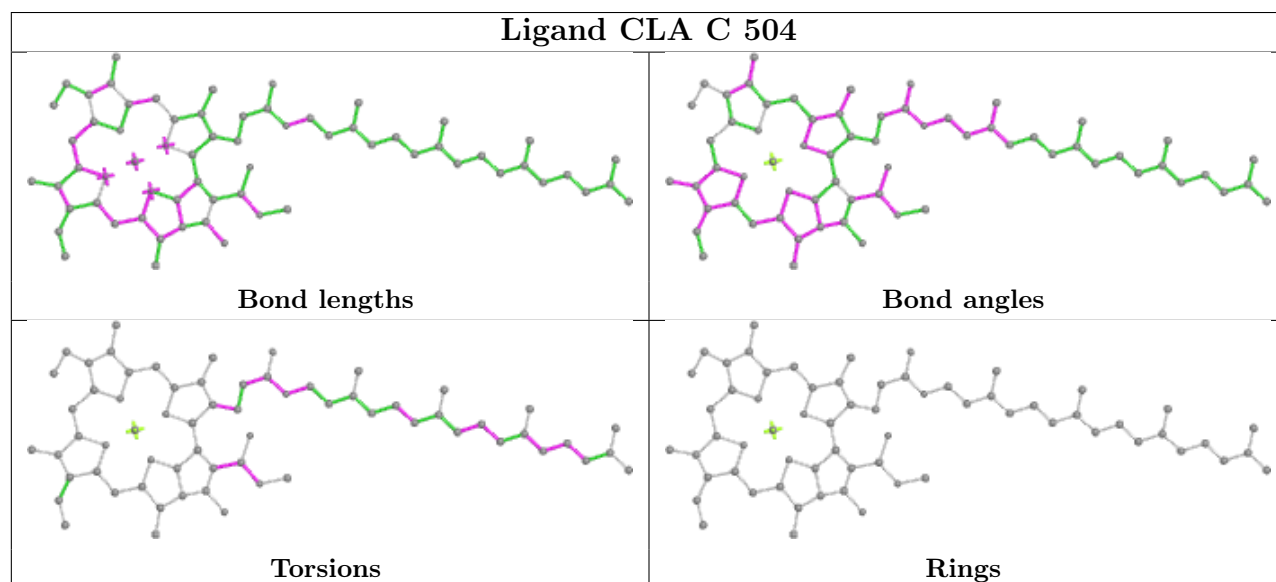
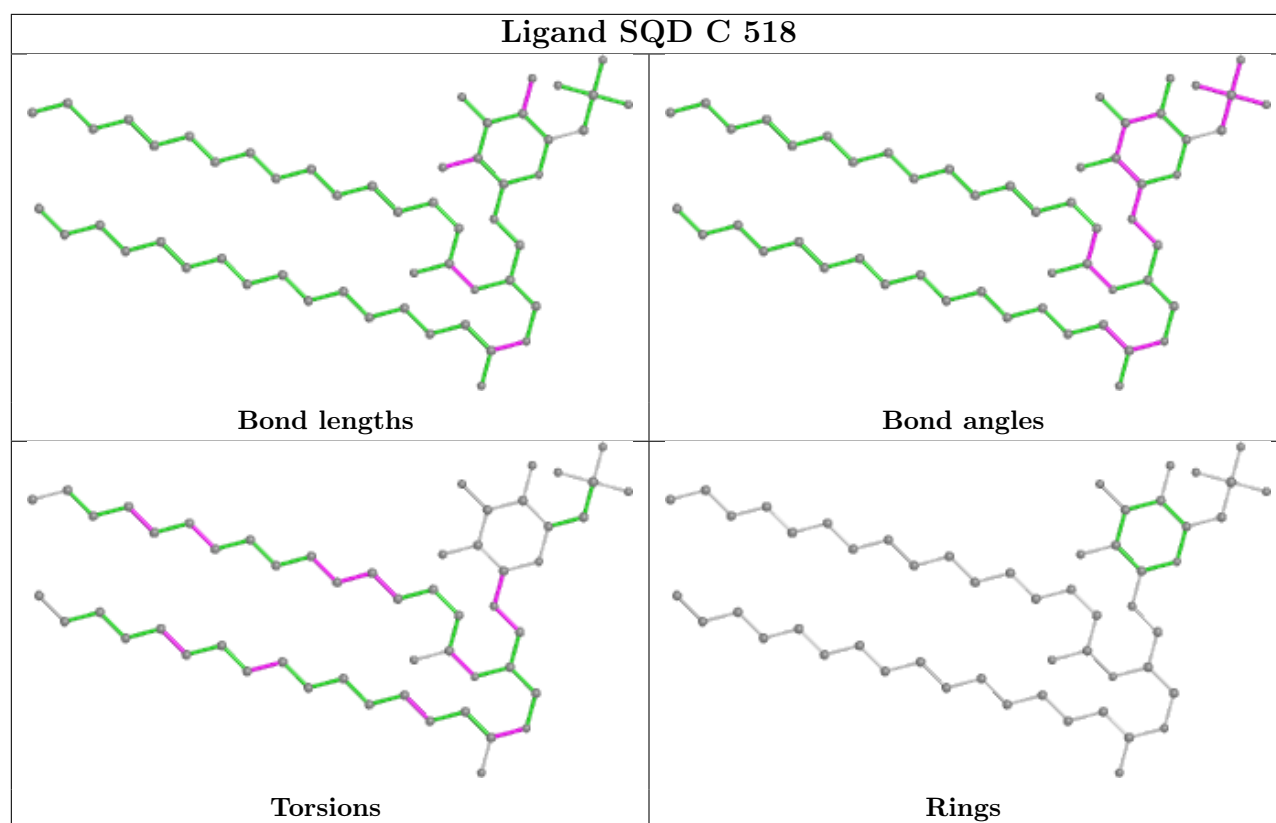

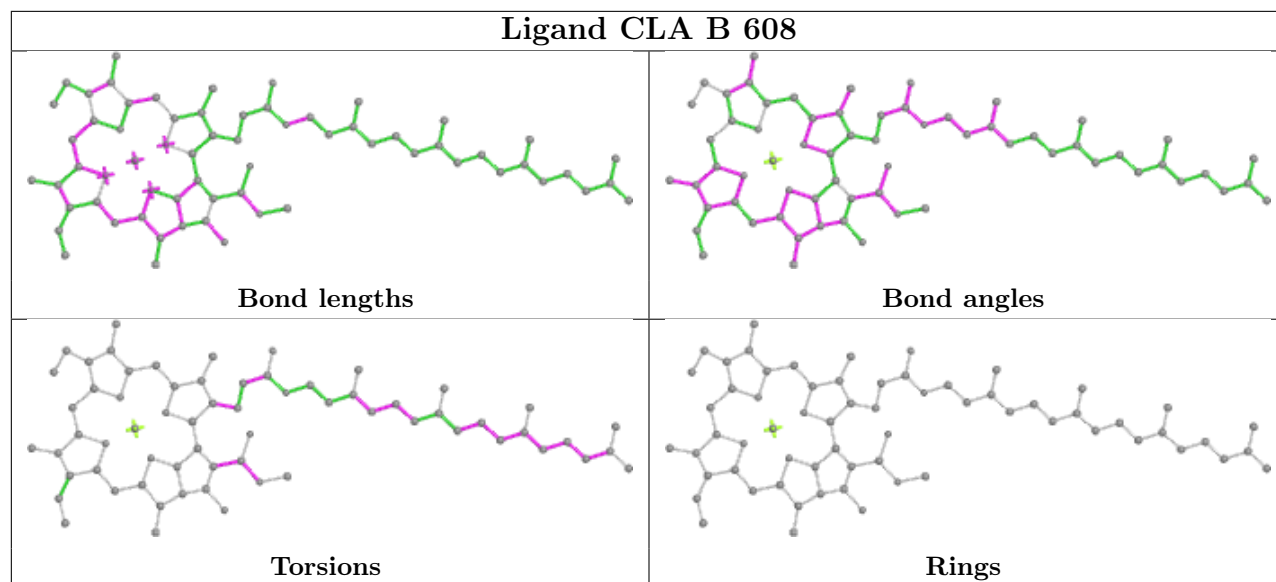

5.7 Other polymers [i](#)

There are no such residues in this entry.

5.8 Polymer linkage issues [i](#)

There are no chain breaks in this entry.

6 Map visualisation [i](#)

This section contains visualisations of the EMDB entry EMD-21690. These allow visual inspection of the internal detail of the map and identification of artifacts.

No raw map or half-maps were deposited for this entry and therefore no images, graphs, etc. pertaining to the raw map can be shown.

6.1 Orthogonal projections [i](#)

6.1.1 Primary map

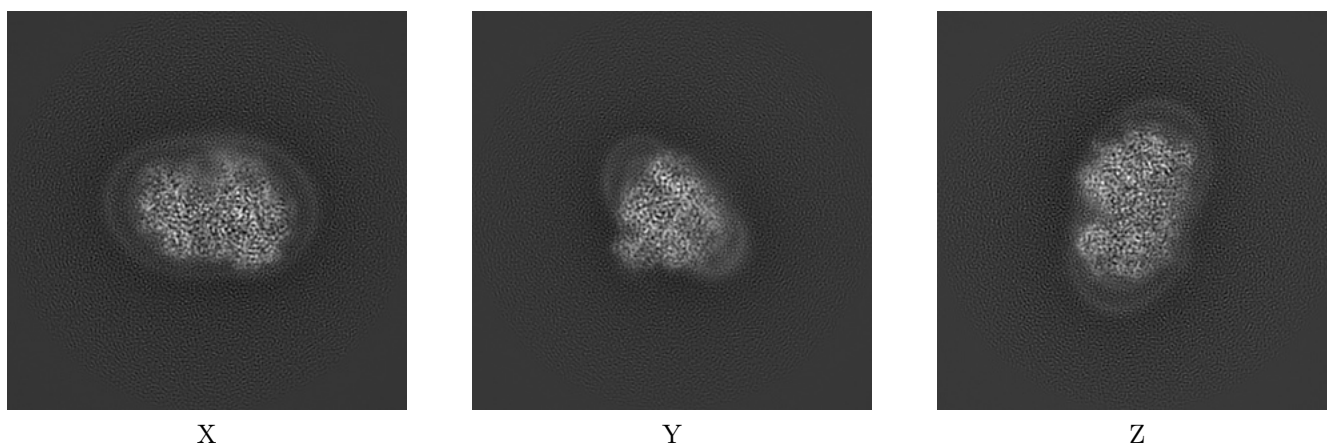

The images above show the map projected in three orthogonal directions.

6.2 Central slices [i](#)

6.2.1 Primary map

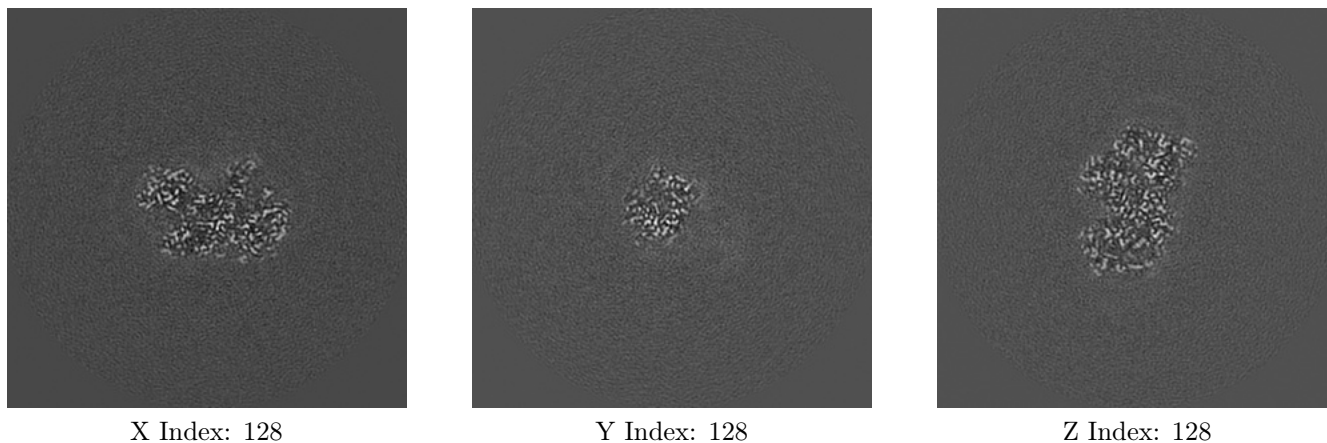

The images above show central slices of the map in three orthogonal directions.

6.3 Largest variance slices [i](#)

6.3.1 Primary map

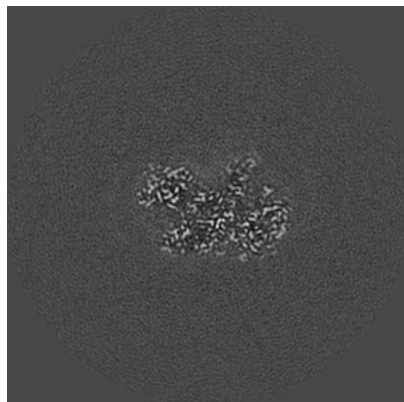

X Index: 128

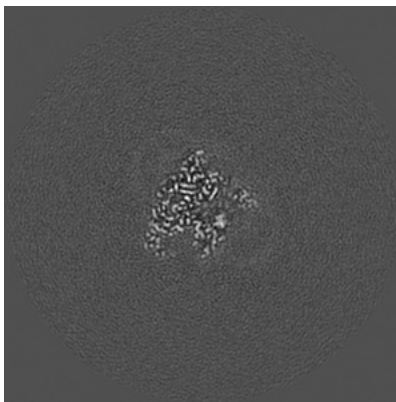

Y Index: 155

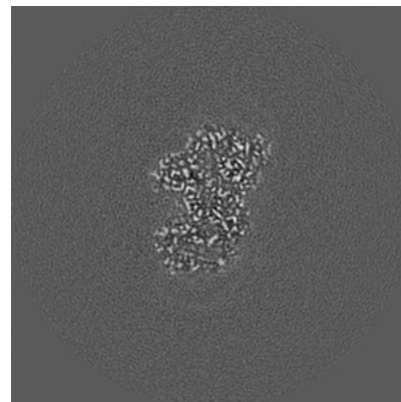

Z Index: 127

The images above show the largest variance slices of the map in three orthogonal directions.

6.4 Orthogonal standard-deviation projections (False-color) [i](#)

6.4.1 Primary map

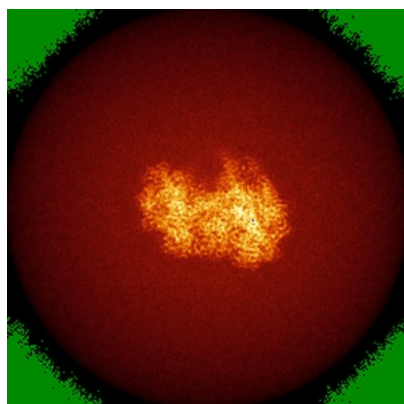

X

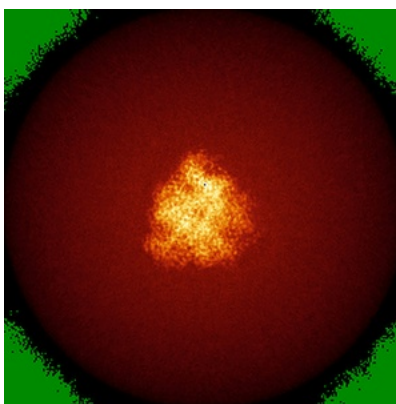

Y

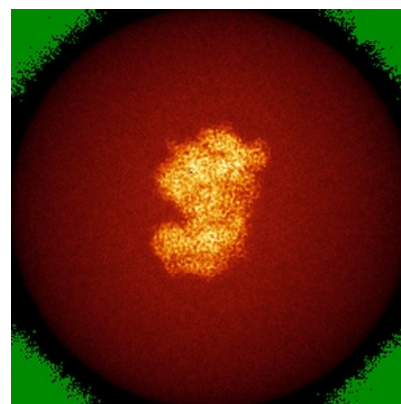

Z

The images above show the map standard deviation projections with false color in three orthogonal directions. Minimum values are shown in green, max in blue, and dark to light orange shades represent small to large values respectively.

6.5 Orthogonal surface views [i](#)

6.5.1 Primary map

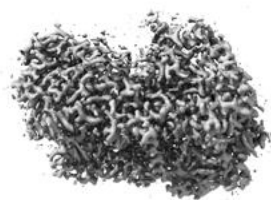

X

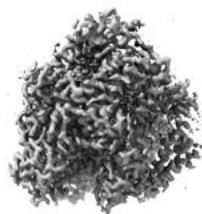

Y



Z

The images above show the 3D surface view of the map at the recommended contour level 0.0394. These images, in conjunction with the slice images, may facilitate assessment of whether an appropriate contour level has been provided.

6.6 Mask visualisation [i](#)

This section was not generated. No masks/segmentation were deposited.

7 Map analysis [i](#)

This section contains the results of statistical analysis of the map.

7.1 Map-value distribution [i](#)

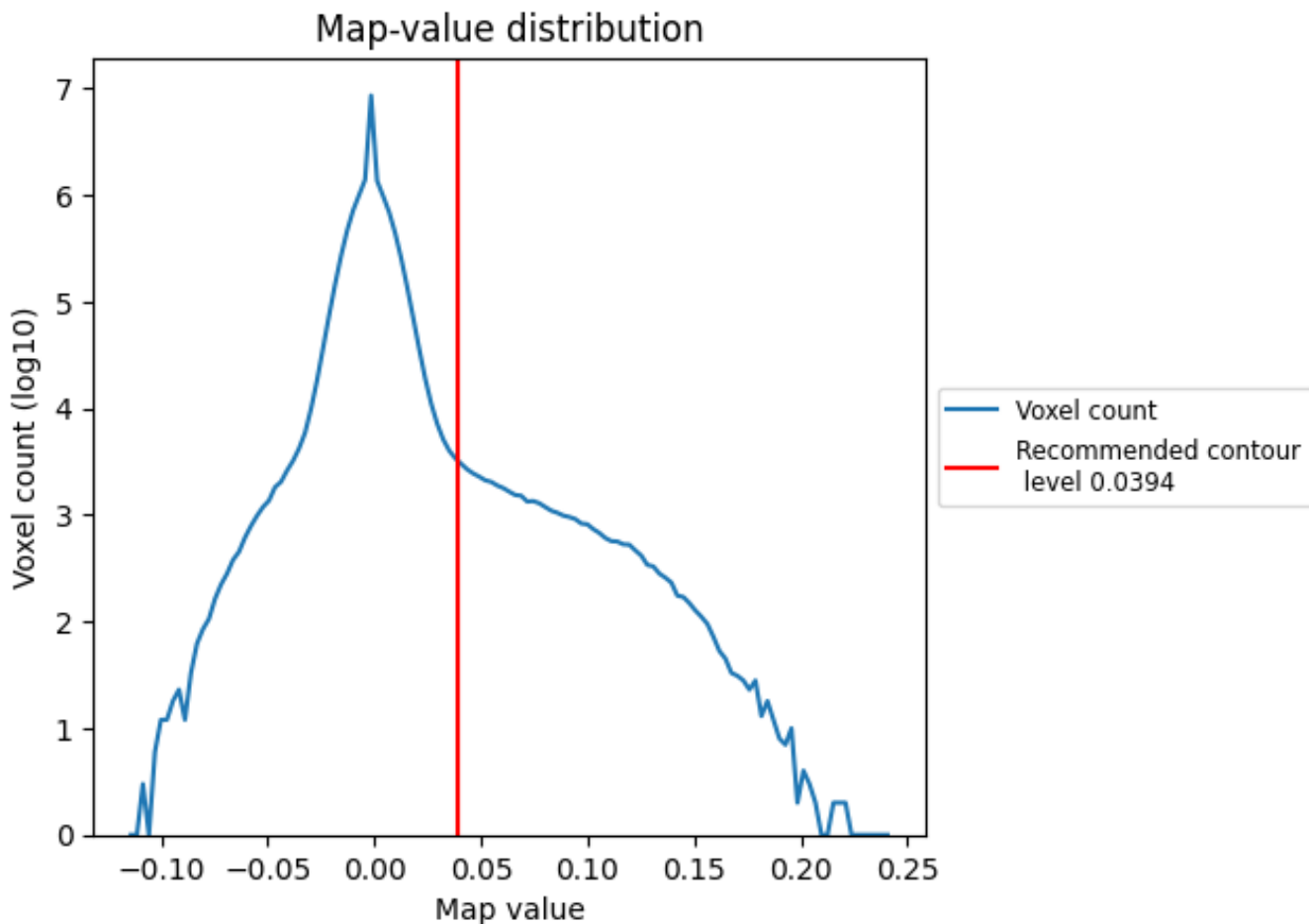

The map-value distribution is plotted in 128 intervals along the x-axis. The y-axis is logarithmic. A spike in this graph at zero usually indicates that the volume has been masked.

7.2 Volume estimate [\(i\)](#)

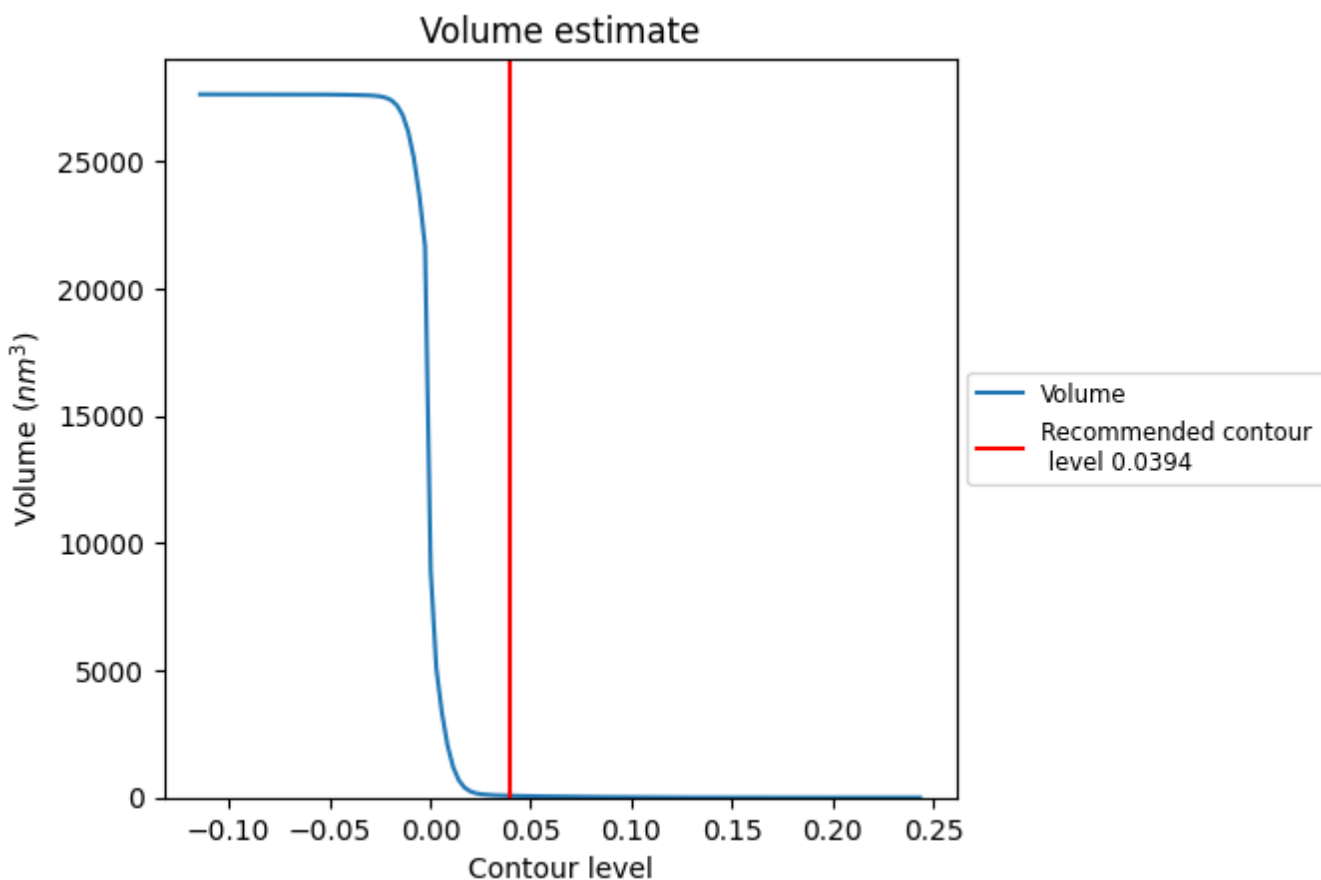

The volume at the recommended contour level is 73 nm³; this corresponds to an approximate mass of 66 kDa.

The volume estimate graph shows how the enclosed volume varies with the contour level. The recommended contour level is shown as a vertical line and the intersection between the line and the curve gives the volume of the enclosed surface at the given level.

7.3 Rotationally averaged power spectrum [i](#)

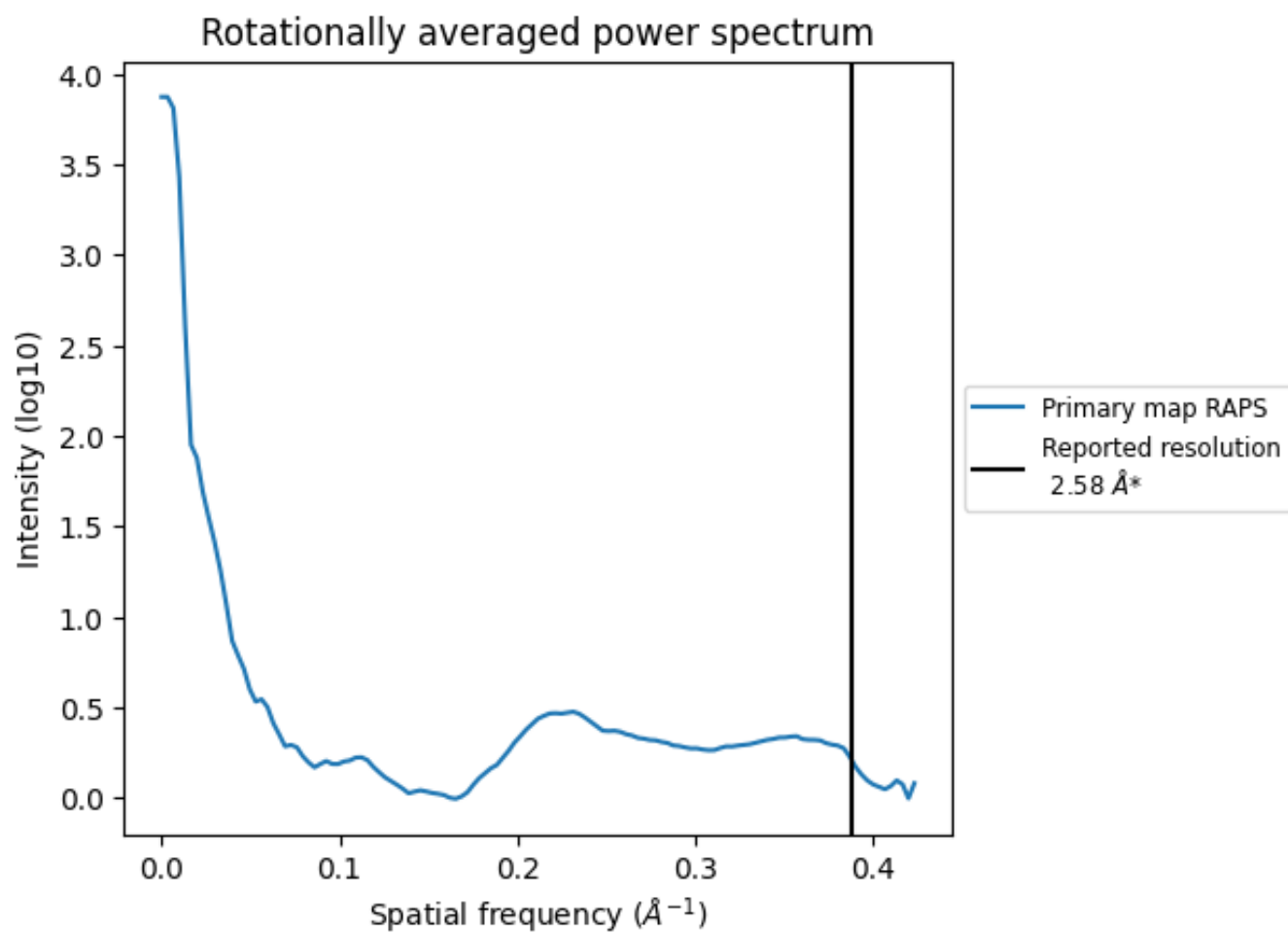

*Reported resolution corresponds to spatial frequency of 0.388 Å⁻¹

8 Fourier-Shell correlation [i](#)

Fourier-Shell Correlation (FSC) is the most commonly used method to estimate the resolution of single-particle and subtomogram-averaged maps. The shape of the curve depends on the imposed symmetry, mask and whether or not the two 3D reconstructions used were processed from a common reference. The reported resolution is shown as a black line. A curve is displayed for the half-bit criterion in addition to lines showing the 0.143 gold standard cut-off and 0.5 cut-off.

8.1 FSC [i](#)

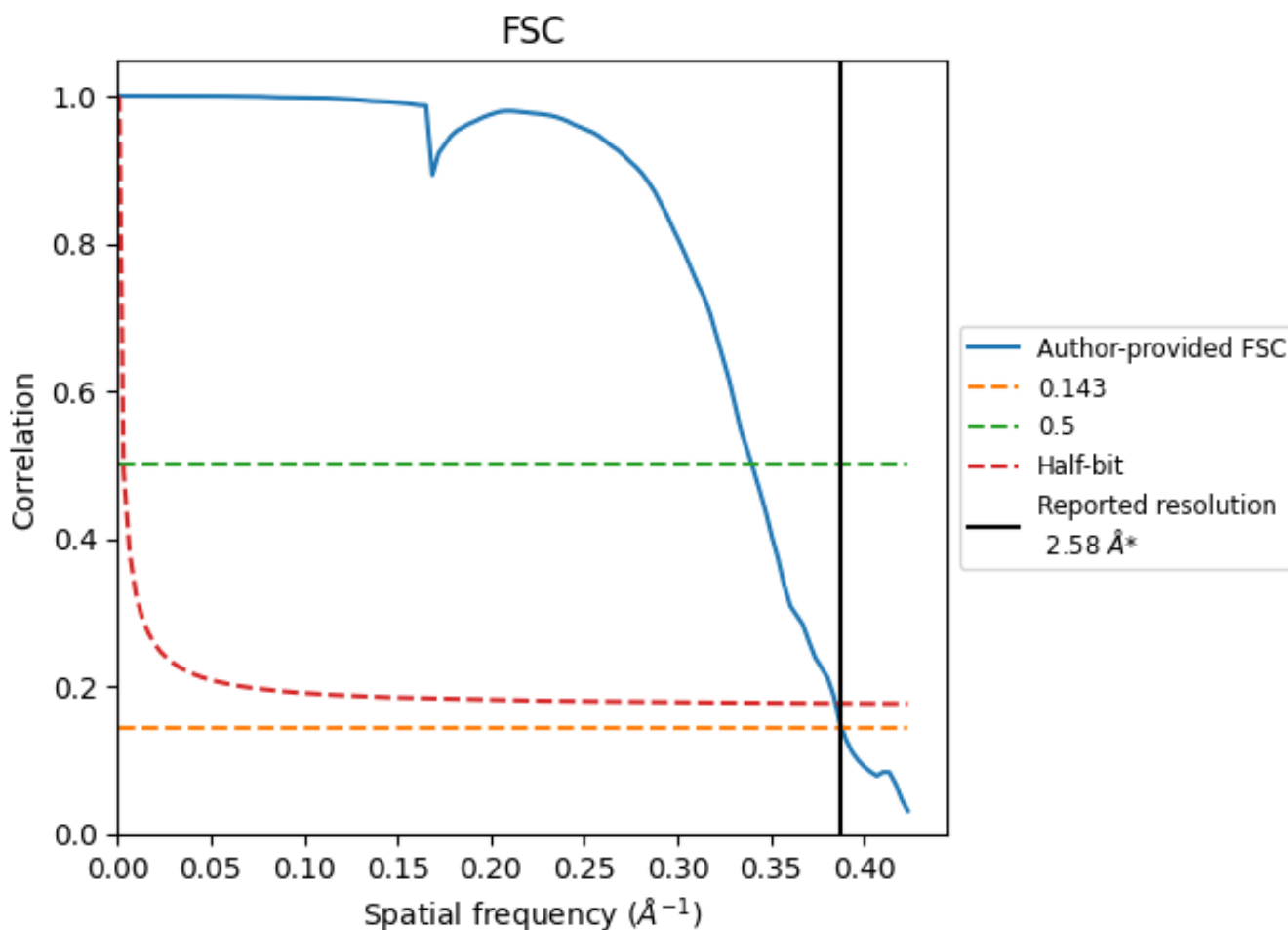

*Reported resolution corresponds to spatial frequency of 0.388 Å⁻¹

8.2 Resolution estimates [i](#)

Resolution estimate (Å)	Estimation criterion (FSC cut-off)		
	0.143	0.5	Half-bit
Reported by author	2.58	-	-
Author-provided FSC curve	2.58	2.94	2.60
Unmasked-calculated*	-	-	-

*Resolution estimate based on FSC curve calculated by comparison of deposited half-maps.

9 Map-model fit [i](#)

This section contains information regarding the fit between EMDB map EMD-21690 and PDB model 6WJ6. Per-residue inclusion information can be found in section 3 on page 18.

9.1 Map-model overlay [i](#)

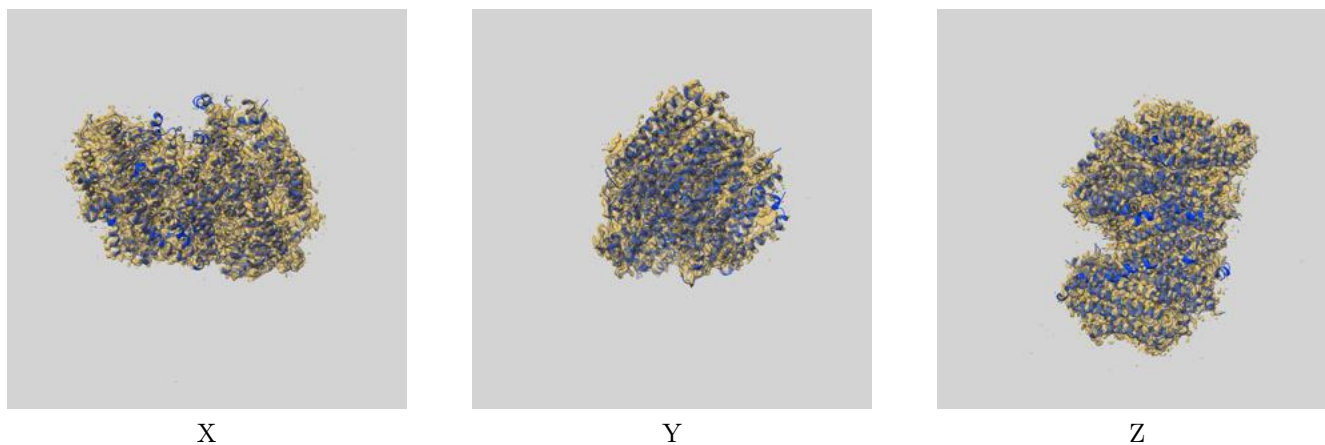

The images above show the 3D surface view of the map at the recommended contour level 0.0394 at 50% transparency in yellow overlaid with a ribbon representation of the model coloured in blue. These images allow for the visual assessment of the quality of fit between the atomic model and the map.

9.2 Q-score mapped to coordinate model [i](#)

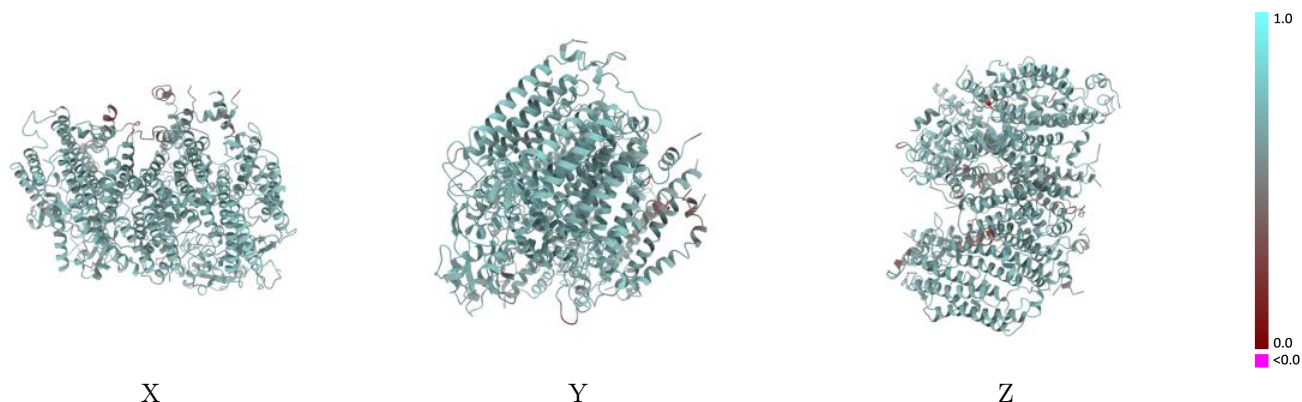

The images above show the model with each residue coloured according to its Q-score. This shows their resolvability in the map with higher Q-score values reflecting better resolvability. Please note: Q-score is calculating the resolvability of atoms, and thus high values are only expected at resolutions at which atoms can be resolved. Low Q-score values may therefore be expected for many entries.

9.3 Atom inclusion mapped to coordinate model [i](#)

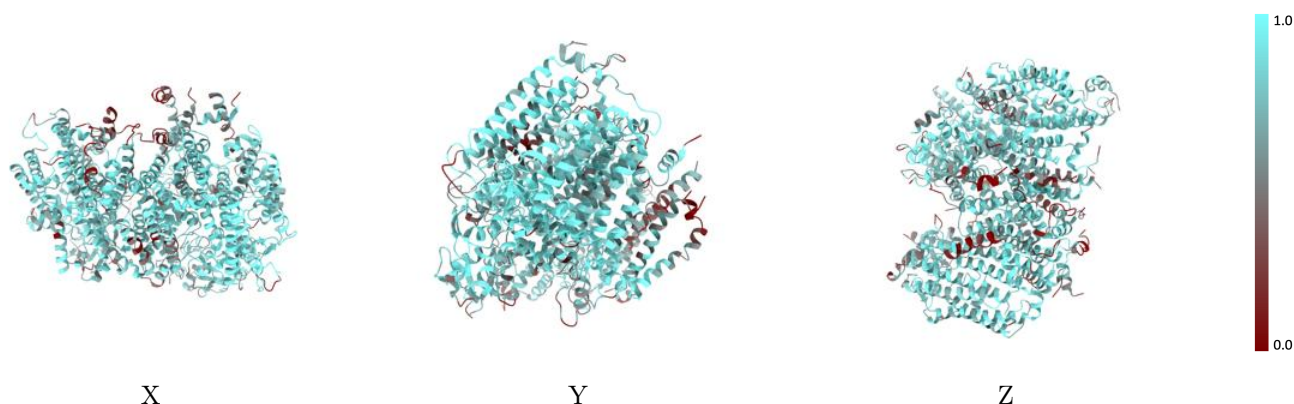

The images above show the model with each residue coloured according to its atom inclusion. This shows to what extent they are inside the map at the recommended contour level (0.0394).



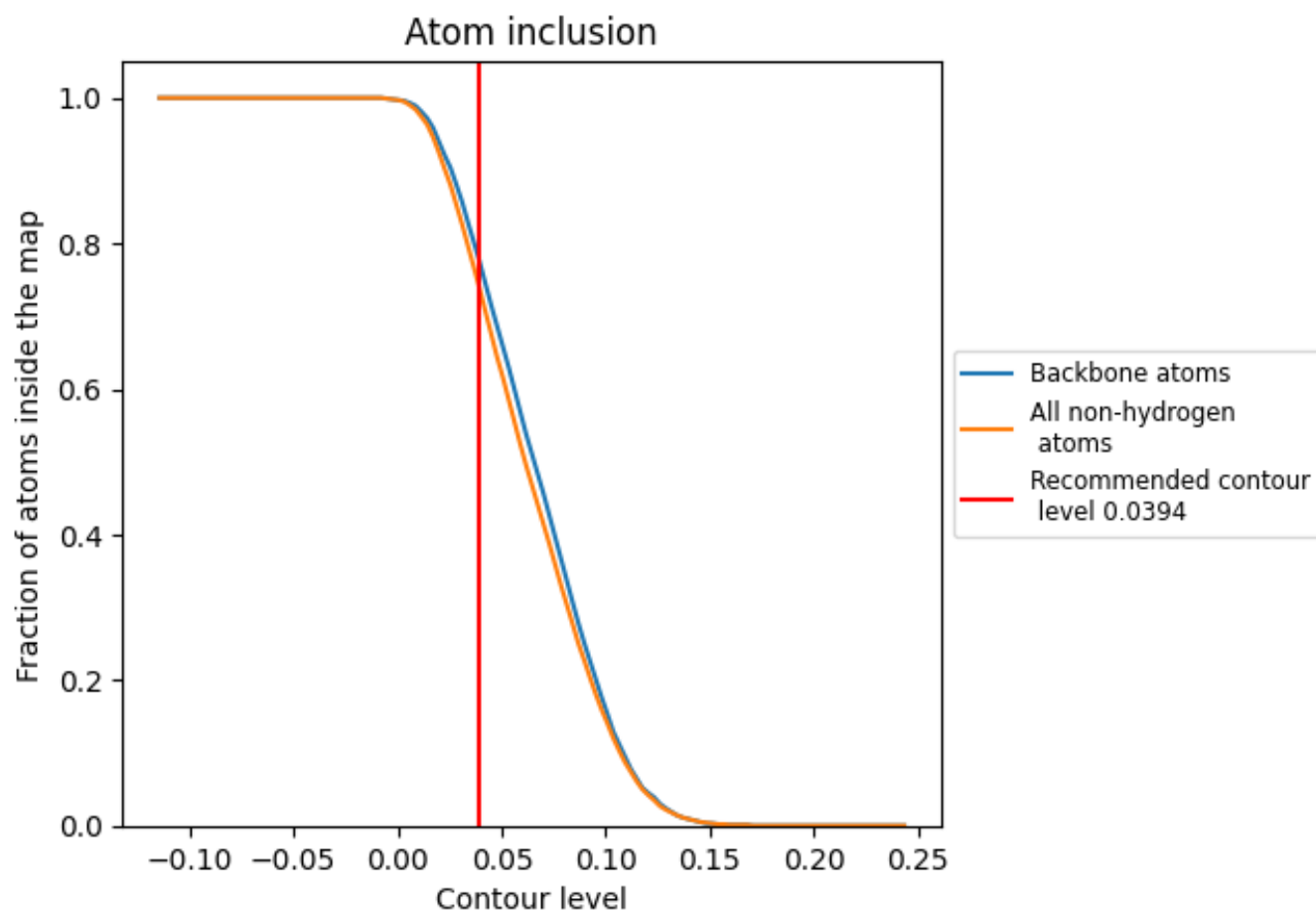

























9.4 Atom inclusion [i](#)



At the recommended contour level, 78% of all backbone atoms, 74% of all non-hydrogen atoms, are inside the map.

9.5 Map-model fit summary [i](#)

The table lists the average atom inclusion at the recommended contour level (0.0394) and Q-score for the entire model and for each chain.

Chain	Atom inclusion	Q-score
All	 0.7390	 0.6280
A	 0.7490	 0.6320
B	 0.8000	 0.6430
C	 0.7270	 0.6230
D	 0.8010	 0.6470
E	 0.6080	 0.5650
F	 0.5880	 0.5810
H	 0.7380	 0.6190
I	 0.6480	 0.6150
K	 0.3260	 0.4860
L	 0.7050	 0.6530
M	 0.5850	 0.6200
T	 0.4160	 0.5800
X	 0.5100	 0.5860

