



Full wwPDB X-ray Structure Validation Report ⓘ

Aug 26, 2023 – 09:34 PM EDT

PDB ID : 3FCS
Title : Structure of complete ectodomain of integrin α IIBb3
Authors : Zhu, J.; Luo, B.-H.; Xiao, T.; Zhang, C.; Nishida, N.; Springer, T.A.
Deposited on : 2008-11-22
Resolution : 2.55 Å(reported)

This is a Full wwPDB X-ray Structure Validation Report for a publicly released PDB entry.

We welcome your comments at validation@mail.wwpdb.org

A user guide is available at

<https://www.wwpdb.org/validation/2017/XrayValidationReportHelp>

with specific help available everywhere you see the ⓘ symbol.

The types of validation reports are described at

<http://www.wwpdb.org/validation/2017/FAQs#types>.

The following versions of software and data (see [references ⓘ](#)) were used in the production of this report:

MolProbity : 4.02b-467
Mogul : 1.8.5 (274361), CSD as541be (2020)
Xtriage (Phenix) : 1.13
EDS : 2.35
Percentile statistics : 20191225.v01 (using entries in the PDB archive December 25th 2019)
Refmac : 5.8.0158
CCP4 : 7.0.044 (Gargrove)
Ideal geometry (proteins) : Engh & Huber (2001)
Ideal geometry (DNA, RNA) : Parkinson et al. (1996)
Validation Pipeline (wwPDB-VP) : 2.35

1 Overall quality at a glance

The following experimental techniques were used to determine the structure:

X-RAY DIFFRACTION

The reported resolution of this entry is 2.55 Å.

Percentile scores (ranging between 0-100) for global validation metrics of the entry are shown in the following graphic. The table shows the number of entries on which the scores are based.

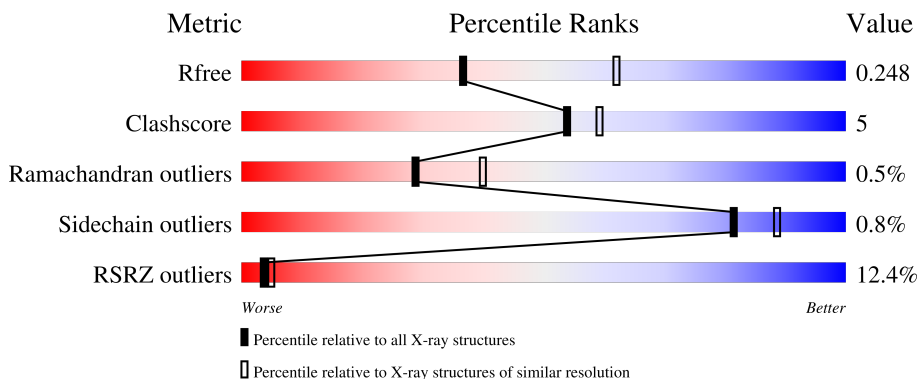





Metric	Whole archive (#Entries)	Similar resolution (#Entries, resolution range(Å))
R_{free}	130704	1284 (2.56-2.52)
Clashscore	141614	1332 (2.56-2.52)
Ramachandran outliers	138981	1315 (2.56-2.52)
Sidechain outliers	138945	1315 (2.56-2.52)
RSRZ outliers	127900	1272 (2.56-2.52)

The table below summarises the geometric issues observed across the polymeric chains and their fit to the electron density. The red, orange, yellow and green segments of the lower bar indicate the fraction of residues that contain outliers for ≥ 3 , 2, 1 and 0 types of geometric quality criteria respectively. A grey segment represents the fraction of residues that are not modelled. The numeric value for each fraction is indicated below the corresponding segment, with a dot representing fractions $\leq 5\%$. The upper red bar (where present) indicates the fraction of residues that have poor fit to the electron density. The numeric value is given above the bar.

Mol	Chain	Length	Quality of chain
1	A	959	
1	C	959	
2	B	690	
2	D	690	
3	E	2	

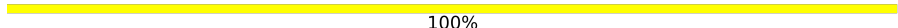
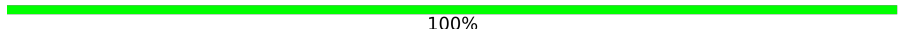
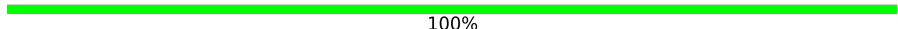
Continued on next page...

Continued from previous page...

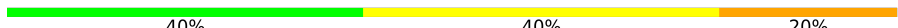
Mol	Chain	Length	Quality of chain
3	H	2	 100%
3	J	2	 100%
3	K	2	 100%
3	L	2	 100%
3	M	2	 50% 50%
3	N	2	 50% 50%
4	F	4	 50% 50%
5	G	3	 67% 33%
6	I	5	 40% 40% 20%

The following table lists non-polymeric compounds, carbohydrate monomers and non-standard residues in protein, DNA, RNA chains that are outliers for geometric or electron-density-fit criteria:

Mol	Type	Chain	Res	Chirality	Geometry	Clashes	Electron density
3	NAG	E	2	-	-	-	X
3	NAG	H	2	-	-	-	X
3	NAG	J	2	-	-	-	X
4	MAN	F	3	X	-	-	-
5	MAN	G	3	X	-	-	-
6	MAN	I	3	X	-	-	-
8	NAG	C	3570	X	-	-	-
8	NAG	D	3099	X	-	-	-

2 Entry composition i

There are 11 unique types of molecules in this entry. The entry contains 24961 atoms, of which 0 are hydrogens and 0 are deuteriums.

In the tables below, the ZeroOcc column contains the number of atoms modelled with zero occupancy, the AltConf column contains the number of residues with at least one atom in alternate conformation and the Trace column contains the number of residues modelled with at most 2 atoms.

- Molecule 1 is a protein called Integrin, alpha 2b.

Mol	Chain	Residues	Atoms					ZeroOcc	AltConf	Trace
			Total	C	N	O	S			
1	A	914	7033	4446	1231	1326	30	0	7	3
1	C	904	6953	4387	1224	1312	30	0	8	2

There are 2 discrepancies between the modelled and reference sequences:

Chain	Residue	Modelled	Actual	Comment	Reference
A	959	CYS	-	expression tag	UNP Q17R67
C	959	CYS	-	expression tag	UNP Q17R67

- Molecule 2 is a protein called Integrin beta-3.

Mol	Chain	Residues	Atoms					ZeroOcc	AltConf	Trace
			Total	C	N	O	S			
2	B	680	5220	3207	890	1052	71	0	1	0
2	D	603	4615	2839	790	923	63	0	3	0

There are 2 discrepancies between the modelled and reference sequences:

Chain	Residue	Modelled	Actual	Comment	Reference
B	688	CYS	PRO	engineered mutation	UNP P05106
D	688	CYS	PRO	engineered mutation	UNP P05106

- Molecule 3 is an oligosaccharide called 2-acetamido-2-deoxy-beta-D-glucopyranose-(1-4)-2-acetamido-2-deoxy-beta-D-glucopyranose.



Mol	Chain	Residues	Atoms				ZeroOcc	AltConf	Trace
3	E	2	Total	C	N	O	0	0	0
			28	16	2	10			
3	H	2	Total	C	N	O	0	0	0
			28	16	2	10			
3	J	2	Total	C	N	O	0	0	0
			28	16	2	10			
3	K	2	Total	C	N	O	0	0	0
			28	16	2	10			
3	L	2	Total	C	N	O	0	0	0
			28	16	2	10			
3	M	2	Total	C	N	O	0	0	0
			28	16	2	10			
3	N	2	Total	C	N	O	0	0	0
			28	16	2	10			

- Molecule 4 is an oligosaccharide called alpha-D-mannopyranose-(1-3)-alpha-D-mannopyranose-(1-4)-2-acetamido-2-deoxy-beta-D-glucopyranose-(1-4)-2-acetamido-2-deoxy-beta-D-glucopyranose.



Mol	Chain	Residues	Atoms				ZeroOcc	AltConf	Trace
4	F	4	Total	C	N	O	0	0	0
			50	28	2	20			

- Molecule 5 is an oligosaccharide called alpha-D-mannopyranose-(1-4)-2-acetamido-2-deoxy-beta-D-glucopyranose-(1-4)-2-acetamido-2-deoxy-beta-D-glucopyranose.

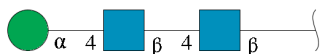

Mol	Chain	Residues	Atoms				ZeroOcc	AltConf	Trace
5	G	3	Total	C	N	O	0	0	0
			39	22	2	15			

- Molecule 6 is an oligosaccharide called alpha-D-mannopyranose-(1-2)-alpha-D-mannopyranose-(1-3)-alpha-D-mannopyranose-(1-4)-2-acetamido-2-deoxy-beta-D-glucopyranose-(1-4)-2-acetamido-2-deoxy-beta-D-glucopyranose.

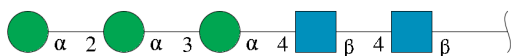

Mol	Chain	Residues	Atoms				ZeroOcc	AltConf	Trace
			Total	C	N	O			
6	I	5	61	34	2	25	0	0	0

- Molecule 7 is CALCIUM ION (three-letter code: CA) (formula: Ca).

Mol	Chain	Residues	Atoms		ZeroOcc	AltConf
7	A	5	Total	Ca	0	0
			5	5		
7	B	2	Total	Ca	0	0
			2	2		
7	C	5	Total	Ca	0	0
			5	5		
7	D	2	Total	Ca	0	0
			2	2		

- Molecule 8 is 2-acetamido-2-deoxy-beta-D-glucopyranose (three-letter code: NAG) (formula: C₈H₁₅NO₆).

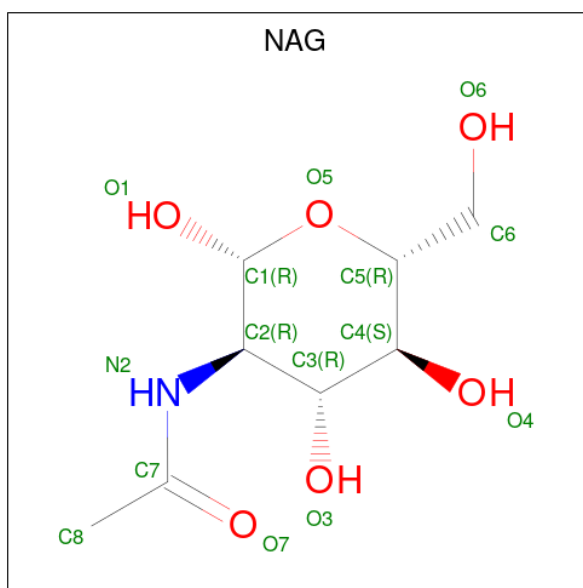

Mol	Chain	Residues	Atoms				ZeroOcc	AltConf
8	A	1	Total	C	N	O	0	0
			14	8	1	5		
8	A	1	Total	C	N	O	0	0
			14	8	1	5		

Continued on next page...

Continued from previous page...

Mol	Chain	Residues	Atoms				ZeroOcc	AltConf
8	C	1	Total	C	N	O	0	0
			14	8	1	5		
8	C	1	Total	C	N	O	0	0
			14	8	1	5		
8	D	1	Total	C	N	O	0	0
			14	8	1	5		

- Molecule 9 is IMIDAZOLE (three-letter code: IMD) (formula: $C_3H_5N_2$).

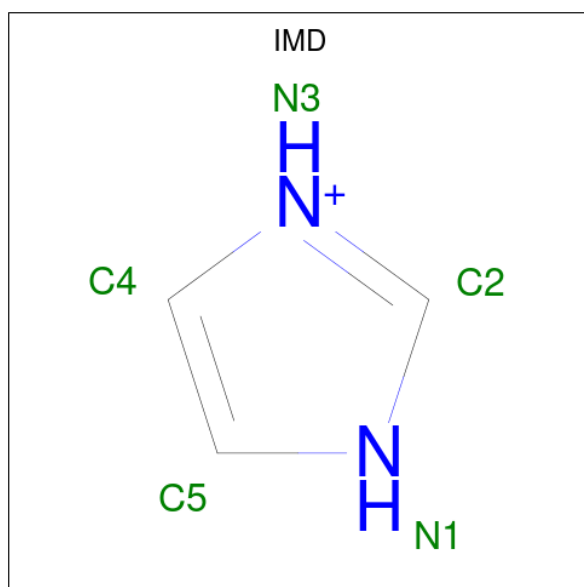

Mol	Chain	Residues	Atoms			ZeroOcc	AltConf
9	A	1	Total	C	N	0	0
			5	3	2		
9	C	1	Total	C	N	0	0
			5	3	2		
9	C	1	Total	C	N	0	0
			5	3	2		
9	C	1	Total	C	N	0	0
			5	3	2		
9	C	1	Total	C	N	0	0
			5	3	2		

- Molecule 10 is MAGNESIUM ION (three-letter code: MG) (formula: Mg).

Mol	Chain	Residues	Atoms	ZeroOcc	AltConf
10	B	1	Total Mg 1 1	0	0
10	D	1	Total Mg 1 1	0	0

- Molecule 11 is water.

Mol	Chain	Residues	Atoms	ZeroOcc	AltConf
11	A	232	Total O 232 232	0	0
11	B	73	Total O 73 73	0	0
11	C	270	Total O 270 270	0	0
11	D	103	Total O 103 103	0	0

3 Residue-property plots i

These plots are drawn for all protein, RNA, DNA and oligosaccharide chains in the entry. The first graphic for a chain summarises the proportions of the various outlier classes displayed in the second graphic. The second graphic shows the sequence view annotated by issues in geometry and electron density. Residues are color-coded according to the number of geometric quality criteria for which they contain at least one outlier: green = 0, yellow = 1, orange = 2 and red = 3 or more. A red dot above a residue indicates a poor fit to the electron density ($RSRZ > 2$). Stretches of 2 or more consecutive residues without any outlier are shown as a green connector. Residues present in the sample, but not in the model, are shown in grey.

- Molecule 1: Integrin, alpha 2b

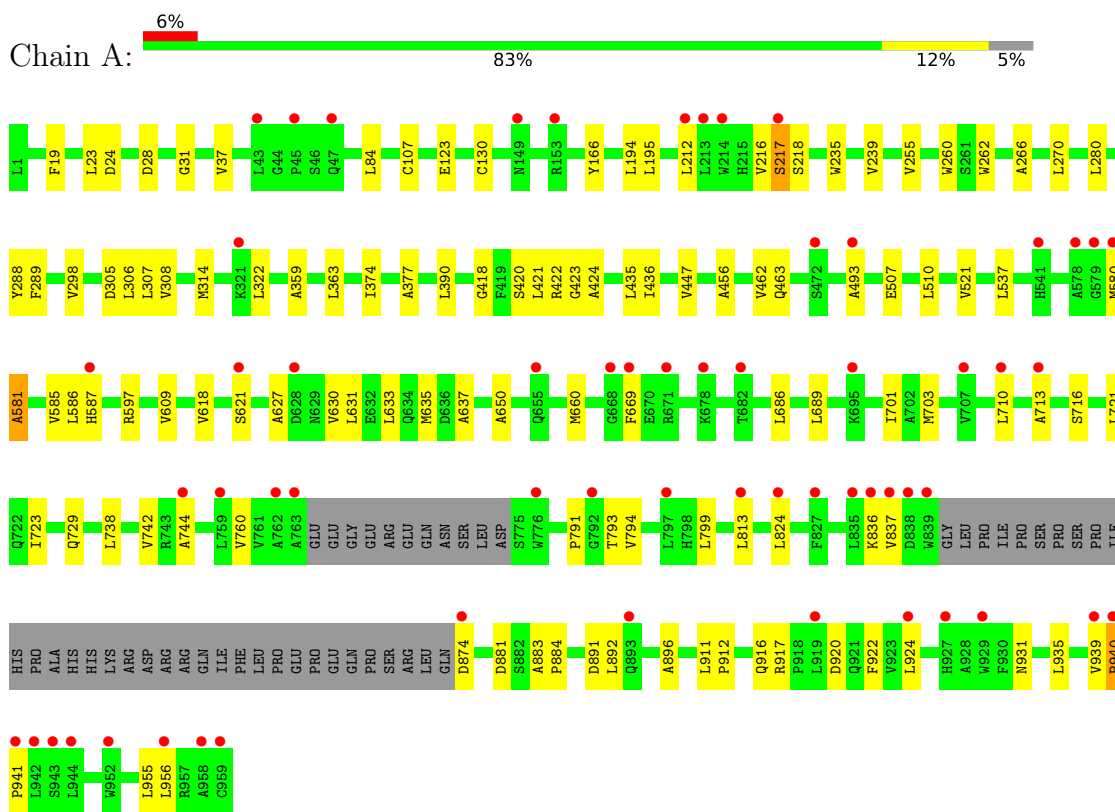

- Molecule 1: Integrin, alpha 2b

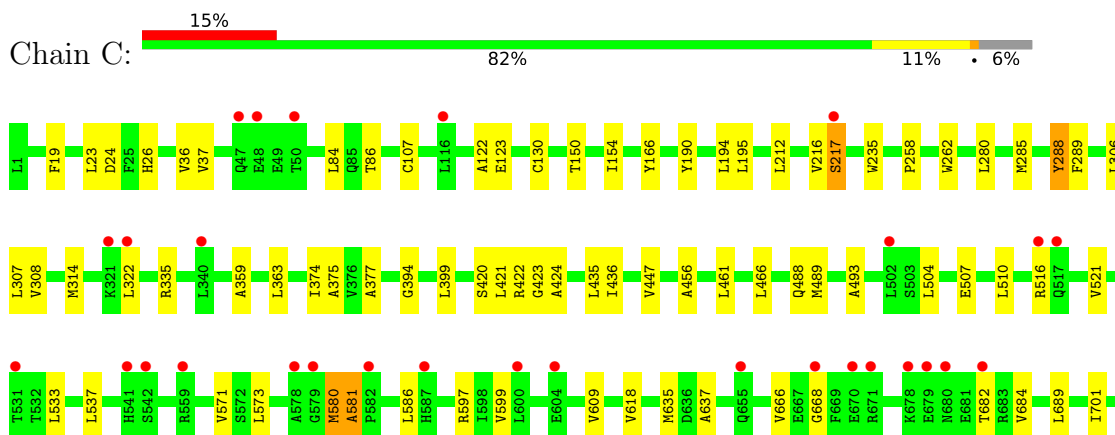

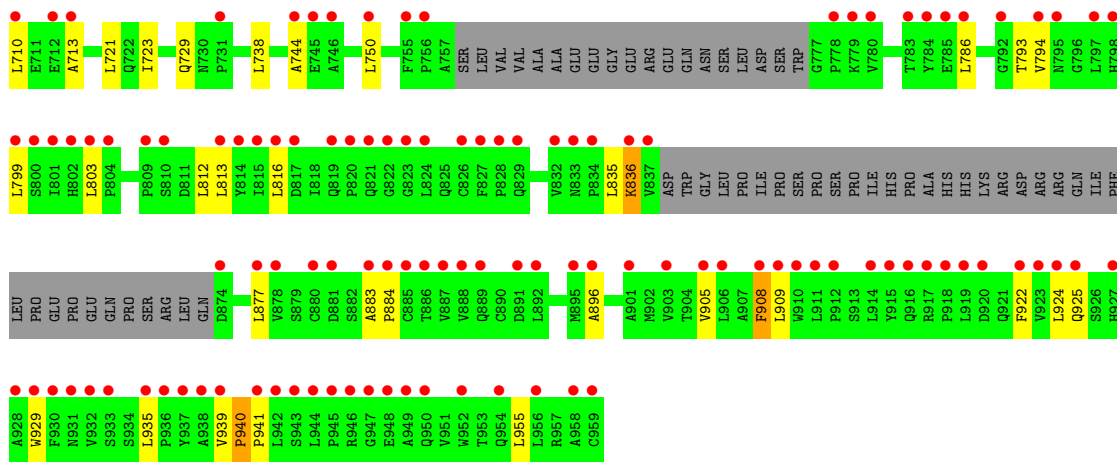

● Molecule 2: Integrin beta-3

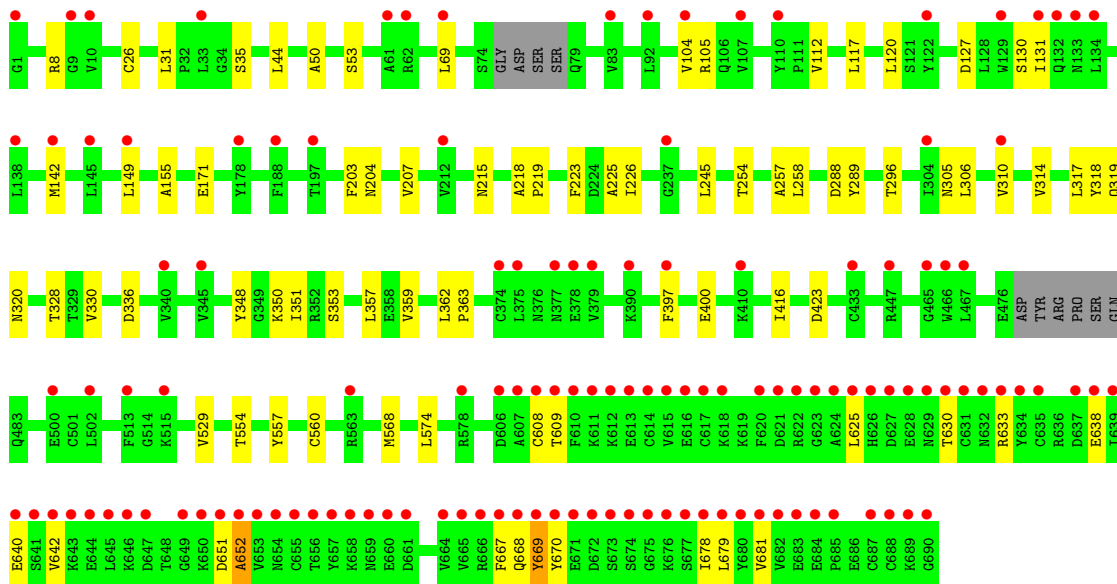
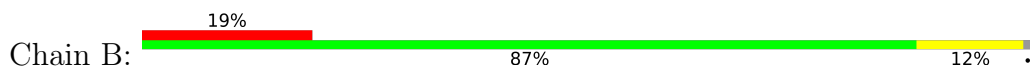

● Molecule 2: Integrin beta-3

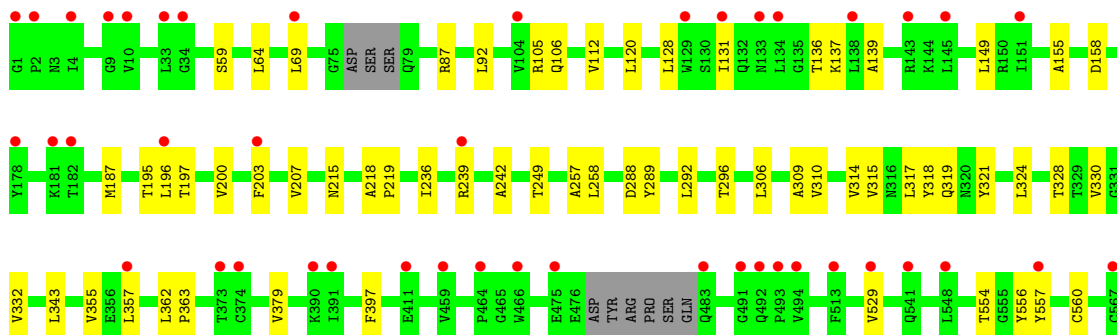
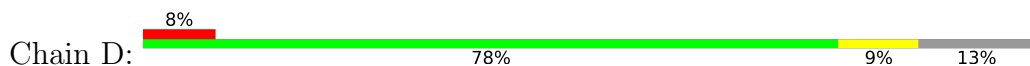

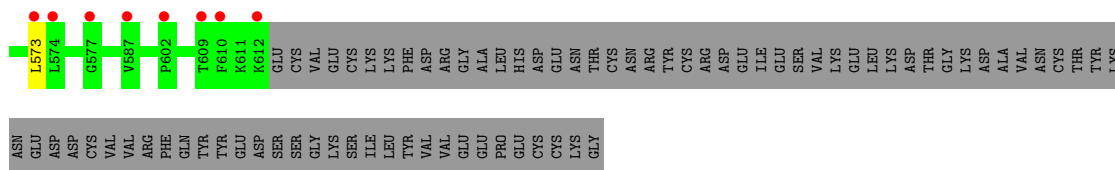

- Molecule 3: 2-acetamido-2-deoxy-beta-D-glucopyranose-(1-4)-2-acetamido-2-deoxy-beta-D-glucopyranose

Chain E: 50% 50%

MAG1
MAG2

- Molecule 3: 2-acetamido-2-deoxy-beta-D-glucopyranose-(1-4)-2-acetamido-2-deoxy-beta-D-glucopyranose

Chain H: 100%

MAG1
MAG2

- Molecule 3: 2-acetamido-2-deoxy-beta-D-glucopyranose-(1-4)-2-acetamido-2-deoxy-beta-D-glucopyranose

Chain J: 100%

MAG1
MAG2

- Molecule 3: 2-acetamido-2-deoxy-beta-D-glucopyranose-(1-4)-2-acetamido-2-deoxy-beta-D-glucopyranose

Chain K: 100%

MAG1
MAG2

- Molecule 3: 2-acetamido-2-deoxy-beta-D-glucopyranose-(1-4)-2-acetamido-2-deoxy-beta-D-glucopyranose

Chain L: 100%

MAG1
MAG2

- Molecule 3: 2-acetamido-2-deoxy-beta-D-glucopyranose-(1-4)-2-acetamido-2-deoxy-beta-D-glucopyranose

Chain M: 50% 50%



- Molecule 3: 2-acetamido-2-deoxy-beta-D-glucopyranose-(1-4)-2-acetamido-2-deoxy-beta-D-glucopyranose

Chain N: 50% 50%



- Molecule 4: alpha-D-mannopyranose-(1-3)-alpha-D-mannopyranose-(1-4)-2-acetamido-2-deoxy-beta-D-glucopyranose-(1-4)-2-acetamido-2-deoxy-beta-D-glucopyranose

Chain F: 50% 50%



- Molecule 5: alpha-D-mannopyranose-(1-4)-2-acetamido-2-deoxy-beta-D-glucopyranose-(1-4)-2-acetamido-2-deoxy-beta-D-glucopyranose

Chain G: 67% 33%



- Molecule 6: alpha-D-mannopyranose-(1-2)-alpha-D-mannopyranose-(1-3)-alpha-D-mannopyranose-(1-4)-2-acetamido-2-deoxy-beta-D-glucopyranose-(1-4)-2-acetamido-2-deoxy-beta-D-glucopyranose

Chain I: 40% 40% 20%



4 Data and refinement statistics

Property	Value	Source
Space group	P 41	Depositor
Cell constants a, b, c, α , β , γ	81.30Å 81.30Å 654.62Å 90.00° 90.00° 90.00°	Depositor
Resolution (Å)	45.31 – 2.55 45.30 – 2.55	Depositor EDS
% Data completeness (in resolution range)	99.9 (45.31-2.55) 98.6 (45.30-2.55)	Depositor EDS
R_{merge}	0.07	Depositor
R_{sym}	0.07	Depositor
$\langle I/\sigma(I) \rangle$ ¹	1.47 (at 2.54Å)	Xtrriage
Refinement program	REFMAC 5.4.0066	Depositor
R, R_{free}	0.233 , 0.268 0.226 , 0.248	Depositor DCC
R_{free} test set	1785 reflections (1.32%)	wwPDB-VP
Wilson B-factor (Å ²)	49.7	Xtrriage
Anisotropy	0.133	Xtrriage
Bulk solvent k_{sol} (e/Å ³), B_{sol} (Å ²)	0.30 , 37.1	EDS
L-test for twinning ²	$\langle L \rangle = 0.40$, $\langle L^2 \rangle = 0.23$	Xtrriage
Estimated twinning fraction	0.155 for h,-k,-l	Xtrriage
F_o, F_c correlation	0.91	EDS
Total number of atoms	24961	wwPDB-VP
Average B, all atoms (Å ²)	37.0	wwPDB-VP

Xtrriage's analysis on translational NCS is as follows: *The largest off-origin peak in the Patterson function is 2.20% of the height of the origin peak. No significant pseudotranslation is detected.*

¹Intensities estimated from amplitudes.

²Theoretical values of $\langle |L| \rangle$, $\langle L^2 \rangle$ for acentric reflections are 0.5, 0.333 respectively for untwinned datasets, and 0.375, 0.2 for perfectly twinned datasets.

5 Model quality [i](#)

5.1 Standard geometry [i](#)

Bond lengths and bond angles in the following residue types are not validated in this section: IMD, NAG, MG, MAN, CA

The Z score for a bond length (or angle) is the number of standard deviations the observed value is removed from the expected value. A bond length (or angle) with $|Z| > 5$ is considered an outlier worth inspection. RMSZ is the root-mean-square of all Z scores of the bond lengths (or angles).

Mol	Chain	Bond lengths		Bond angles	
		RMSZ	# Z >5	RMSZ	# Z >5
1	A	0.24	0/7209	0.43	0/9823
1	C	0.25	0/7124	0.43	0/9705
2	B	0.23	0/5314	0.40	0/7182
2	D	0.24	0/4704	0.41	0/6362
All	All	0.24	0/24351	0.42	0/33072

There are no bond length outliers.

There are no bond angle outliers.

There are no chirality outliers.

There are no planarity outliers.

5.2 Too-close contacts [i](#)

In the following table, the Non-H and H(model) columns list the number of non-hydrogen atoms and hydrogen atoms in the chain respectively. The H(added) column lists the number of hydrogen atoms added and optimized by MolProbity. The Clashes column lists the number of clashes within the asymmetric unit, whereas Symm-Clashes lists symmetry-related clashes.

Mol	Chain	Non-H	H(model)	H(added)	Clashes	Symm-Clashes
1	A	7033	0	6875	80	0
1	C	6953	0	6797	79	0
2	B	5220	0	4964	53	0
2	D	4615	0	4405	42	0
3	E	28	0	25	1	0
3	H	28	0	25	0	0
3	J	28	0	25	0	0
3	K	28	0	25	0	0
3	L	28	0	25	0	0

Continued on next page...

Continued from previous page...

Mol	Chain	Non-H	H(model)	H(added)	Clashes	Symm-Clashes
3	M	28	0	25	0	0
3	N	28	0	25	0	0
4	F	50	0	43	1	0
5	G	39	0	34	2	0
6	I	61	0	52	4	0
7	A	5	0	0	0	0
7	B	2	0	0	0	0
7	C	5	0	0	0	0
7	D	2	0	0	0	0
8	A	28	0	26	1	0
8	C	28	0	26	2	0
8	D	14	0	13	0	0
9	A	5	0	5	0	0
9	C	25	0	25	0	0
10	B	1	0	0	0	0
10	D	1	0	0	0	0
11	A	232	0	0	3	0
11	B	73	0	0	0	0
11	C	270	0	0	1	0
11	D	103	0	0	3	0
All	All	24961	0	23440	251	0

The all-atom clashscore is defined as the number of clashes found per 1000 atoms (including hydrogen atoms). The all-atom clashscore for this structure is 5.

All (251) close contacts within the same asymmetric unit are listed below, sorted by their clash magnitude.

Atom-1	Atom-2	Interatomic distance (Å)	Clash overlap (Å)
1:C:507:GLU:HB2	8:C:3570:NAG:H82	1.38	1.02
1:C:816:LEU:HD11	1:C:908:PHE:CZ	2.08	0.88
2:D:573:LEU:O	11:D:693:HOH:O	2.05	0.74
2:B:320:ASN:HD22	4:F:1:NAG:H83	1.51	0.73
1:C:314:MET:CE	1:C:322:LEU:HD22	2.20	0.72
1:C:516:ARG:O	11:C:1134:HOH:O	2.08	0.70
1:C:507:GLU:CB	8:C:3570:NAG:H82	2.21	0.68
1:A:195:LEU:HD11	1:A:255:VAL:CG2	2.24	0.67
1:A:618:VAL:HG23	1:A:738:LEU:HD13	1.77	0.67
1:C:580:MET:O	1:C:581:ALA:HB3	1.96	0.66
2:D:310:VAL:HG11	2:D:318:TYR:CD2	2.30	0.66
1:A:580:MET:O	1:A:581:ALA:HB3	1.95	0.65
2:D:319[A]:GLN:HA	2:D:330:VAL:HG21	1.79	0.64

Continued on next page...

Continued from previous page...

Atom-1	Atom-2	Interatomic distance (Å)	Clash overlap (Å)
1:A:216:VAL:O	1:A:218:SER:N	2.31	0.64
2:D:69:LEU:HD13	2:D:105:ARG:HB3	1.79	0.64
2:B:69:LEU:HD13	2:B:105:ARG:HB3	1.80	0.63
2:B:203:PHE:O	2:B:207:VAL:HG13	1.98	0.63
2:D:319[B]:GLN:HA	2:D:330:VAL:HG21	1.81	0.63
1:A:813:LEU:HD11	1:A:924:LEU:CD1	2.29	0.63
1:C:420:SER:C	1:C:421:LEU:HD12	2.20	0.62
2:D:195:THR:O	2:D:197:THR:HG23	2.01	0.61
1:C:813:LEU:HD13	1:C:924:LEU:HD13	1.84	0.60
1:A:420:SER:C	1:A:421:LEU:HD12	2.22	0.60
1:A:813:LEU:HD11	1:A:924:LEU:HD13	1.82	0.60
2:B:120:LEU:HD12	2:B:155:ALA:HB1	1.83	0.60
1:C:618:VAL:HG23	1:C:738:LEU:HD13	1.83	0.59
1:C:744:ALA:HB3	1:C:940:PRO:HB3	1.83	0.59
1:A:195:LEU:HD11	1:A:255:VAL:HG22	1.83	0.59
1:C:909:LEU:HD21	1:C:924:LEU:HD11	1.85	0.59
1:A:580:MET:O	1:A:581:ALA:CB	2.50	0.58
1:A:931:ASN:ND2	11:A:1035:HOH:O	2.35	0.58
2:D:288:ASP:OD1	2:D:289:TYR:N	2.36	0.58
1:A:883:ALA:HB1	1:A:884:PRO:HD2	1.86	0.58
1:C:150:THR:HG23	1:C:154:ILE:HD12	1.86	0.57
2:D:315:VAL:HG21	2:D:332:VAL:HG22	1.87	0.57
2:D:362:LEU:HD12	2:D:363:PRO:HD2	1.85	0.57
1:A:262:TRP:HB3	2:B:317:LEU:HD13	1.87	0.57
1:A:939:VAL:HG12	1:A:941:PRO:HD3	1.86	0.57
1:A:195:LEU:HD12	1:A:235:TRP:CH2	2.40	0.56
1:C:939:VAL:HG12	1:C:941:PRO:HD3	1.87	0.56
1:C:721:LEU:N	1:C:721:LEU:HD12	2.20	0.56
2:B:625:LEU:HD13	2:B:630:THR:O	2.06	0.56
2:D:529:VAL:CG1	2:D:557:TYR:CE1	2.89	0.56
1:A:689:LEU:HD21	1:A:701:ILE:HD11	1.88	0.56
2:B:625:LEU:HD22	2:B:630:THR:HB	1.87	0.55
2:B:400:GLU:HB2	5:G:1:NAG:H83	1.89	0.55
1:A:881:ASP:O	11:A:1183:HOH:O	2.18	0.55
1:C:883:ALA:HB1	1:C:884:PRO:HD2	1.89	0.55
1:A:195:LEU:HD11	1:A:255:VAL:HG21	1.88	0.54
2:D:529:VAL:HG11	2:D:557:TYR:CE1	2.42	0.54
1:A:744:ALA:HB3	1:A:940:PRO:HB3	1.90	0.54
1:C:710:LEU:HD23	1:C:713:ALA:HB2	1.90	0.54
2:B:319:GLN:HA	2:B:330:VAL:HG21	1.89	0.54
1:A:314:MET:CE	1:A:322:LEU:HD22	2.37	0.54

Continued on next page...

Continued from previous page...

Atom-1	Atom-2	Interatomic distance (Å)	Clash overlap (Å)
1:C:289:PHE:CZ	1:C:308:VAL:HG11	2.42	0.54
1:C:580:MET:O	1:C:581:ALA:CB	2.55	0.53
2:B:638:GLU:HB2	2:B:678:ILE:HG23	1.90	0.53
1:C:489:MET:CE	1:C:533:LEU:HD12	2.39	0.52
1:C:793:THR:HG22	1:C:896:ALA:HA	1.90	0.52
1:A:650:ALA:HA	1:A:686:LEU:HD23	1.92	0.52
1:A:760:VAL:HG12	1:A:956:LEU:HB2	1.90	0.52
2:B:305:ASN:HB3	2:B:351:ILE:HD13	1.91	0.52
1:A:510:LEU:HB3	1:A:521:VAL:HG23	1.92	0.52
1:A:618:VAL:CG1	1:A:631:LEU:HD22	2.39	0.52
2:B:630:THR:O	2:B:630:THR:HG22	2.10	0.52
1:C:423:GLY:O	1:C:424:ALA:HB3	2.09	0.52
1:C:510:LEU:HB3	1:C:521:VAL:HG23	1.91	0.52
2:B:131:ILE:CG2	2:B:131:ILE:O	2.58	0.51
2:B:667:PHE:CB	2:B:681:VAL:HG22	2.40	0.51
2:B:669:TYR:HB3	2:B:679:LEU:HD23	1.92	0.51
1:C:635:MET:SD	1:C:721:LEU:HD23	2.50	0.51
1:A:436:ILE:HG22	1:A:447:VAL:HG22	1.92	0.51
1:A:710:LEU:HD23	1:A:713:ALA:HB2	1.91	0.51
2:D:218:ALA:HB3	2:D:219:PRO:HD3	1.93	0.51
1:A:660:MET:CE	6:I:2:NAG:H83	2.40	0.51
1:C:314:MET:HE3	1:C:322:LEU:HD22	1.90	0.51
2:B:117:LEU:CD2	2:B:225:ALA:HB1	2.41	0.51
2:D:343:LEU:HD23	2:D:343:LEU:C	2.31	0.50
1:A:689:LEU:CD2	1:A:701:ILE:HD11	2.42	0.50
1:C:436:ILE:HG22	1:C:447:VAL:HG22	1.92	0.50
1:C:609:VAL:HG22	1:C:729:GLN:HB2	1.94	0.50
1:A:423:GLY:O	1:A:424:ALA:HB3	2.11	0.50
1:A:456:ALA:HB2	1:A:586:LEU:HD11	1.94	0.50
2:D:257:ALA:O	2:D:258:LEU:HB2	2.12	0.50
1:A:359:ALA:CB	1:A:421:LEU:HD13	2.42	0.50
1:A:721:LEU:N	1:A:721:LEU:HD12	2.27	0.50
2:B:310:VAL:HG11	2:B:318:TYR:CD2	2.47	0.50
1:A:322:LEU:HD12	2:B:296:THR:HG21	1.93	0.49
2:B:131:ILE:O	2:B:131:ILE:HG22	2.10	0.49
2:D:314:VAL:HG22	2:D:314:VAL:O	2.12	0.49
2:B:652:ALA:HB3	2:B:668:GLN:NE2	2.27	0.49
2:D:120:LEU:HD12	2:D:155:ALA:HB1	1.93	0.49
2:D:59:SER:HB3	2:D:92:LEU:HD23	1.94	0.49
2:D:529:VAL:HG21	2:D:556:TYR:CE1	2.47	0.49
2:B:26:CYS:SG	2:B:31:LEU:HD12	2.52	0.49

Continued on next page...

Continued from previous page...

Atom-1	Atom-2	Interatomic distance (Å)	Clash overlap (Å)
2:B:306:LEU:HB3	2:B:328:THR:HG22	1.94	0.49
2:D:249:THR:HG22	2:D:309:ALA:HB3	1.95	0.49
1:A:359:ALA:HB3	1:A:377:ALA:HB3	1.94	0.49
1:A:390:LEU:N	1:A:390:LEU:HD12	2.28	0.49
1:A:793:THR:HG23	1:A:896:ALA:HA	1.95	0.49
2:D:158:ASP:HB3	2:D:187:MET:CE	2.43	0.48
2:B:630:THR:HG23	2:B:633:ARG:HD3	1.94	0.48
1:A:635:MET:SD	1:A:721:LEU:HD23	2.53	0.48
1:A:716:SER:HA	1:A:742:VAL:HG23	1.96	0.48
2:D:137:LYS:NZ	11:D:1190:HOH:O	2.45	0.48
1:A:507:GLU:HB2	8:A:3570:NAG:H82	1.96	0.48
1:A:794:VAL:HG12	1:A:935:LEU:CD2	2.44	0.48
1:C:24:ASP:HA	1:C:422:ARG:HG3	1.95	0.48
1:C:19:PHE:CZ	1:C:37:VAL:HG11	2.49	0.48
1:C:195:LEU:CD1	1:C:235:TRP:CZ3	2.97	0.48
1:C:258:PRO:HB2	1:C:288:TYR:CD2	2.49	0.48
1:C:359:ALA:CB	1:C:421:LEU:HD13	2.43	0.48
1:C:750:LEU:HD13	1:C:786:LEU:CD2	2.43	0.48
1:C:394:GLY:HA2	1:C:399:LEU:HD23	1.96	0.48
1:C:504:LEU:HD13	1:C:571:VAL:CG1	2.43	0.47
2:D:64:LEU:HD12	2:D:87:ARG:HG2	1.95	0.47
1:C:86:THR:HG21	1:C:212:LEU:HD22	1.95	0.47
1:C:285:MET:HE2	2:D:321:TYR:CE1	2.49	0.47
1:A:216:VAL:O	1:A:217:SER:C	2.52	0.47
1:C:794:VAL:HG12	1:C:935:LEU:CD2	2.44	0.47
1:C:504:LEU:HD23	1:C:573:LEU:HD23	1.95	0.47
1:A:824:LEU:HD12	1:A:891:ASP:O	2.14	0.47
2:D:239:ARG:HB2	2:D:242:ALA:HB3	1.97	0.47
2:B:257:ALA:O	2:B:258:LEU:HB2	2.15	0.47
1:C:466:LEU:O	1:C:599:VAL:HG23	2.15	0.47
1:C:909:LEU:HD11	1:C:955:LEU:HD22	1.97	0.47
1:C:195:LEU:HD13	1:C:235:TRP:CH2	2.50	0.46
1:C:909:LEU:CD2	1:C:924:LEU:HD11	2.44	0.46
6:I:2:NAG:H4	6:I:3:MAN:H2	1.77	0.46
2:B:218:ALA:HB3	2:B:219:PRO:HD3	1.97	0.46
2:B:529:VAL:HG11	2:B:557:TYR:CE1	2.49	0.46
2:B:203:PHE:CE2	2:B:207:VAL:HG11	2.50	0.46
1:A:883:ALA:HB1	1:A:884:PRO:CD	2.45	0.46
1:C:363:LEU:HD21	1:C:435:LEU:HD13	1.97	0.46
1:C:799:LEU:HD12	1:C:929:TRP:O	2.15	0.46
1:C:922:PHE:HB2	1:C:955:LEU:HD12	1.97	0.46

Continued on next page...

Continued from previous page...

Atom-1	Atom-2	Interatomic distance (Å)	Clash overlap (Å)
2:B:171:GLU:N	2:B:171:GLU:OE1	2.49	0.46
1:C:280:LEU:CD1	1:C:306:LEU:HD23	2.45	0.45
2:D:249:THR:HA	2:D:309:ALA:O	2.16	0.45
1:A:289:PHE:CZ	1:A:308:VAL:HG11	2.52	0.45
1:A:637:ALA:HB1	1:A:723:ILE:HD11	1.99	0.45
2:B:117:LEU:HD21	2:B:225:ALA:HB1	1.99	0.45
1:C:195:LEU:HD13	1:C:235:TRP:CZ3	2.52	0.45
1:A:260:TRP:CE3	1:A:266:ALA:HB2	2.51	0.45
2:D:357:LEU:HD11	2:D:397:PHE:CD2	2.51	0.45
1:A:107:CYS:HA	1:A:130:CYS:HA	1.98	0.45
1:A:493:ALA:HB2	1:A:537:LEU:HD13	1.99	0.45
2:B:359:VAL:HG22	2:B:416:ILE:CD1	2.47	0.45
2:D:292:LEU:HD21	2:D:324:LEU:HD12	1.98	0.45
1:A:307:LEU:HD11	1:A:374:ILE:HG21	1.98	0.45
2:D:379:VAL:O	2:D:379:VAL:HG13	2.17	0.45
1:A:24:ASP:HA	1:A:422:ARG:HG3	1.99	0.45
2:B:667:PHE:HB3	2:B:681:VAL:HG22	1.98	0.45
2:B:568:MET:HB2	2:B:574:LEU:HD23	1.98	0.45
1:A:307:LEU:CD1	1:A:374:ILE:HG21	2.47	0.45
1:A:633:LEU:HD22	1:A:703:MET:CE	2.47	0.45
1:A:920:ASP:OD1	11:A:1153:HOH:O	2.21	0.44
1:C:456:ALA:HB2	1:C:586:LEU:HD11	1.99	0.44
1:C:489:MET:HE2	1:C:533:LEU:HD12	1.98	0.44
1:C:835:LEU:O	1:C:836:LYS:C	2.56	0.44
1:C:363:LEU:HD11	1:C:375:ALA:HB2	1.98	0.44
1:C:377:ALA:HB2	1:C:421:LEU:HD11	1.98	0.44
1:A:363:LEU:HD21	1:A:435:LEU:HD13	1.99	0.44
1:C:359:ALA:HB1	1:C:421:LEU:HD13	1.98	0.44
1:C:803:LEU:CD1	1:C:905:VAL:HG11	2.47	0.44
2:D:529:VAL:HG11	2:D:557:TYR:CZ	2.53	0.44
1:A:195:LEU:HD21	1:A:239:VAL:HG11	1.99	0.44
1:C:461:LEU:HD12	1:C:488:GLN:OE1	2.17	0.44
2:B:50:ALA:HB3	2:B:53:SER:HB3	2.00	0.44
2:B:69:LEU:HD13	2:B:105:ARG:CB	2.45	0.44
1:C:493:ALA:HB2	1:C:537:LEU:HD13	2.00	0.44
1:A:359:ALA:HB3	1:A:421:LEU:HD13	2.00	0.43
1:A:689:LEU:HD12	1:A:723:ILE:HG23	1.99	0.43
2:B:223:PHE:CE1	2:B:254:THR:HG21	2.53	0.43
1:C:216:VAL:O	1:C:217:SER:C	2.56	0.43
2:B:26:CYS:HB2	2:B:44:LEU:HD13	1.99	0.43
1:C:666:VAL:HG12	1:C:668:GLY:CA	2.48	0.43

Continued on next page...

Continued from previous page...

Atom-1	Atom-2	Interatomic distance (Å)	Clash overlap (Å)
1:A:19:PHE:CE1	1:A:37:VAL:HG11	2.53	0.43
2:B:112:VAL:O	2:B:149:LEU:HD12	2.18	0.43
2:B:226:ILE:HD13	2:B:306:LEU:HD21	2.01	0.43
1:A:377:ALA:HB1	1:A:418:GLY:O	2.18	0.43
2:B:554:THR:HG22	2:B:560:CYS:O	2.18	0.43
1:A:922:PHE:HB2	1:A:955:LEU:HD12	2.01	0.43
1:C:504:LEU:HD13	1:C:571:VAL:HG11	1.99	0.43
2:D:139:ALA:HB2	2:D:200:VAL:HG11	2.00	0.43
2:D:136:THR:HG22	2:D:200:VAL:HG23	2.00	0.43
1:A:660:MET:HE2	6:I:2:NAG:H83	2.01	0.43
1:A:813:LEU:HD11	1:A:924:LEU:HD11	2.01	0.43
1:A:824:LEU:HD13	1:A:892:LEU:HB2	2.00	0.43
1:A:916:GLN:O	1:A:917:ARG:HB2	2.19	0.43
1:C:637:ALA:HB1	1:C:723:ILE:HD11	2.01	0.43
1:C:689:LEU:CD2	1:C:701:ILE:HD11	2.49	0.42
1:C:689:LEU:HD21	1:C:701:ILE:HD11	1.99	0.42
1:C:883:ALA:HB1	1:C:884:PRO:CD	2.49	0.42
1:A:194:LEU:HD12	1:A:194:LEU:C	2.39	0.42
1:C:19:PHE:CE1	1:C:37:VAL:HG11	2.53	0.42
1:C:107:CYS:HA	1:C:130:CYS:HA	2.00	0.42
2:B:130:SER:OG	2:B:336:ASP:O	2.30	0.42
2:B:357:LEU:HD11	2:B:397:PHE:CD2	2.54	0.42
1:C:122:ALA:O	1:C:123:GLU:HB2	2.19	0.42
1:A:585:VAL:HG12	1:A:587[A]:HIS:CD2	2.54	0.42
2:B:31:LEU:HD21	2:B:35:SER:HB2	2.02	0.42
2:B:245:LEU:HD11	2:B:348:TYR:CD1	2.54	0.42
2:B:350:LYS:O	2:B:353:SER:HB3	2.18	0.42
1:A:627:ALA:HB2	1:A:791:PRO:HB3	2.02	0.42
2:B:204:ASN:O	2:B:207:VAL:HG22	2.20	0.42
2:D:106:GLN:NE2	2:D:355:VAL:HG22	2.34	0.42
1:A:84:LEU:HB2	1:A:212:LEU:HD12	2.00	0.42
3:E:1:NAG:H81	5:G:1:NAG:H2	2.02	0.42
1:A:618:VAL:HG11	1:A:631:LEU:HD22	2.00	0.42
2:B:142:MET:HB3	2:B:149:LEU:HD22	2.01	0.42
1:C:314:MET:HE1	1:C:322:LEU:HD22	2.01	0.42
2:D:128:LEU:O	2:D:131:ILE:HG22	2.19	0.42
1:C:194:LEU:C	1:C:194:LEU:HD12	2.41	0.42
1:A:794:VAL:HG12	1:A:935:LEU:HD22	2.01	0.42
2:B:314:VAL:HG22	2:B:314:VAL:O	2.18	0.42
1:A:195:LEU:CD1	1:A:255:VAL:HG21	2.49	0.41
1:C:877:LEU:HD11	1:C:925:GLN:OE1	2.20	0.41

Continued on next page...

Continued from previous page...

Atom-1	Atom-2	Interatomic distance (Å)	Clash overlap (Å)
1:A:609:VAL:HG22	1:A:729:GLN:HB2	2.01	0.41
2:B:667:PHE:HB2	2:B:681:VAL:HG22	2.02	0.41
1:C:262:TRP:HB3	2:D:317:LEU:HD13	2.03	0.41
1:C:322:LEU:HD12	2:D:296:THR:HG21	2.02	0.41
2:D:529:VAL:HG12	2:D:557:TYR:CE1	2.55	0.41
2:B:529:VAL:CG1	2:B:557:TYR:CE1	3.03	0.41
2:D:196:LEU:HD13	2:D:236:ILE:O	2.20	0.41
2:D:203:PHE:O	2:D:207:VAL:HG13	2.20	0.41
1:A:195:LEU:HD21	1:A:239:VAL:CG1	2.50	0.41
1:A:911:LEU:HB2	1:A:912:PRO:HD3	2.03	0.41
1:A:462:VAL:HG22	1:A:463:GLN:N	2.35	0.41
2:D:306:LEU:HB3	2:D:328:THR:HG22	2.03	0.41
1:A:28:ASP:OD1	1:A:31:GLY:N	2.54	0.41
1:A:280:LEU:CD1	1:A:306:LEU:HD23	2.51	0.41
2:B:362:LEU:HD12	2:B:363:PRO:HD2	2.02	0.41
1:C:682:THR:O	1:C:684:VAL:HG23	2.21	0.41
1:C:812:LEU:CD2	1:C:909:LEU:HD22	2.51	0.41
1:A:298:VAL:HG22	1:A:305:ASP:OD2	2.21	0.41
1:C:26:HIS:HB2	1:C:36:VAL:HG23	2.03	0.41
1:C:195:LEU:HD12	1:C:235:TRP:CZ3	2.56	0.41
1:C:803:LEU:HD13	1:C:905:VAL:HG11	2.03	0.40
2:D:112:VAL:HG22	11:D:737:HOH:O	2.21	0.40
2:B:104:VAL:HG21	2:B:357:LEU:HD21	2.02	0.40
1:C:359:ALA:HB3	1:C:377:ALA:HB3	2.03	0.40
1:A:630:VAL:HG21	6:I:2:NAG:O3	2.21	0.40
1:A:637:ALA:HB1	1:A:723:ILE:CD1	2.51	0.40
2:B:640:GLU:HG2	2:B:642:VAL:HG13	2.02	0.40
1:C:307:LEU:CD1	1:C:374:ILE:HG21	2.51	0.40
2:B:288:ASP:OD1	2:B:289:TYR:N	2.55	0.40
1:C:84:LEU:HB2	1:C:212:LEU:HD12	2.03	0.40
2:D:112:VAL:O	2:D:149:LEU:HD12	2.21	0.40
2:D:554:THR:HG22	2:D:560:CYS:O	2.20	0.40

There are no symmetry-related clashes.

5.3 Torsion angles [i](#)

5.3.1 Protein backbone [i](#)

In the following table, the Percentiles column shows the percent Ramachandran outliers of the chain as a percentile score with respect to all X-ray entries followed by that with respect to entries

of similar resolution.

The Analysed column shows the number of residues for which the backbone conformation was analysed, and the total number of residues.

Mol	Chain	Analysed	Favoured	Allowed	Outliers	Percentiles	
1	A	913/959 (95%)	864 (95%)	41 (4%)	8 (1%)	17	24
1	C	904/959 (94%)	863 (96%)	37 (4%)	4 (0%)	34	46
2	B	675/690 (98%)	613 (91%)	58 (9%)	4 (1%)	25	34
2	D	600/690 (87%)	559 (93%)	41 (7%)	0	100	100
All	All	3092/3298 (94%)	2899 (94%)	177 (6%)	16 (0%)	29	40

All (16) Ramachandran outliers are listed below:

Mol	Chain	Res	Type
1	A	217	SER
1	A	837	VAL
1	A	940	PRO
1	A	581	ALA
1	A	836	LYS
1	C	217	SER
1	C	836	LYS
1	C	940	PRO
2	B	670	TYR
1	A	669[A]	PHE
1	A	669[B]	PHE
2	B	609	THR
2	B	652	ALA
1	C	581	ALA
1	A	123	GLU
2	B	8	ARG

5.3.2 Protein sidechains [i](#)

In the following table, the Percentiles column shows the percent sidechain outliers of the chain as a percentile score with respect to all X-ray entries followed by that with respect to entries of similar resolution.

The Analysed column shows the number of residues for which the sidechain conformation was analysed, and the total number of residues.

Mol	Chain	Analysed	Rotameric	Outliers	Percentiles	
1	A	762/799 (95%)	755 (99%)	7 (1%)	78	86

Continued on next page...

Continued from previous page...

Mol	Chain	Analysed	Rotameric	Outliers	Percentiles	
1	C	753/799 (94%)	745 (99%)	8 (1%)	73	83
2	B	604/612 (99%)	598 (99%)	6 (1%)	76	84
2	D	534/612 (87%)	533 (100%)	1 (0%)	93	97
All	All	2653/2822 (94%)	2631 (99%)	22 (1%)	81	88

All (22) residues with a non-rotameric sidechain are listed below:

Mol	Chain	Res	Type
1	A	23	LEU
1	A	166	TYR
1	A	270	LEU
1	A	288	TYR
1	A	597	ARG
1	A	621	SER
1	A	874	ASP
2	B	127	ASP
2	B	215	ASN
2	B	423	ASP
2	B	608	CYS
2	B	651	ASP
2	B	669	TYR
1	C	23	LEU
1	C	166	TYR
1	C	190	TYR
1	C	288	TYR
1	C	335	ARG
1	C	580	MET
1	C	597	ARG
1	C	908	PHE
2	D	215	ASN

Sometimes sidechains can be flipped to improve hydrogen bonding and reduce clashes. All (14) such sidechains are listed below:

Mol	Chain	Res	Type
1	A	197	GLN
1	A	534	ASN
1	A	676	GLN
1	A	680	ASN
1	A	795	ASN
1	A	916	GLN

Continued on next page...

Continued from previous page...

Mol	Chain	Res	Type
2	B	106	GLN
2	B	668	GLN
1	C	7	GLN
1	C	197	GLN
1	C	676	GLN
1	C	680	ASN
1	C	921	GLN
2	D	14	GLN

5.3.3 RNA [i](#)

There are no RNA molecules in this entry.

5.4 Non-standard residues in protein, DNA, RNA chains [i](#)

There are no non-standard protein/DNA/RNA residues in this entry.

5.5 Carbohydrates [i](#)

26 monosaccharides are modelled in this entry.

In the following table, the Counts columns list the number of bonds (or angles) for which Mogul statistics could be retrieved, the number of bonds (or angles) that are observed in the model and the number of bonds (or angles) that are defined in the Chemical Component Dictionary. The Link column lists molecule types, if any, to which the group is linked. The Z score for a bond length (or angle) is the number of standard deviations the observed value is removed from the expected value. A bond length (or angle) with $|Z| > 2$ is considered an outlier worth inspection. RMSZ is the root-mean-square of all Z scores of the bond lengths (or angles).

Mol	Type	Chain	Res	Link	Bond lengths			Bond angles		
					Counts	RMSZ	$\# Z > 2$	Counts	RMSZ	$\# Z > 2$
3	NAG	E	1	2,3	14,14,15	0.62	0	17,19,21	1.14	1 (5%)
3	NAG	E	2	3	14,14,15	0.60	0	17,19,21	0.95	1 (5%)
4	NAG	F	1	2,4	14,14,15	0.51	0	17,19,21	0.71	0
4	NAG	F	2	4	14,14,15	0.54	0	17,19,21	0.69	0
4	MAN	F	3	4	11,11,12	0.61	0	15,15,17	0.69	0
4	MAN	F	4	4	11,11,12	0.51	0	15,15,17	2.54	3 (20%)
5	NAG	G	1	2,5	14,14,15	0.64	0	17,19,21	0.68	0
5	NAG	G	2	5	14,14,15	0.52	0	17,19,21	0.82	0
5	MAN	G	3	5	11,11,12	0.64	0	15,15,17	0.61	0
3	NAG	H	1	2,3	14,14,15	0.67	0	17,19,21	0.88	0

Mol	Type	Chain	Res	Link	Bond lengths			Bond angles		
					Counts	RMSZ	# Z > 2	Counts	RMSZ	# Z > 2
3	NAG	H	2	3	14,14,15	0.54	0	17,19,21	0.66	0
6	NAG	I	1	2,6	14,14,15	0.63	0	17,19,21	0.91	1 (5%)
6	NAG	I	2	6	14,14,15	0.47	0	17,19,21	0.94	0
6	MAN	I	3	6	11,11,12	0.56	0	15,15,17	0.95	1 (6%)
6	MAN	I	4	6	11,11,12	0.56	0	15,15,17	0.72	0
6	MAN	I	5	6	11,11,12	0.62	0	15,15,17	0.74	0
3	NAG	J	1	3,1	14,14,15	0.51	0	17,19,21	1.26	2 (11%)
3	NAG	J	2	3	14,14,15	0.65	0	17,19,21	0.89	1 (5%)
3	NAG	K	1	2,3	14,14,15	0.62	0	17,19,21	0.71	0
3	NAG	K	2	3	14,14,15	0.57	0	17,19,21	0.67	0
3	NAG	L	1	2,3	14,14,15	0.55	0	17,19,21	0.63	0
3	NAG	L	2	3	14,14,15	0.53	0	17,19,21	0.63	0
3	NAG	M	1	2,3	14,14,15	0.59	0	17,19,21	0.84	1 (5%)
3	NAG	M	2	3	14,14,15	0.58	0	17,19,21	0.74	0
3	NAG	N	1	2,3	14,14,15	0.56	0	17,19,21	0.81	1 (5%)
3	NAG	N	2	3	14,14,15	0.61	0	17,19,21	0.70	0

In the following table, the Chirals column lists the number of chiral outliers, the number of chiral centers analysed, the number of these observed in the model and the number defined in the Chemical Component Dictionary. Similar counts are reported in the Torsion and Rings columns. '-' means no outliers of that kind were identified.

Mol	Type	Chain	Res	Link	Chirals	Torsions	Rings
3	NAG	E	1	2,3	-	2/6/23/26	0/1/1/1
3	NAG	E	2	3	-	0/6/23/26	0/1/1/1
4	NAG	F	1	2,4	-	2/6/23/26	0/1/1/1
4	NAG	F	2	4	-	0/6/23/26	0/1/1/1
4	MAN	F	3	4	1/1/4/5	0/2/19/22	0/1/1/1
4	MAN	F	4	4	-	2/2/19/22	0/1/1/1
5	NAG	G	1	2,5	-	0/6/23/26	0/1/1/1
5	NAG	G	2	5	-	4/6/23/26	0/1/1/1
5	MAN	G	3	5	1/1/4/5	2/2/19/22	0/1/1/1
3	NAG	H	1	2,3	-	0/6/23/26	0/1/1/1
3	NAG	H	2	3	-	0/6/23/26	0/1/1/1
6	NAG	I	1	2,6	-	2/6/23/26	0/1/1/1
6	NAG	I	2	6	-	0/6/23/26	0/1/1/1
6	MAN	I	3	6	1/1/4/5	2/2/19/22	0/1/1/1
6	MAN	I	4	6	-	0/2/19/22	0/1/1/1
6	MAN	I	5	6	-	2/2/19/22	0/1/1/1

Continued on next page...

Continued from previous page...

Mol	Type	Chain	Res	Link	Chirals	Torsions	Rings
3	NAG	J	1	3,1	-	3/6/23/26	0/1/1/1
3	NAG	J	2	3	-	2/6/23/26	0/1/1/1
3	NAG	K	1	2,3	-	2/6/23/26	0/1/1/1
3	NAG	K	2	3	-	0/6/23/26	0/1/1/1
3	NAG	L	1	2,3	-	0/6/23/26	0/1/1/1
3	NAG	L	2	3	-	2/6/23/26	0/1/1/1
3	NAG	M	1	2,3	-	0/6/23/26	0/1/1/1
3	NAG	M	2	3	-	0/6/23/26	0/1/1/1
3	NAG	N	1	2,3	-	0/6/23/26	0/1/1/1
3	NAG	N	2	3	-	1/6/23/26	0/1/1/1

There are no bond length outliers.

All (12) bond angle outliers are listed below:

Mol	Chain	Res	Type	Atoms	Z	Observed(°)	Ideal(°)
4	F	4	MAN	C1-O5-C5	7.33	122.12	112.19
4	F	4	MAN	C1-C2-C3	4.60	115.33	109.67
4	F	4	MAN	O5-C1-C2	4.16	117.19	110.77
3	E	1	NAG	C4-C3-C2	3.47	116.11	111.02
3	J	1	NAG	O4-C4-C5	3.22	117.29	109.30
3	M	1	NAG	O5-C1-C2	-2.59	107.19	111.29
3	N	1	NAG	O5-C1-C2	-2.50	107.35	111.29
3	J	1	NAG	C1-O5-C5	2.41	115.46	112.19
3	E	2	NAG	C4-C3-C2	2.36	114.48	111.02
6	I	3	MAN	O5-C5-C6	2.33	110.86	107.20
3	J	2	NAG	C4-C3-C2	2.22	114.27	111.02
6	I	1	NAG	C4-C3-C2	2.00	113.95	111.02

All (3) chirality outliers are listed below:

Mol	Chain	Res	Type	Atom
4	F	3	MAN	C1
5	G	3	MAN	C1
6	I	3	MAN	C1

All (28) torsion outliers are listed below:

Mol	Chain	Res	Type	Atoms
3	J	2	NAG	O5-C5-C6-O6
3	J	1	NAG	O5-C5-C6-O6

Continued on next page...

Continued from previous page...

Mol	Chain	Res	Type	Atoms
5	G	3	MAN	O5-C5-C6-O6
5	G	2	NAG	O5-C5-C6-O6
3	J	1	NAG	C4-C5-C6-O6
4	F	4	MAN	O5-C5-C6-O6
6	I	5	MAN	O5-C5-C6-O6
3	E	1	NAG	O5-C5-C6-O6
3	L	2	NAG	O5-C5-C6-O6
3	L	2	NAG	C4-C5-C6-O6
3	J	2	NAG	C4-C5-C6-O6
4	F	1	NAG	C8-C7-N2-C2
4	F	1	NAG	O7-C7-N2-C2
5	G	2	NAG	C8-C7-N2-C2
5	G	2	NAG	O7-C7-N2-C2
3	E	1	NAG	C4-C5-C6-O6
3	K	1	NAG	O5-C5-C6-O6
6	I	3	MAN	O5-C5-C6-O6
6	I	5	MAN	C4-C5-C6-O6
5	G	3	MAN	C4-C5-C6-O6
3	K	1	NAG	C4-C5-C6-O6
3	J	1	NAG	C1-C2-N2-C7
5	G	2	NAG	C4-C5-C6-O6
4	F	4	MAN	C4-C5-C6-O6
6	I	3	MAN	C4-C5-C6-O6
6	I	1	NAG	C4-C5-C6-O6
6	I	1	NAG	O5-C5-C6-O6
3	N	2	NAG	C1-C2-N2-C7

There are no ring outliers.

5 monomers are involved in 7 short contacts:

Mol	Chain	Res	Type	Clashes	Symm-Clashes
5	G	1	NAG	2	0
4	F	1	NAG	1	0
6	I	3	MAN	1	0
6	I	2	NAG	4	0
3	E	1	NAG	1	0

The following is a two-dimensional graphical depiction of Mogul quality analysis of bond lengths, bond angles, torsion angles, and ring geometry for oligosaccharide.

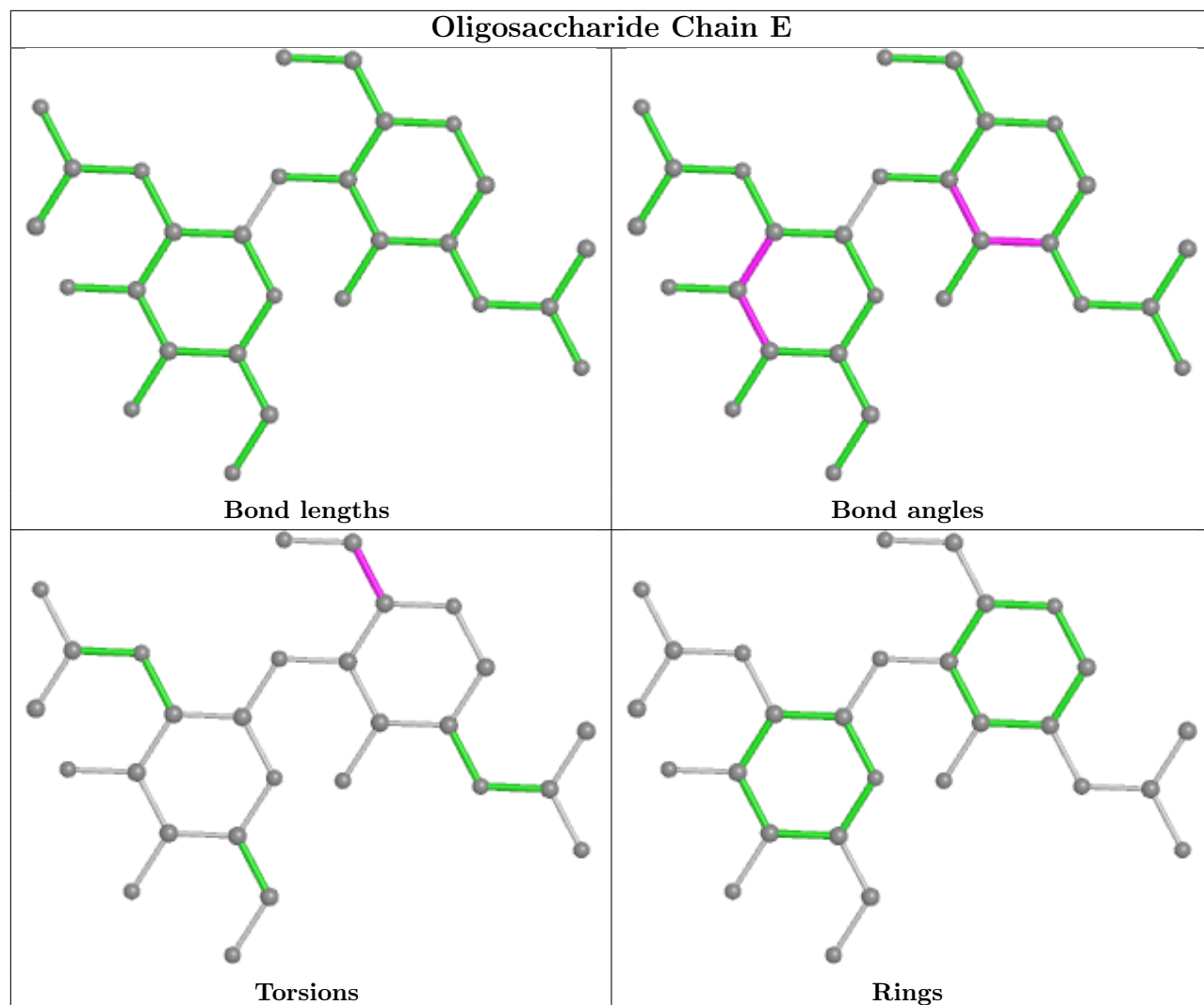

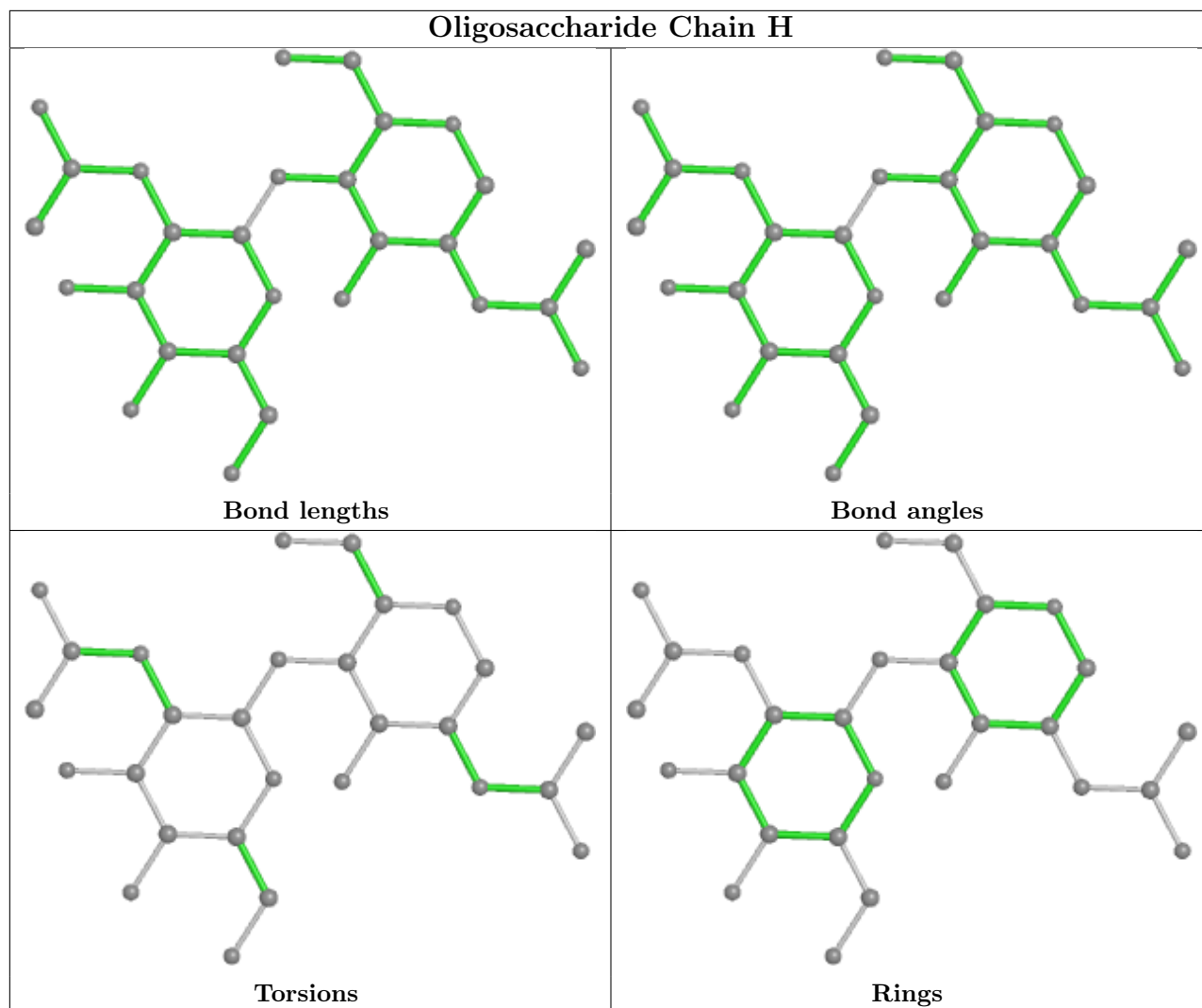

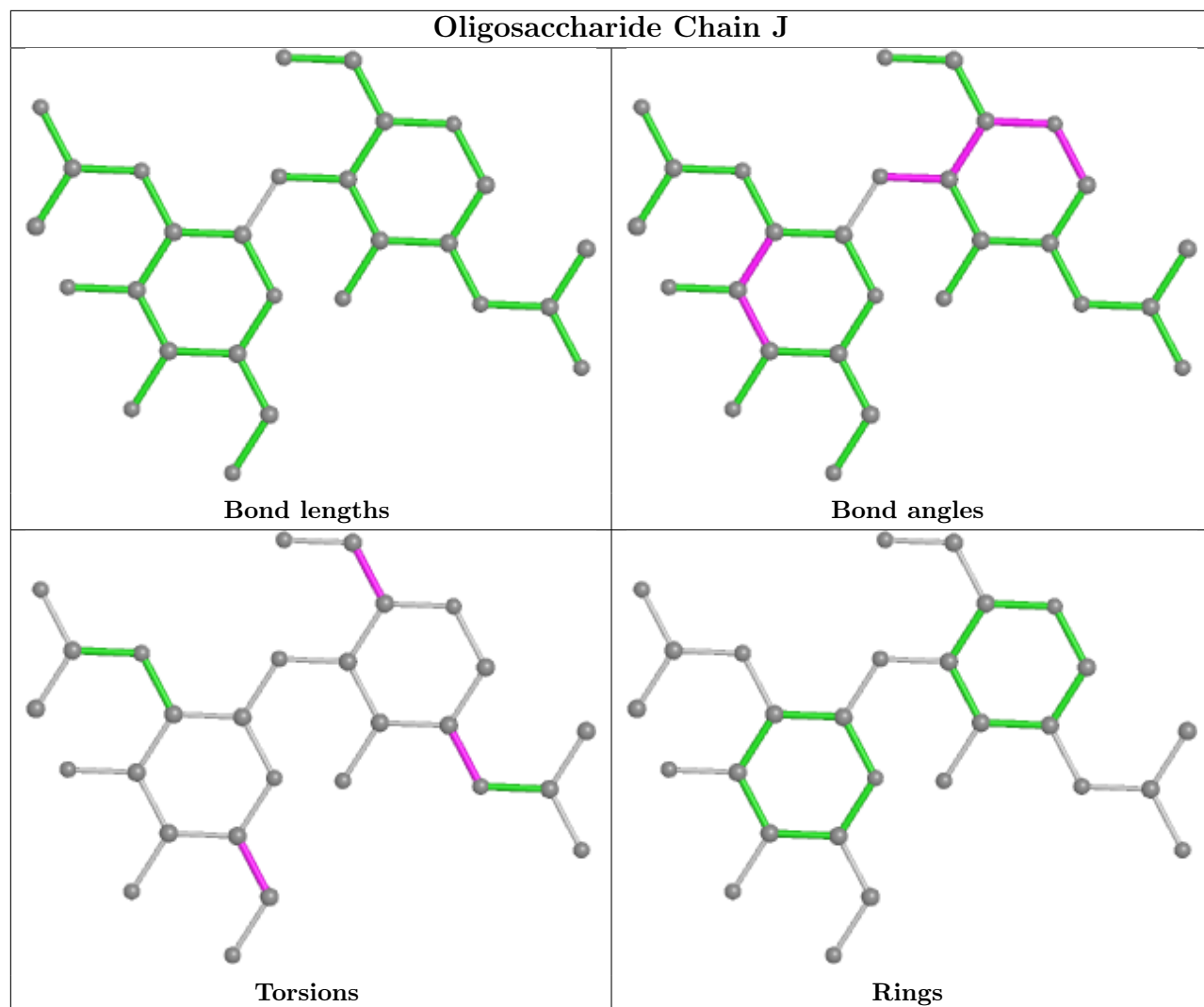

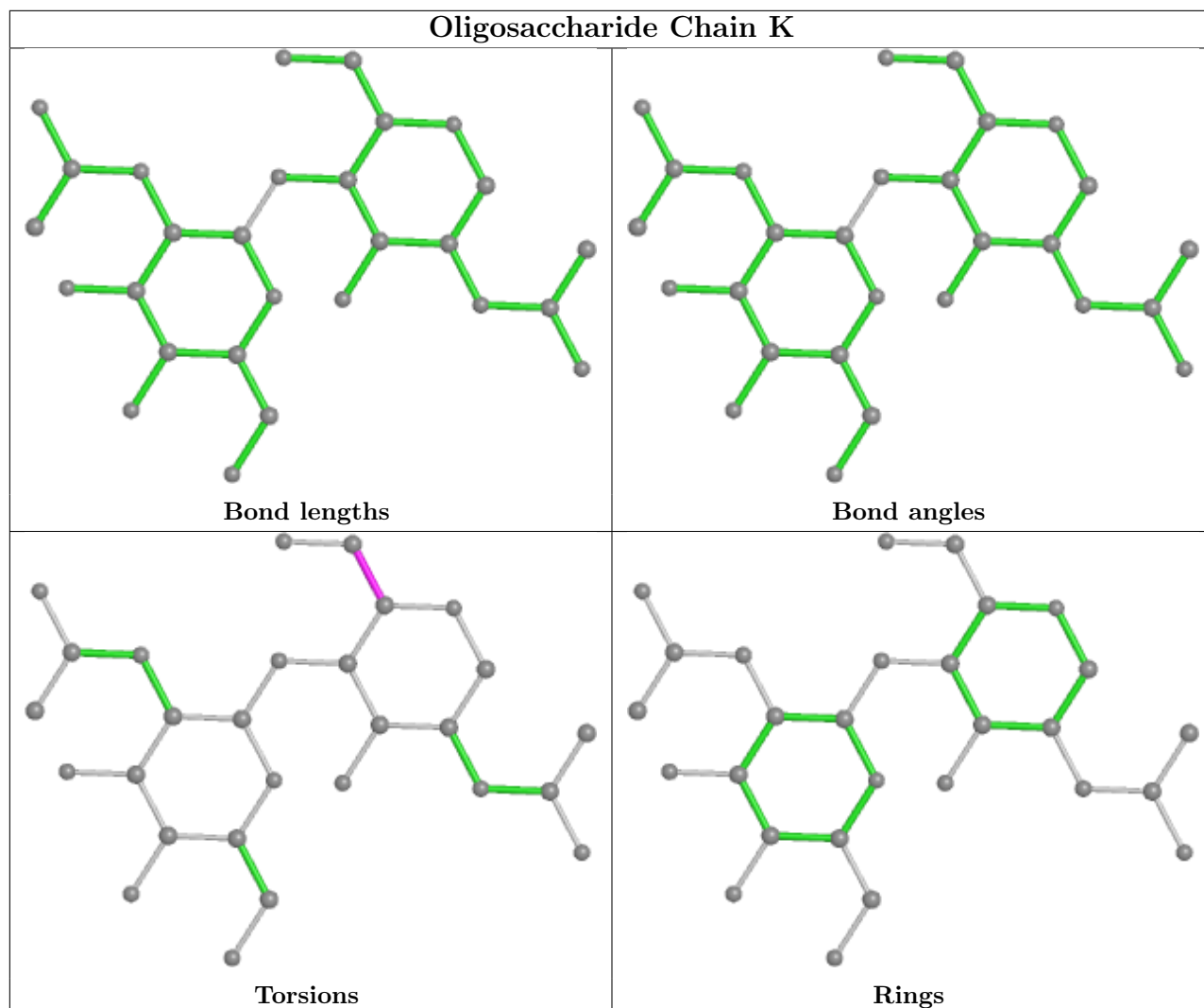

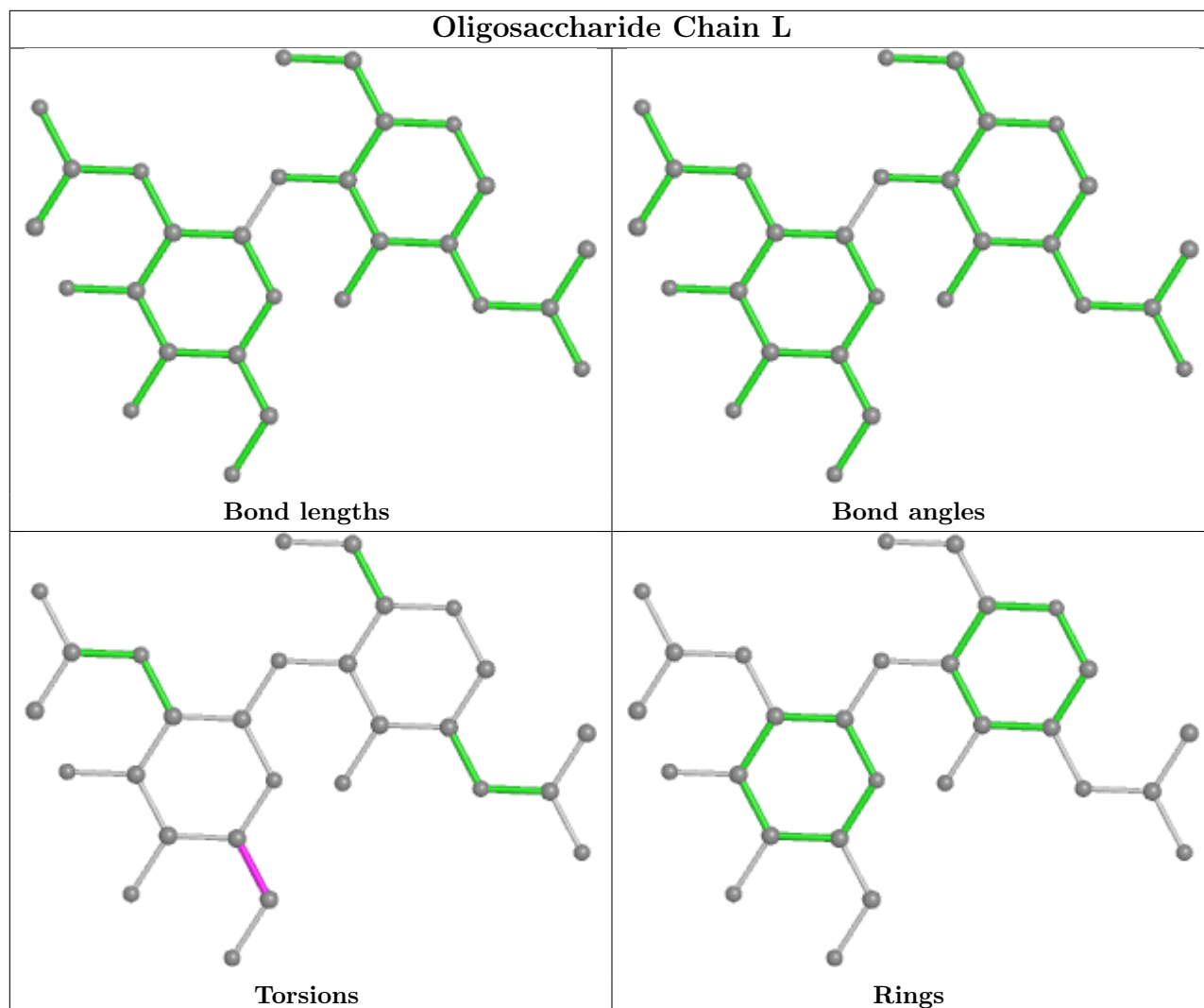

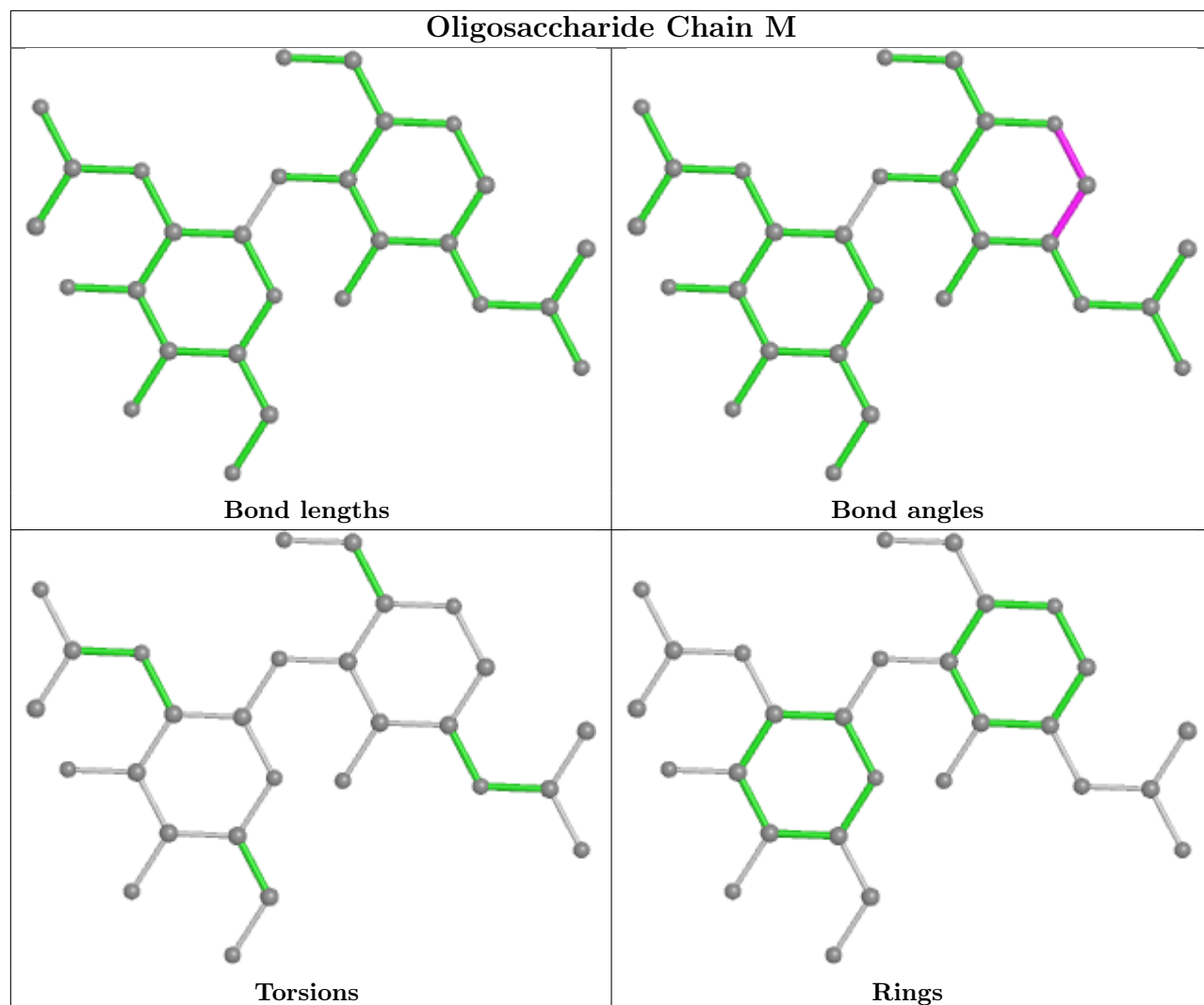

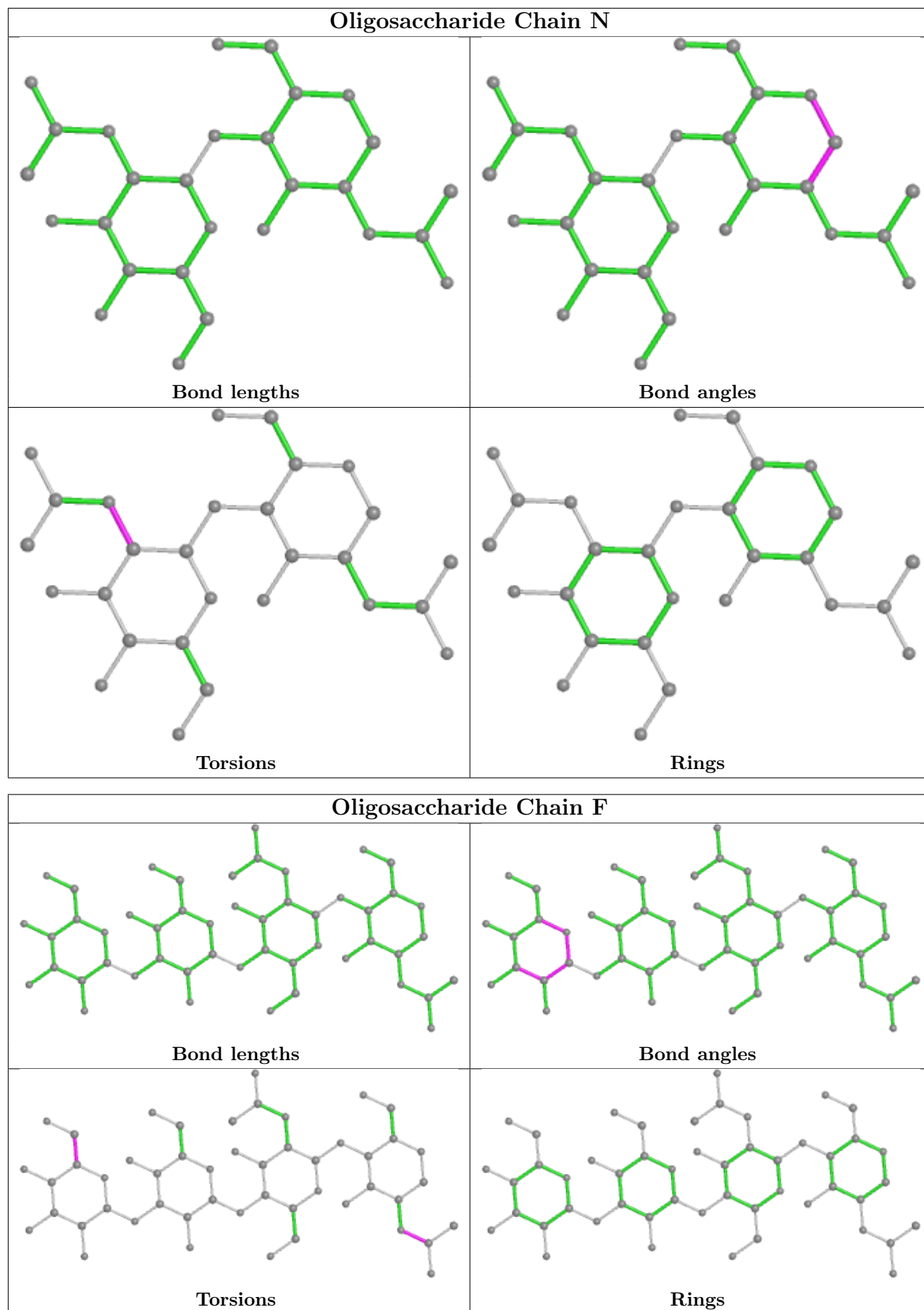

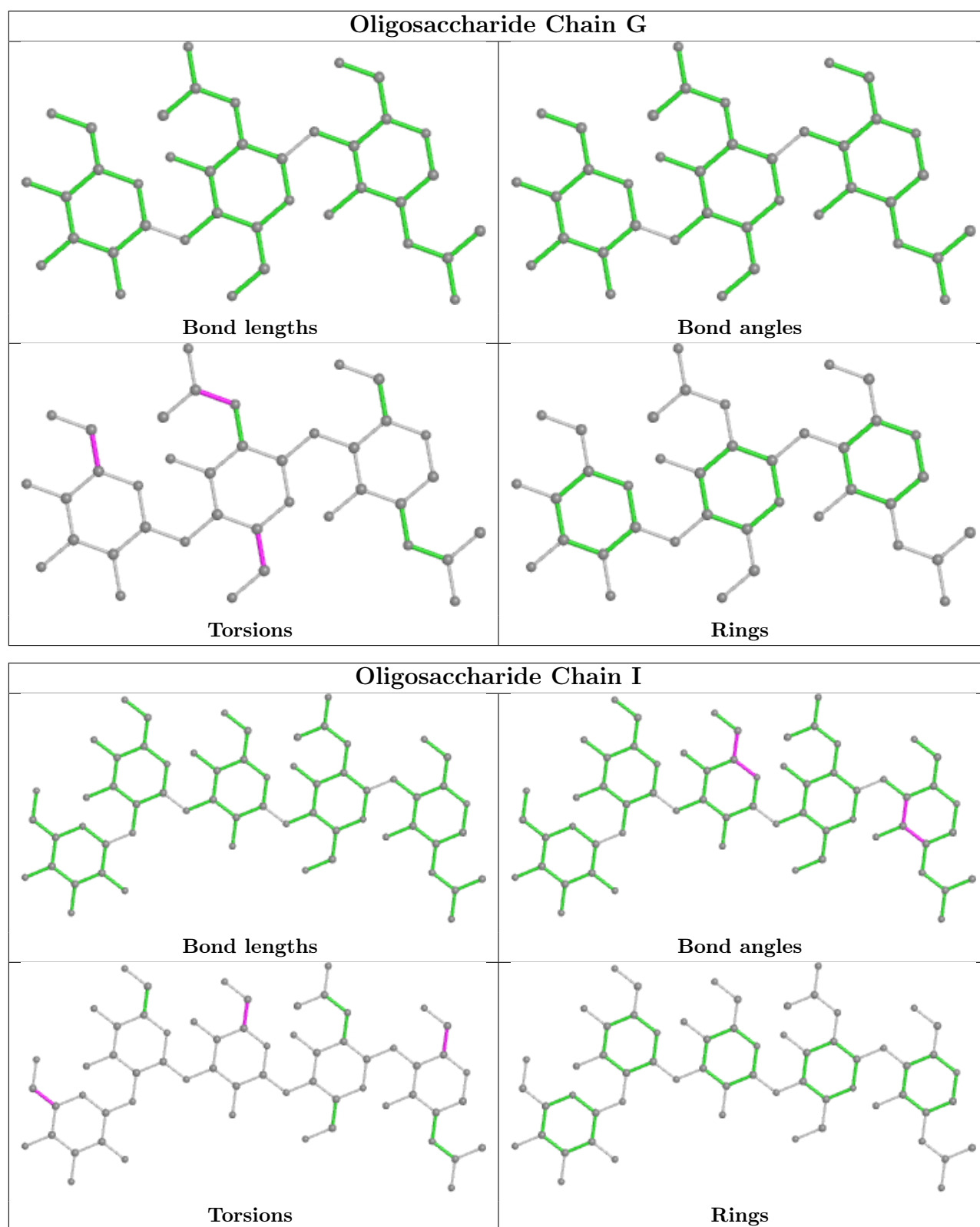

5.6 Ligand geometry [i](#)

Of 27 ligands modelled in this entry, 16 are monoatomic - leaving 11 for Mogul analysis.

In the following table, the Counts columns list the number of bonds (or angles) for which Mogul statistics could be retrieved, the number of bonds (or angles) that are observed in the model and the number of bonds (or angles) that are defined in the Chemical Component Dictionary. The Link column lists molecule types, if any, to which the group is linked. The Z score for a bond length (or angle) is the number of standard deviations the observed value is removed from the expected value. A bond length (or angle) with $|Z| > 2$ is considered an outlier worth inspection. RMSZ is the root-mean-square of all Z scores of the bond lengths (or angles).

Mol	Type	Chain	Res	Link	Bond lengths			Bond angles		
					Counts	RMSZ	# Z > 2	Counts	RMSZ	# Z > 2
8	NAG	D	3099	2	14,14,15	0.57	0	17,19,21	0.67	0
8	NAG	A	3570	1	14,14,15	0.65	0	17,19,21	1.60	2 (11%)
9	IMD	C	5001	-	3,5,5	0.43	0	4,5,5	0.60	0
8	NAG	C	3570	1	14,14,15	0.58	0	17,19,21	0.66	0
9	IMD	C	5004	-	3,5,5	0.42	0	4,5,5	0.58	0
9	IMD	A	5001	-	3,5,5	0.42	0	4,5,5	0.59	0
9	IMD	C	5002	-	3,5,5	0.44	0	4,5,5	0.59	0
8	NAG	C	3015	1	14,14,15	0.58	0	17,19,21	0.85	0
8	NAG	A	3015	1	14,14,15	0.49	0	17,19,21	0.73	0
9	IMD	C	960	-	3,5,5	0.45	0	4,5,5	0.58	0
9	IMD	C	5003	-	3,5,5	0.43	0	4,5,5	0.60	0

In the following table, the Chirals column lists the number of chiral outliers, the number of chiral centers analysed, the number of these observed in the model and the number defined in the Chemical Component Dictionary. Similar counts are reported in the Torsion and Rings columns. '-' means no outliers of that kind were identified.

Mol	Type	Chain	Res	Link	Chirals	Torsions	Rings
8	NAG	D	3099	2	1/1/5/7	0/6/23/26	0/1/1/1
8	NAG	A	3570	1	-	2/6/23/26	0/1/1/1
9	IMD	C	5001	-	-	-	0/1/1/1
8	NAG	C	3570	1	1/1/5/7	1/6/23/26	0/1/1/1
9	IMD	C	5004	-	-	-	0/1/1/1
9	IMD	A	5001	-	-	-	0/1/1/1
9	IMD	C	5002	-	-	-	0/1/1/1
8	NAG	C	3015	1	-	0/6/23/26	0/1/1/1
8	NAG	A	3015	1	-	0/6/23/26	0/1/1/1
9	IMD	C	960	-	-	-	0/1/1/1
9	IMD	C	5003	-	-	-	0/1/1/1

There are no bond length outliers.

All (2) bond angle outliers are listed below:

Mol	Chain	Res	Type	Atoms	Z	Observed(°)	Ideal(°)
8	A	3570	NAG	C1-O5-C5	5.40	119.51	112.19
8	A	3570	NAG	O5-C1-C2	2.72	115.58	111.29

All (2) chirality outliers are listed below:

Mol	Chain	Res	Type	Atom
8	C	3570	NAG	C1
8	D	3099	NAG	C1

All (3) torsion outliers are listed below:

Mol	Chain	Res	Type	Atoms
8	A	3570	NAG	O5-C5-C6-O6
8	A	3570	NAG	C4-C5-C6-O6
8	C	3570	NAG	C3-C2-N2-C7

There are no ring outliers.

2 monomers are involved in 3 short contacts:

Mol	Chain	Res	Type	Clashes	Symm-Clashes
8	A	3570	NAG	1	0
8	C	3570	NAG	2	0

5.7 Other polymers [i](#)

There are no such residues in this entry.

5.8 Polymer linkage issues [i](#)

There are no chain breaks in this entry.

6 Fit of model and data [i](#)

6.1 Protein, DNA and RNA chains [i](#)

In the following table, the column labelled ‘#RSRZ > 2’ contains the number (and percentage) of RSRZ outliers, followed by percent RSRZ outliers for the chain as percentile scores relative to all X-ray entries and entries of similar resolution. The OWAB column contains the minimum, median, 95th percentile and maximum values of the occupancy-weighted average B-factor per residue. The column labelled ‘Q < 0.9’ lists the number of (and percentage) of residues with an average occupancy less than 0.9.

Mol	Chain	Analysed	<RSRZ>	#RSRZ>2	OWAB(Å ²)	Q<0.9
1	A	914/959 (95%)	0.67	60 (6%) 18 21	23, 27, 53, 90	0
1	C	904/959 (94%)	1.11	142 (15%) 2 2	23, 27, 52, 90	16 (1%)
2	B	680/690 (98%)	1.66	129 (18%) 1 1	23, 46, 62, 72	84 (12%)
2	D	603/690 (87%)	0.78	52 (8%) 10 12	23, 44, 63, 72	0
All	All	3101/3298 (94%)	1.04	383 (12%) 4 5	23, 35, 59, 90	100 (3%)

All (383) RSRZ outliers are listed below:

Mol	Chain	Res	Type	RSRZ
2	B	614	CYS	21.4
2	B	670	TYR	20.9
2	B	652	ALA	20.6
2	B	680	TYR	20.3
2	B	641	SER	19.6
2	B	682	VAL	17.5
2	B	640	GLU	17.0
2	B	634	TYR	15.9
2	B	624	ALA	15.6
2	B	669	TYR	15.2
2	B	681	VAL	14.6
2	B	629	ASN	14.6
2	B	666	ARG	13.9
2	B	627	ASP	13.8
2	B	675	GLY	13.1
2	B	664	VAL	12.8
2	B	676	LYS	12.6
2	B	642	VAL	12.3
2	B	631	CYS	12.1
2	B	628	GLU	12.0
2	B	689	LYS	11.2

Continued on next page...

Continued from previous page...

Mol	Chain	Res	Type	RSRZ
1	C	932	VAL	11.1
2	B	677	SER	10.7
2	B	610	PHE	10.7
2	B	633	ARG	10.6
2	B	646	LYS	10.6
2	B	672	ASP	10.4
2	B	688	CYS	10.3
2	B	615	VAL	10.1
2	B	673	SER	10.1
2	B	625	LEU	9.9
1	C	937	TYR	9.8
2	B	639	ILE	9.4
2	B	613	GLU	9.2
2	D	610	PHE	9.2
2	B	618	LYS	9.0
2	B	678	ILE	9.0
2	B	630	THR	9.0
1	A	941	PRO	8.6
1	C	802	HIS	8.5
1	C	887	VAL	8.5
1	C	922	PHE	8.4
2	B	656	THR	8.4
1	C	813	LEU	8.4
2	B	668	GLN	8.3
2	B	643	LYS	8.2
1	C	919	LEU	7.9
1	C	947	GLY	7.8
1	C	800	SER	7.8
1	C	801	ILE	7.8
2	B	653	VAL	7.8
2	B	690	GLY	7.6
1	A	621	SER	7.6
1	C	938	ALA	7.6
1	C	822	GLY	7.5
2	B	623	GLY	7.5
2	B	622	ARG	7.5
2	B	616	GLU	7.5
1	C	929	TRP	7.4
2	B	650	LYS	7.4
1	C	837	VAL	7.1
1	C	827	PHE	7.1
2	B	661	ASP	7.1

Continued on next page...

Continued from previous page...

Mol	Chain	Res	Type	RSRZ
1	C	952	TRP	6.9
2	B	466	TRP	6.9
2	B	617	CYS	6.8
2	B	10	VAL	6.7
2	B	655	CYS	6.7
1	C	914	LEU	6.7
2	B	665	VAL	6.7
2	B	685	PRO	6.7
2	B	667	PHE	6.6
2	B	679	LEU	6.6
1	A	578	ALA	6.6
1	C	909	LEU	6.5
2	B	611	LYS	6.5
2	B	645	LEU	6.4
1	C	797	LEU	6.3
2	B	647	ASP	6.3
2	B	638	GLU	6.3
1	C	910	TRP	6.2
1	C	911	LEU	6.1
2	B	674	SER	6.1
1	C	930	PHE	6.0
1	C	949	ALA	6.0
2	D	494	VAL	5.9
1	C	915	TYR	5.9
2	B	635	CYS	5.9
1	C	779	LYS	5.9
1	C	956	LEU	5.8
1	A	958	ALA	5.8
2	B	684	GLU	5.7
1	C	946	ARG	5.7
2	D	612	LYS	5.7
1	C	834	PRO	5.6
1	C	959	CYS	5.5
2	B	654	ASN	5.5
2	B	138	LEU	5.4
1	C	950	GLN	5.3
1	C	798	HIS	5.3
1	C	936	PRO	5.2
2	B	651	ASP	5.2
2	B	660	GLU	5.2
1	C	912	PRO	5.2
1	C	678	LYS	5.2

Continued on next page...

Continued from previous page...

Mol	Chain	Res	Type	RSRZ
2	B	609	THR	5.2
1	C	824	LEU	5.1
2	B	644	GLU	5.0
2	B	671	GLU	4.9
1	C	712	GLU	4.9
1	C	931	ASN	4.9
1	C	836	LYS	4.9
1	C	823	GLY	4.8
2	B	683	GLU	4.8
2	D	134	LEU	4.7
1	C	821[A]	GLN	4.7
1	C	958	ALA	4.6
2	B	626	HIS	4.6
1	C	908	PHE	4.6
1	C	920	ASP	4.6
2	B	197	THR	4.5
1	A	710	LEU	4.5
1	C	541	HIS	4.5
1	C	833	ASN	4.5
1	C	804	PRO	4.5
1	C	814	TYR	4.5
1	C	954	GLN	4.5
1	C	755	PHE	4.5
1	C	939	VAL	4.3
1	C	935	LEU	4.3
1	C	832	VAL	4.3
2	B	133	ASN	4.3
2	D	464	PRO	4.3
1	C	578	ALA	4.2
1	C	886	THR	4.2
2	B	649	GLY	4.2
1	A	839	TRP	4.2
2	B	375	LEU	4.1
1	C	820	PRO	4.1
2	B	33	LEU	4.1
2	B	134	LEU	4.1
2	D	573	LEU	4.0
2	D	104	VAL	4.0
1	C	778	PRO	4.0
2	D	9	GLY	4.0
1	C	945	PRO	4.0
1	A	713	ALA	4.0

Continued on next page...

Continued from previous page...

Mol	Chain	Res	Type	RSRZ
1	C	883	ALA	4.0
2	D	492	GLN	3.9
1	A	956	LEU	3.9
2	D	10	VAL	3.9
2	B	104	VAL	3.9
2	D	129	TRP	3.9
1	A	792	GLY	3.8
2	D	609	THR	3.8
1	A	940	PRO	3.8
1	C	780	VAL	3.8
2	B	658	LYS	3.8
1	C	829	GLN	3.8
1	C	794	VAL	3.8
1	A	655	GLN	3.8
2	B	61	ALA	3.8
1	C	784	TYR	3.7
1	C	878	VAL	3.7
1	C	928	ALA	3.7
1	A	939	VAL	3.7
1	C	713	ALA	3.7
1	C	941	PRO	3.6
1	C	885	CYS	3.6
1	C	799	LEU	3.6
1	C	927	HIS	3.6
2	B	145	LEU	3.6
2	B	621	ASP	3.6
2	D	4	ILE	3.6
1	C	877	LEU	3.6
1	A	776	TRP	3.6
1	C	828	PRO	3.6
1	C	816	LEU	3.6
1	C	892	LEU	3.6
2	D	374	CYS	3.5
1	C	884	PRO	3.5
2	B	467	LEU	3.5
1	C	895	MET	3.5
2	B	513	PHE	3.4
2	D	178	TYR	3.4
2	D	548	LEU	3.4
2	B	345	VAL	3.4
1	C	948	GLU	3.4
2	B	657	TYR	3.4

Continued on next page...

Continued from previous page...

Mol	Chain	Res	Type	RSRZ
1	C	943	SER	3.4
2	B	149	LEU	3.4
1	C	47	GLN	3.4
2	B	377	ASN	3.3
1	C	803	LEU	3.3
1	C	786	LEU	3.3
1	C	750	LEU	3.2
2	B	687	CYS	3.2
2	D	541	GLN	3.2
2	D	602	PRO	3.2
1	C	579	GLY	3.2
2	B	390	LYS	3.2
1	A	45	PRO	3.2
2	D	493	PRO	3.2
1	A	874	ASP	3.2
2	B	410	LYS	3.2
1	A	763	ALA	3.2
1	C	923	VAL	3.2
2	B	122	TYR	3.1
1	C	809	PRO	3.1
1	A	943	SER	3.1
1	C	795	ASN	3.1
1	C	815	ILE	3.1
2	B	620	PHE	3.1
1	A	762	ALA	3.1
2	D	557	TYR	3.1
2	B	502	LEU	3.1
2	B	632	ASN	3.1
2	B	659	ASN	3.1
1	C	944	LEU	3.1
2	D	145	LEU	3.1
1	A	924	LEU	3.0
2	D	574	LEU	3.0
1	C	679	GLU	3.0
1	A	321	LYS	3.0
1	C	880	CYS	3.0
1	C	917	ARG	3.0
1	C	916	GLN	3.0
2	D	131	ILE	3.0
2	B	62	ARG	3.0
2	D	577	GLY	3.0
1	A	837	VAL	2.9

Continued on next page...

Continued from previous page...

Mol	Chain	Res	Type	RSRZ
1	A	744	ALA	2.9
2	D	459	VAL	2.9
1	C	587[A]	HIS	2.9
1	C	668	GLY	2.9
2	B	378	GLU	2.9
2	B	607	ALA	2.9
1	C	918	PRO	2.9
1	C	888	VAL	2.9
1	A	579	GLY	2.9
1	A	212	LEU	2.9
2	D	33	LEU	2.9
1	C	826	CYS	2.9
1	A	214	TRP	2.9
1	C	924	LEU	2.8
1	A	929[A]	TRP	2.8
1	A	628	ASP	2.8
1	C	817	ASP	2.8
2	D	357	LEU	2.8
1	C	891	ASP	2.8
1	C	785	GLU	2.8
2	D	466	TRP	2.8
1	C	819	GLN	2.8
1	A	836	LYS	2.8
2	D	182	THR	2.7
2	D	138	LEU	2.7
1	C	559[A]	ARG	2.7
1	A	668	GLY	2.7
1	C	901	ALA	2.7
2	D	133	ASN	2.7
1	C	217	SER	2.7
1	C	48	GLU	2.7
1	C	889	GLN	2.7
1	C	744	ALA	2.7
1	A	944	LEU	2.7
1	A	678	LYS	2.6
1	A	927	HIS	2.6
1	A	959	CYS	2.6
2	B	129	TRP	2.6
2	B	212	VAL	2.6
2	D	587	VAL	2.6
1	A	682	THR	2.6
1	A	759	LEU	2.6

Continued on next page...

Continued from previous page...

Mol	Chain	Res	Type	RSRZ
2	B	637	ASP	2.6
2	D	391	ILE	2.6
2	B	608	CYS	2.6
2	D	239	ARG	2.6
1	C	655	GLN	2.6
2	B	340	VAL	2.6
1	A	919	LEU	2.6
1	A	893	GLN	2.6
2	B	612	LYS	2.6
1	C	756	PRO	2.6
2	B	142	MET	2.6
1	C	710	LEU	2.6
2	D	151	ILE	2.6
2	D	390	LYS	2.6
1	C	896	ALA	2.5
1	A	47	GLN	2.5
1	A	580	MET	2.5
2	D	1	GLY	2.5
2	B	397	PHE	2.5
2	D	475	GLU	2.5
1	C	502	LEU	2.5
2	D	34	GLY	2.5
2	D	181	LYS	2.5
1	C	746	ALA	2.5
2	D	411	GLU	2.5
1	C	905	VAL	2.5
1	C	680	ASN	2.5
2	B	1	GLY	2.5
2	B	578	ARG	2.5
1	A	493	ALA	2.5
1	C	933	SER	2.5
2	B	515	LYS	2.5
1	C	582	PRO	2.5
2	B	69	LEU	2.5
1	A	695	LYS	2.5
2	D	203	PHE	2.5
1	A	797	LEU	2.4
1	C	116	LEU	2.4
1	A	835	LEU	2.4
2	B	131	ILE	2.4
2	D	513	PHE	2.4
2	B	465	GLY	2.4

Continued on next page...

Continued from previous page...

Mol	Chain	Res	Type	RSRZ
2	B	92	LEU	2.4
1	C	792	GLY	2.4
2	B	178	TYR	2.4
2	B	433	CYS	2.4
1	A	217	SER	2.4
1	A	671[A]	ARG	2.4
2	D	143	ARG	2.4
1	C	881	ASP	2.4
2	B	9	GLY	2.3
1	C	942	LEU	2.3
1	A	952	TRP	2.3
1	A	707	VAL	2.3
1	C	903	VAL	2.3
1	C	321	LYS	2.3
2	D	373	THR	2.3
2	B	83	VAL	2.3
2	B	304	ILE	2.3
1	A	153	ARG	2.3
1	C	783	THR	2.3
1	C	340	LEU	2.3
1	C	600	LEU	2.3
2	D	483	GLN	2.3
2	B	110	TYR	2.3
2	D	567	CYS	2.3
1	A	942	LEU	2.3
1	C	517	GLN	2.3
1	C	542	SER	2.3
1	A	587[A]	HIS	2.3
1	A	213	LEU	2.3
1	C	925	GLN	2.2
1	A	541	HIS	2.2
2	D	69	LEU	2.2
1	C	50	THR	2.2
1	C	682	THR	2.2
1	C	322	LEU	2.2
2	B	379	VAL	2.2
1	C	516	ARG	2.2
2	B	447	ARG	2.2
2	B	606	ASP	2.2
1	C	906	LEU	2.2
2	D	2	PRO	2.2
2	D	196	LEU	2.2

Continued on next page...

Continued from previous page...

Mol	Chain	Res	Type	RSRZ
2	D	529	VAL	2.2
1	A	149	ASN	2.2
2	B	237	GLY	2.2
1	A	669[A]	PHE	2.2
2	B	563	ARG	2.2
2	D	491	GLY	2.2
1	C	731	PRO	2.2
1	A	824	LEU	2.2
1	C	531	THR	2.1
2	B	107	VAL	2.1
1	A	43	LEU	2.1
1	C	810	SER	2.1
1	A	827	PHE	2.1
1	C	604	GLU	2.1
1	A	838	ASP	2.1
1	C	670	GLU	2.1
1	C	671	ARG	2.1
1	C	745	GLU	2.1
2	B	188	PHE	2.1
1	A	472	SER	2.0
1	C	874	ASP	2.0
2	B	310	VAL	2.0
2	B	500	GLU	2.0
2	B	374	CYS	2.0
1	A	813	LEU	2.0
2	B	132	GLN	2.0

6.2 Non-standard residues in protein, DNA, RNA chains [\(i\)](#)

There are no non-standard protein/DNA/RNA residues in this entry.

6.3 Carbohydrates [\(i\)](#)

In the following table, the Atoms column lists the number of modelled atoms in the group and the number defined in the chemical component dictionary. The B-factors column lists the minimum, median, 95th percentile and maximum values of B factors of atoms in the group. The column labelled 'Q<0.9' lists the number of atoms with occupancy less than 0.9.

Mol	Type	Chain	Res	Atoms	RSCC	RSR	B-factors(Å ²)	Q<0.9
6	MAN	I	5	11/12	0.42	0.32	94,95,96,96	0
6	MAN	I	3	11/12	0.51	0.21	87,88,90,92	0

Continued on next page...

Continued from previous page...

Mol	Type	Chain	Res	Atoms	RSCC	RSR	B-factors(\AA^2)	Q<0.9
6	MAN	I	4	11/12	0.57	0.39	94,94,95,95	0
3	NAG	M	2	14/15	0.66	0.37	90,91,92,92	0
3	NAG	M	1	14/15	0.69	0.32	83,86,87,89	0
4	MAN	F	3	11/12	0.70	0.23	89,90,91,92	0
3	NAG	H	2	14/15	0.71	0.42	88,89,90,90	0
4	MAN	F	4	11/12	0.73	0.25	92,93,94,94	0
3	NAG	J	2	14/15	0.76	0.46	66,69,69,69	0
3	NAG	E	2	14/15	0.76	0.42	77,78,78,79	0
6	NAG	I	2	14/15	0.77	0.27	79,80,83,85	0
3	NAG	L	2	14/15	0.78	0.30	61,62,63,64	0
3	NAG	N	2	14/15	0.78	0.32	75,76,78,78	0
3	NAG	N	1	14/15	0.81	0.28	69,72,74,75	0
4	NAG	F	2	14/15	0.81	0.37	77,79,83,86	0
3	NAG	E	1	14/15	0.82	0.33	71,73,75,76	0
3	NAG	H	1	14/15	0.82	0.29	81,82,84,86	0
5	NAG	G	2	14/15	0.84	0.25	66,69,70,72	0
5	MAN	G	3	11/12	0.84	0.31	73,74,75,75	0
4	NAG	F	1	14/15	0.84	0.32	61,65,69,74	0
6	NAG	I	1	14/15	0.88	0.16	68,69,72,75	0
3	NAG	J	1	14/15	0.89	0.21	51,56,58,62	0
3	NAG	K	2	14/15	0.89	0.26	66,69,69,69	0
3	NAG	K	1	14/15	0.90	0.14	55,57,60,63	0
5	NAG	G	1	14/15	0.91	0.18	51,54,57,62	0
3	NAG	L	1	14/15	0.92	0.17	55,56,59,60	0

The following is a graphical depiction of the model fit to experimental electron density for oligosaccharide. Each fit is shown from different orientation to approximate a three-dimensional view.

Electron density around Chain E:

$2mF_o-DF_c$ (at 0.7 rmsd) in gray
 mF_o-DF_c (at 3 rmsd) in purple (negative)
and green (positive)

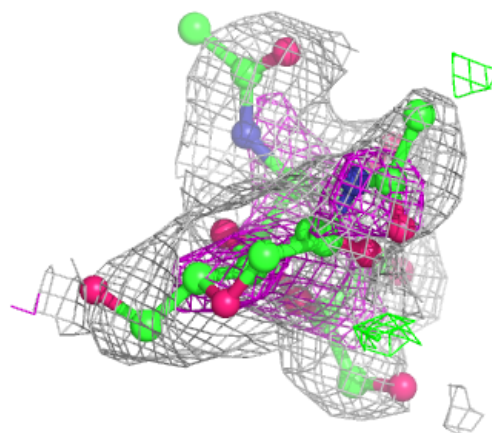
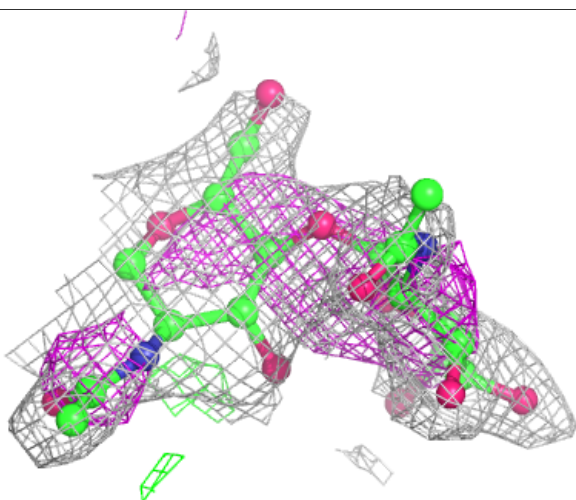
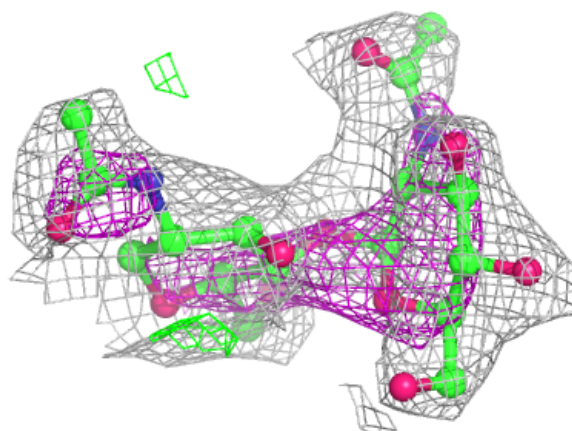

Electron density around Chain H:

$2mF_o-DF_c$ (at 0.7 rmsd) in gray
 mF_o-DF_c (at 3 rmsd) in purple (negative)
and green (positive)

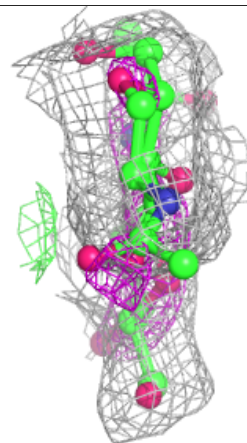
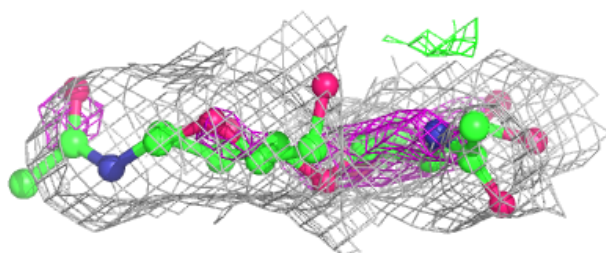
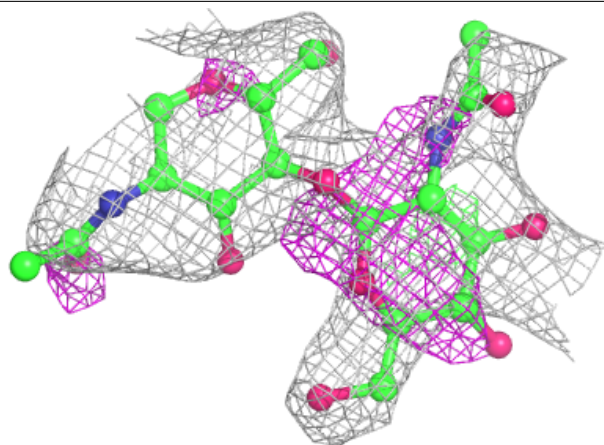

Electron density around Chain J:

$2mF_o-DF_c$ (at 0.7 rmsd) in gray
 mF_o-DF_c (at 3 rmsd) in purple (negative)
and green (positive)

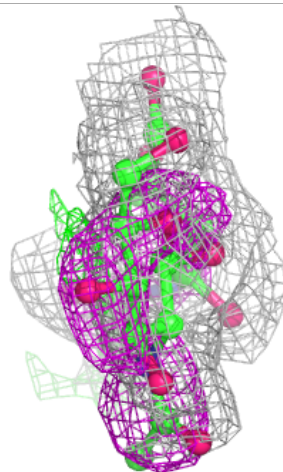
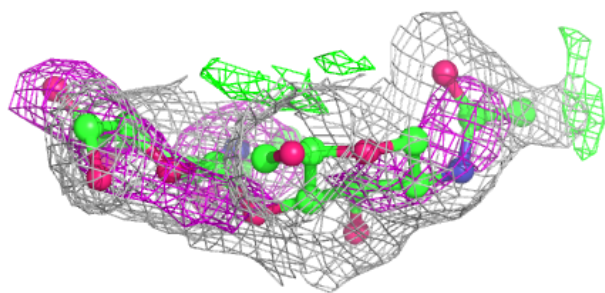
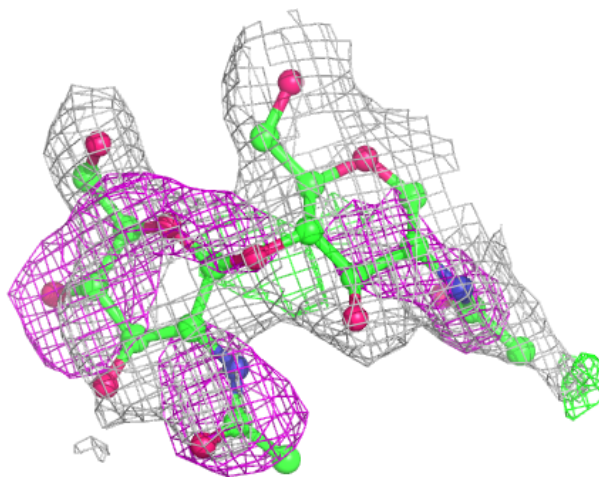

Electron density around Chain K:

$2mF_o-DF_c$ (at 0.7 rmsd) in gray
 mF_o-DF_c (at 3 rmsd) in purple (negative)
and green (positive)

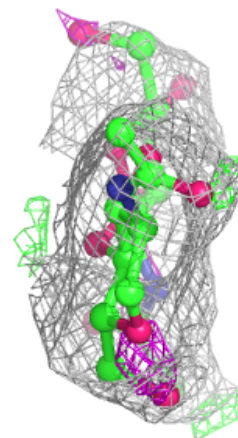
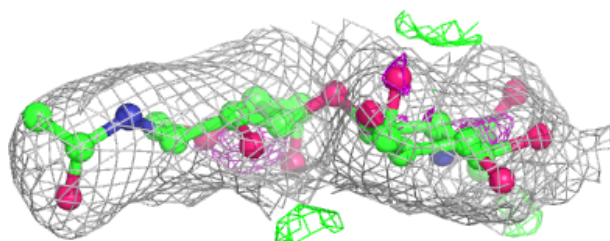
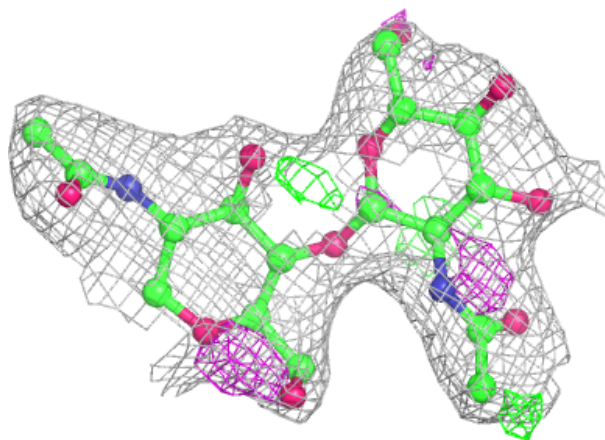

Electron density around Chain L:

$2mF_o-DF_c$ (at 0.7 rmsd) in gray
 mF_o-DF_c (at 3 rmsd) in purple (negative)
and green (positive)

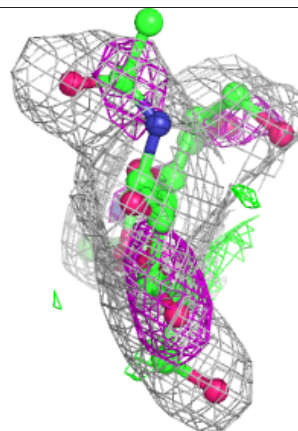
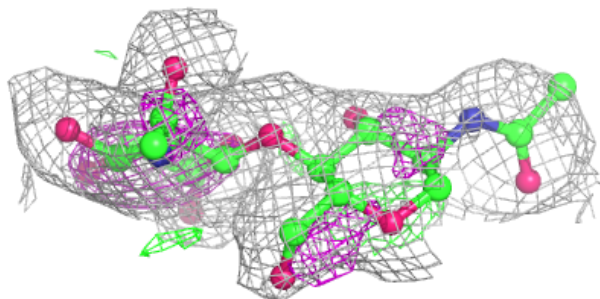
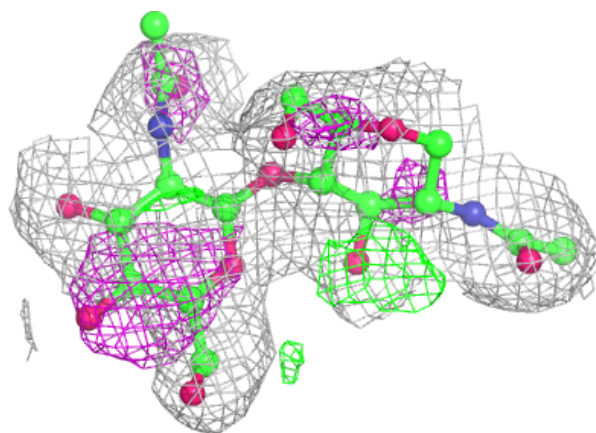
**Electron density around Chain M:**

$2mF_o-DF_c$ (at 0.7 rmsd) in gray
 mF_o-DF_c (at 3 rmsd) in purple (negative)
and green (positive)

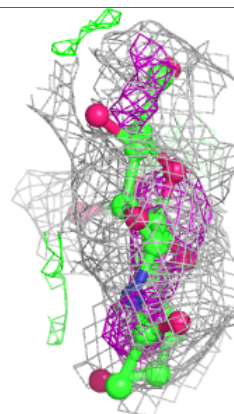
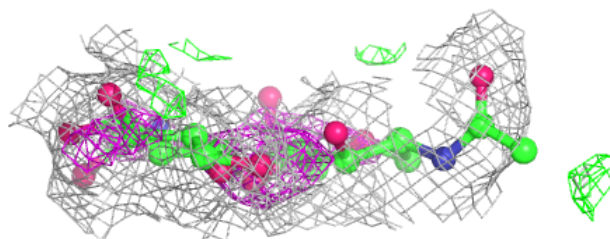
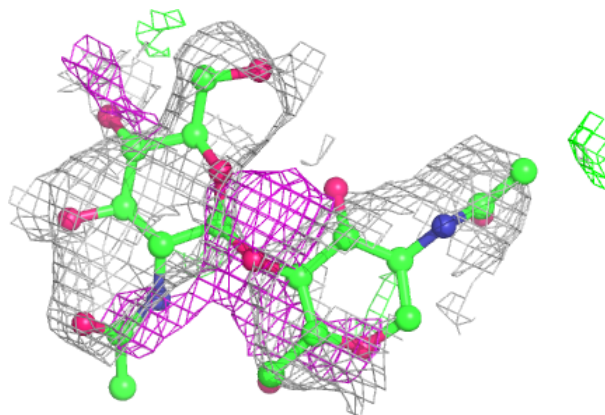

Electron density around Chain N:

$2mF_o-DF_c$ (at 0.7 rmsd) in gray
 mF_o-DF_c (at 3 rmsd) in purple (negative)
and green (positive)

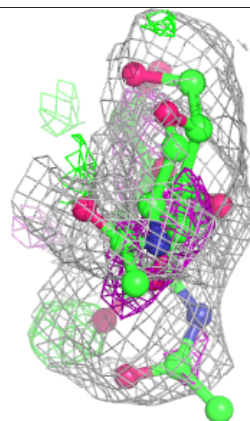
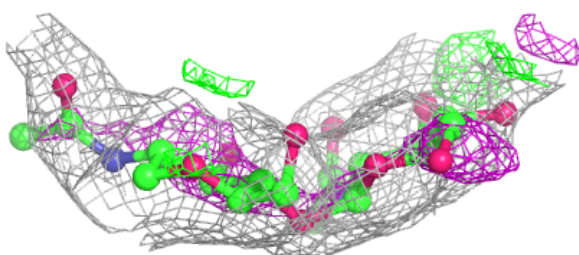
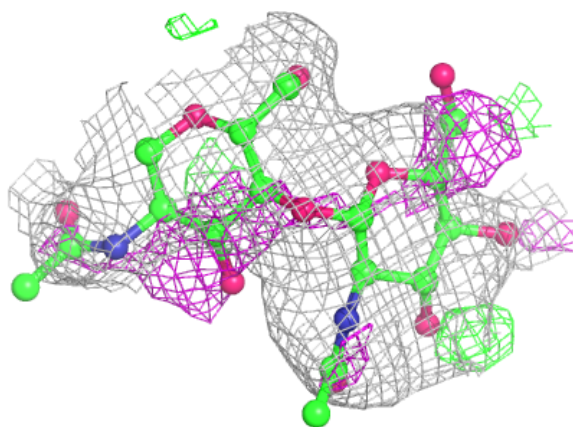
**Electron density around Chain F:**

$2mF_o-DF_c$ (at 0.7 rmsd) in gray
 mF_o-DF_c (at 3 rmsd) in purple (negative)
and green (positive)

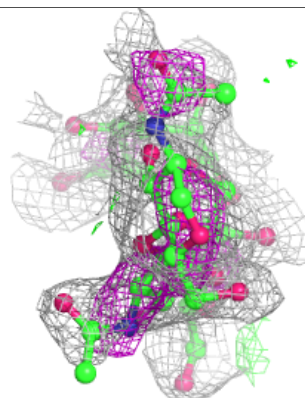
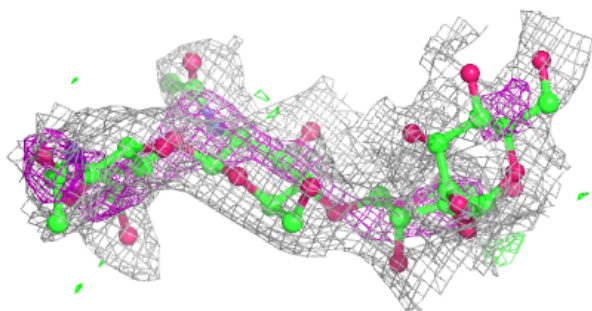
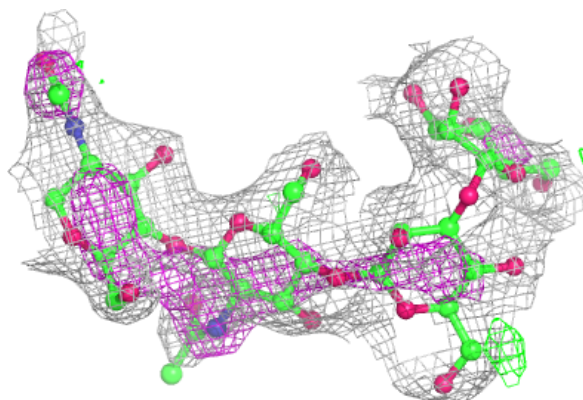

Electron density around Chain G:

$2mF_o-DF_c$ (at 0.7 rmsd) in gray
 mF_o-DF_c (at 3 rmsd) in purple (negative)
and green (positive)

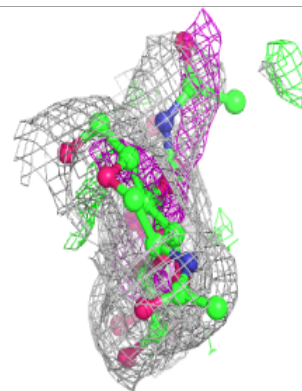
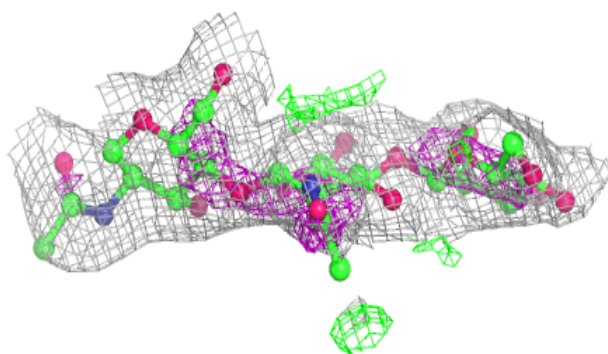
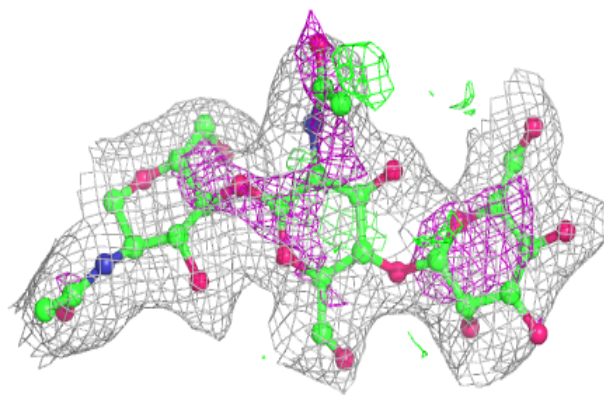
**Electron density around Chain I:**

$2mF_o-DF_c$ (at 0.7 rmsd) in gray
 mF_o-DF_c (at 3 rmsd) in purple (negative)
and green (positive)

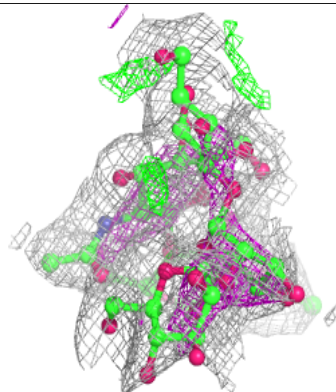
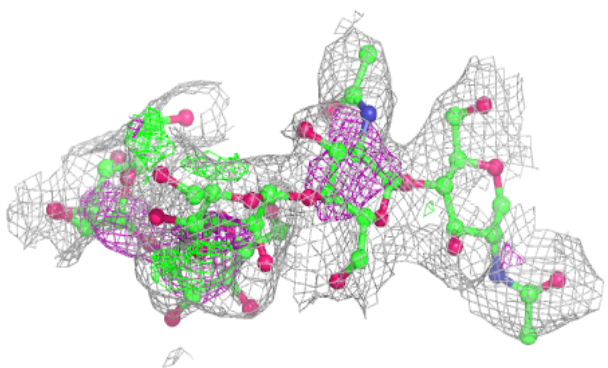
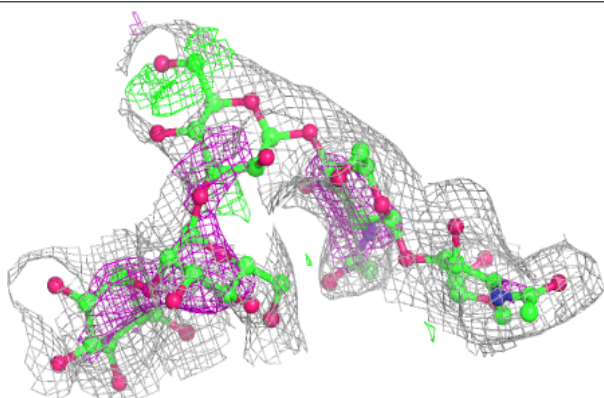

6.4 Ligands [i](#)

In the following table, the Atoms column lists the number of modelled atoms in the group and the number defined in the chemical component dictionary. The B-factors column lists the minimum, median, 95th percentile and maximum values of B factors of atoms in the group. The column labelled 'Q< 0.9' lists the number of atoms with occupancy less than 0.9.

Mol	Type	Chain	Res	Atoms	RSCC	RSR	B-factors(Å ²)	Q<0.9
10	MG	D	2001	1/1	0.74	0.10	23,23,23,23	0
8	NAG	D	3099	14/15	0.78	0.35	71,73,74,74	0
8	NAG	C	3015	14/15	0.81	0.27	51,55,55,56	0
10	MG	B	2001	1/1	0.82	0.10	23,23,23,23	0
8	NAG	C	3570	14/15	0.83	0.29	45,48,49,50	0
8	NAG	A	3570	14/15	0.86	0.24	35,38,39,39	14
7	CA	B	2002	1/1	0.88	0.10	34,34,34,34	0
7	CA	C	2008	1/1	0.90	0.15	14,14,14,14	0
8	NAG	A	3015	14/15	0.90	0.29	52,55,57,58	0
9	IMD	C	5001	5/5	0.91	0.18	52,52,52,52	0
7	CA	A	2007	1/1	0.91	0.21	20,20,20,20	0
7	CA	C	2005	1/1	0.91	0.22	41,41,41,41	0
7	CA	C	2006	1/1	0.92	0.16	29,29,29,29	0
9	IMD	C	5003	5/5	0.92	0.38	28,29,29,29	0
7	CA	A	2004	1/1	0.93	0.10	25,25,25,25	0
7	CA	A	2006	1/1	0.93	0.17	29,29,29,29	0
7	CA	C	2007	1/1	0.95	0.26	23,23,23,23	0
7	CA	A	2008	1/1	0.95	0.12	23,23,23,23	0
7	CA	D	2002	1/1	0.95	0.20	42,42,42,42	0
7	CA	B	2003	1/1	0.95	0.15	37,37,37,37	0
9	IMD	C	5004	5/5	0.96	0.35	47,48,48,48	0
9	IMD	C	960	5/5	0.96	0.16	33,33,34,34	0
9	IMD	A	5001	5/5	0.96	0.21	37,37,37,38	0
9	IMD	C	5002	5/5	0.97	0.16	21,21,21,22	0
7	CA	A	2005	1/1	0.98	0.21	17,17,17,17	0
7	CA	D	2003	1/1	0.98	0.17	26,26,26,26	0
7	CA	C	2004	1/1	0.98	0.21	29,29,29,29	0

6.5 Other polymers [i](#)

There are no such residues in this entry.