



wwPDB X-ray Structure Validation Summary Report ⓘ

Aug 22, 2023 – 04:10 AM EDT

PDB ID : 2Q4E
Title : Ensemble refinement of the protein crystal structure of gene product from Arabidopsis thaliana At4g09670
Authors : Levin, E.J.; Kondrashov, D.A.; Wesenberg, G.E.; Phillips Jr., G.N.; Center for Eukaryotic Structural Genomics (CESG)
Deposited on : 2007-05-31
Resolution : 2.49 Å(reported)

This is a wwPDB X-ray Structure Validation Summary Report for a publicly released PDB entry.

We welcome your comments at validation@mail.wwpdb.org

A user guide is available at

<https://www.wwpdb.org/validation/2017/XrayValidationReportHelp>

with specific help available everywhere you see the ⓘ symbol.

The types of validation reports are described at

<http://www.wwpdb.org/validation/2017/FAQs#types>.

The following versions of software and data (see [references ⓘ](#)) were used in the production of this report:

MolProbity : 4.02b-467
Mogul : 1.8.5 (274361), CSD as541be (2020)
Xtriage (Phenix) : 1.13
EDS : 2.35
Percentile statistics : 20191225.v01 (using entries in the PDB archive December 25th 2019)
Refmac : 5.8.0158
CCP4 : 7.0.044 (Gargrove)
Ideal geometry (proteins) : Engh & Huber (2001)
Ideal geometry (DNA, RNA) : Parkinson et al. (1996)
Validation Pipeline (wwPDB-VP) : 2.35

1 Overall quality at a glance

The following experimental techniques were used to determine the structure:

X-RAY DIFFRACTION

The reported resolution of this entry is 2.49 Å.

Percentile scores (ranging between 0-100) for global validation metrics of the entry are shown in the following graphic. The table shows the number of entries on which the scores are based.

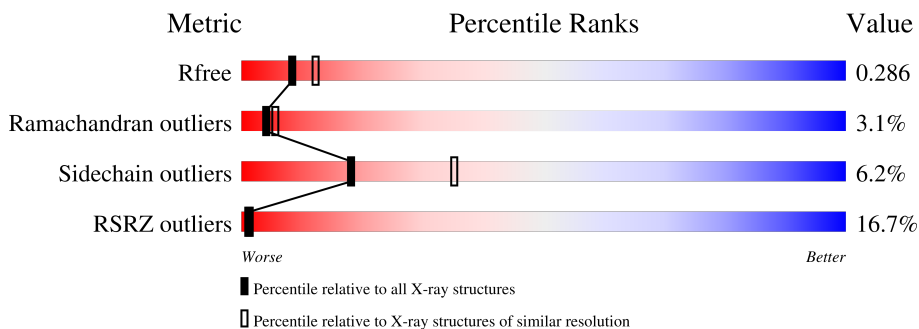

Metric	Whole archive (#Entries)	Similar resolution (#Entries, resolution range(Å))
R_{free}	130704	4661 (2.50-2.50)
Ramachandran outliers	138981	5231 (2.50-2.50)
Sidechain outliers	138945	5233 (2.50-2.50)
RSRZ outliers	127900	4559 (2.50-2.50)

The table below summarises the geometric issues observed across the polymeric chains and their fit to the electron density. The red, orange, yellow and green segments of the lower bar indicate the fraction of residues that contain outliers for ≥ 3 , 2, 1 and 0 types of geometric quality criteria respectively. A grey segment represents the fraction of residues that are not modelled. The numeric value for each fraction is indicated below the corresponding segment, with a dot representing fractions $\leq 5\%$. The upper red bar (where present) indicates the fraction of residues that have poor fit to the electron density. The numeric value is given above the bar.

Mol	Chain	Length	Quality of chain
1	1-A	362	
1	1-B	362	
1	10-A	362	
1	10-B	362	
1	11-A	362	
1	11-B	362	
1	12-A	362	

Continued on next page...

Continued from previous page...

Mol	Chain	Length	Quality of chain
1	12-B	362	14% 90% 7% .
1	13-A	362	21% 85% 9% . 5%
1	13-B	362	14% 90% 7% .
1	14-A	362	21% 84% 10% 5%
1	14-B	362	14% 88% 9% .
1	15-A	362	21% 83% 12% . 5%
1	15-B	362	14% 85% 12% .
1	16-A	362	21% 83% 10% . 5%
1	16-B	362	14% 84% 12% .
1	2-A	362	21% 89% 6% 5%
1	2-B	362	14% 92% 5% .
1	3-A	362	21% 85% 9% . 5%
1	3-B	362	14% 90% 6% .
1	4-A	362	21% 86% 9% 5%
1	4-B	362	14% 93% . .
1	5-A	362	21% 88% 7% 5%
1	5-B	362	14% 91% 6% .
1	6-A	362	21% 89% 5% . 5%
1	6-B	362	14% 91% 6% .
1	7-A	362	21% 86% 9% 5%
1	7-B	362	14% 90% 6% . .
1	8-A	362	21% 88% 6% 5%
1	8-B	362	14% 90% 6% .
1	9-A	362	21% 88% 6% 5%
1	9-B	362	14% 91% 5% .

2 Entry composition [i](#)

There are 2 unique types of molecules in this entry. The entry contains 87408 atoms, of which 0 are hydrogens and 0 are deuteriums.

In the tables below, the ZeroOcc column contains the number of atoms modelled with zero occupancy, the AltConf column contains the number of residues with at least one atom in alternate conformation and the Trace column contains the number of residues modelled with at most 2 atoms.

- Molecule 1 is a protein called Probable oxidoreductase At4g09670.

Mol	Chain	Residues	Atoms						ZeroOcc	AltConf	Trace
			Total	C	N	O	S	Se			
1	1-A	343	2648	1687	445	504	6	6	0	0	0
1	2-A	343	2648	1687	445	504	6	6	0	0	0
1	3-A	343	2648	1687	445	504	6	6	0	0	0
1	4-A	343	2648	1687	445	504	6	6	0	0	0
1	5-A	343	2648	1687	445	504	6	6	0	0	0
1	6-A	343	2648	1687	445	504	6	6	0	0	0
1	7-A	343	2648	1687	445	504	6	6	0	0	0
1	8-A	343	2648	1687	445	504	6	6	0	0	0
1	9-A	343	2648	1687	445	504	6	6	0	0	0
1	10-A	343	2648	1687	445	504	6	6	0	0	0
1	11-A	343	2648	1687	445	504	6	6	0	0	0
1	12-A	343	2648	1687	445	504	6	6	0	0	0
1	13-A	343	2648	1687	445	504	6	6	0	0	0
1	14-A	343	2648	1687	445	504	6	6	0	0	0
1	15-A	343	2648	1687	445	504	6	6	0	0	0
1	16-A	343	2648	1687	445	504	6	6	0	0	0

Continued on next page...

Continued from previous page...

Mol	Chain	Residues	Atoms						ZeroOcc	AltConf	Trace
1	1-B	350	Total	C	N	O	S	Se	0	0	0
			2692	1712	453	515	6	6			
1	2-B	350	Total	C	N	O	S	Se	0	0	0
			2692	1712	453	515	6	6			
1	3-B	350	Total	C	N	O	S	Se	0	0	0
			2692	1712	453	515	6	6			
1	4-B	350	Total	C	N	O	S	Se	0	0	0
			2692	1712	453	515	6	6			
1	5-B	350	Total	C	N	O	S	Se	0	0	0
			2692	1712	453	515	6	6			
1	6-B	350	Total	C	N	O	S	Se	0	0	0
			2692	1712	453	515	6	6			
1	7-B	350	Total	C	N	O	S	Se	0	0	0
			2692	1712	453	515	6	6			
1	8-B	350	Total	C	N	O	S	Se	0	0	0
			2692	1712	453	515	6	6			
1	9-B	350	Total	C	N	O	S	Se	0	0	0
			2692	1712	453	515	6	6			
1	10-B	350	Total	C	N	O	S	Se	0	0	0
			2692	1712	453	515	6	6			
1	11-B	350	Total	C	N	O	S	Se	0	0	0
			2692	1712	453	515	6	6			
1	12-B	350	Total	C	N	O	S	Se	0	0	0
			2692	1712	453	515	6	6			
1	13-B	350	Total	C	N	O	S	Se	0	0	0
			2692	1712	453	515	6	6			
1	14-B	350	Total	C	N	O	S	Se	0	0	0
			2692	1712	453	515	6	6			
1	15-B	350	Total	C	N	O	S	Se	0	0	0
			2692	1712	453	515	6	6			
1	16-B	350	Total	C	N	O	S	Se	0	0	0
			2692	1712	453	515	6	6			

There are 14 discrepancies between the modelled and reference sequences:

Chain	Residue	Modelled	Actual	Comment	Reference
A	1	SER	-	expression tag	UNP Q9SZ83
A	12	MSE	MET	modified residue	UNP Q9SZ83
A	106	MSE	MET	modified residue	UNP Q9SZ83
A	126	MSE	MET	modified residue	UNP Q9SZ83
A	130	MSE	MET	modified residue	UNP Q9SZ83
A	249	MSE	MET	modified residue	UNP Q9SZ83
A	310	MSE	MET	modified residue	UNP Q9SZ83

Continued on next page...

Continued from previous page...

Chain	Residue	Modelled	Actual	Comment	Reference
B	1	SER	-	expression tag	UNP Q9SZ83
B	12	MSE	MET	modified residue	UNP Q9SZ83
B	106	MSE	MET	modified residue	UNP Q9SZ83
B	126	MSE	MET	modified residue	UNP Q9SZ83
B	130	MSE	MET	modified residue	UNP Q9SZ83
B	249	MSE	MET	modified residue	UNP Q9SZ83
B	310	MSE	MET	modified residue	UNP Q9SZ83

- Molecule 2 is water.

Mol	Chain	Residues	Atoms	ZeroOcc	AltConf
2	1-A	60	Total O 60 60	0	0
2	2-A	58	Total O 58 58	0	0
2	3-A	62	Total O 62 62	0	0
2	4-A	60	Total O 60 60	0	0
2	5-A	59	Total O 59 59	0	0
2	6-A	60	Total O 60 60	0	0
2	7-A	61	Total O 61 61	0	0
2	8-A	56	Total O 56 56	0	0
2	9-A	60	Total O 60 60	0	0
2	10-A	59	Total O 59 59	0	0
2	11-A	60	Total O 60 60	0	0
2	12-A	61	Total O 61 61	0	0
2	13-A	62	Total O 62 62	0	0
2	14-A	59	Total O 59 59	0	0
2	15-A	59	Total O 59 59	0	0
2	16-A	60	Total O 60 60	0	0

Continued on next page...

Continued from previous page...

Mol	Chain	Residues	Atoms	ZeroOcc	AltConf
2	1-B	63	Total O 63 63	0	0
2	2-B	65	Total O 65 65	0	0
2	3-B	61	Total O 61 61	0	0
2	4-B	63	Total O 63 63	0	0
2	5-B	64	Total O 64 64	0	0
2	6-B	63	Total O 63 63	0	0
2	7-B	62	Total O 62 62	0	0
2	8-B	67	Total O 67 67	0	0
2	9-B	63	Total O 63 63	0	0
2	10-B	64	Total O 64 64	0	0
2	11-B	63	Total O 63 63	0	0
2	12-B	62	Total O 62 62	0	0
2	13-B	61	Total O 61 61	0	0
2	14-B	64	Total O 64 64	0	0
2	15-B	64	Total O 64 64	0	0
2	16-B	63	Total O 63 63	0	0

3 Residue-property plots [i](#)

These plots are drawn for all protein, RNA, DNA and oligosaccharide chains in the entry. The first graphic for a chain summarises the proportions of the various outlier classes displayed in the second graphic. The second graphic shows the sequence view annotated by issues in geometry and electron density. Residues are color-coded according to the number of geometric quality criteria for which they contain at least one outlier: green = 0, yellow = 1, orange = 2 and red = 3 or more. A red dot above a residue indicates a poor fit to the electron density ($RSRZ > 2$). Stretches of 2 or more consecutive residues without any outlier are shown as a green connector. Residues present in the sample, but not in the model, are shown in grey.

- Molecule 1: Probable oxidoreductase At4g09670

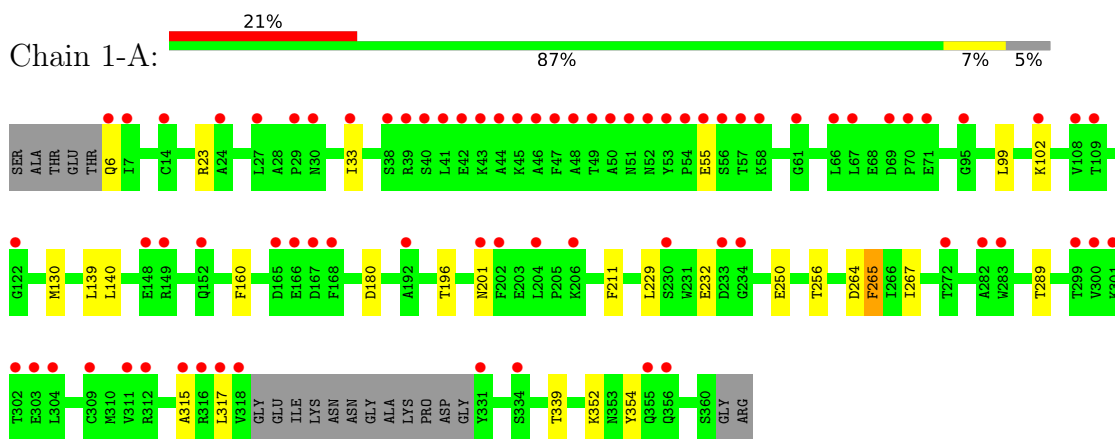

- Molecule 1: Probable oxidoreductase At4g09670

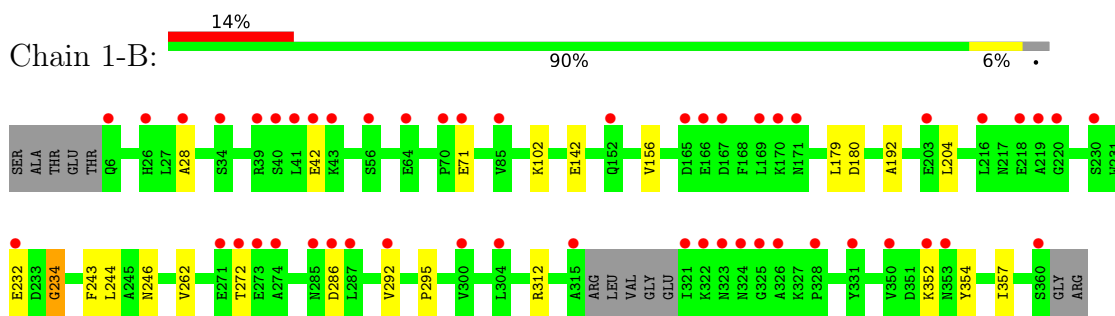

- Molecule 1: Probable oxidoreductase At4g09670

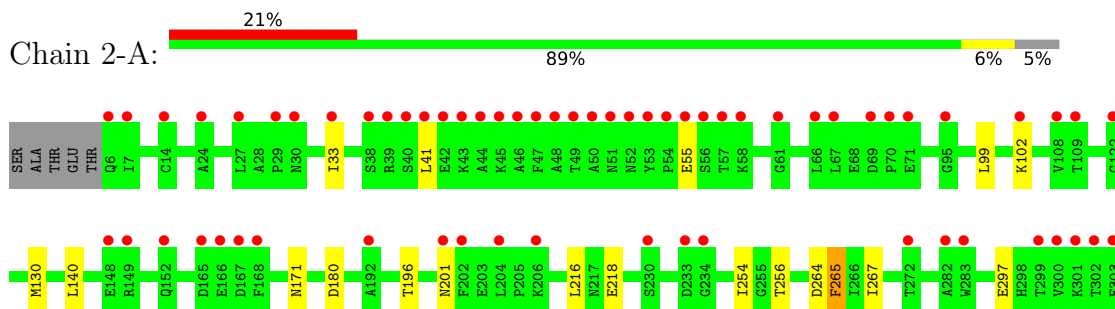

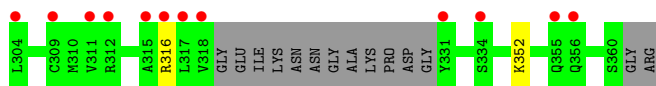

- Molecule 1: Probable oxidoreductase At4g09670

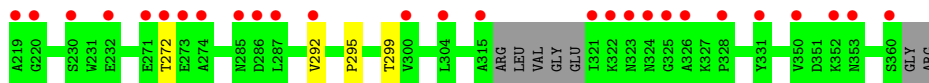
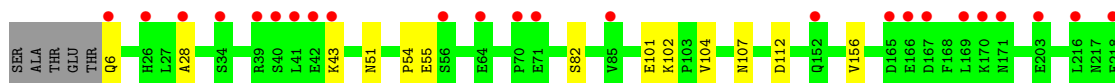

- Molecule 1: Probable oxidoreductase At4g09670

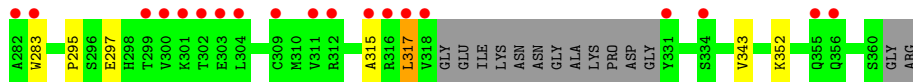
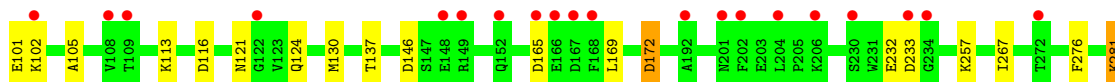
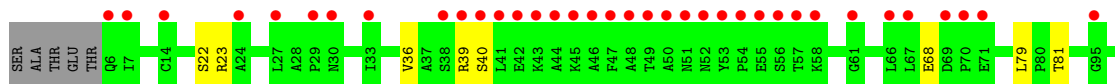
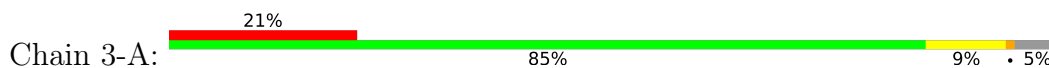

- Molecule 1: Probable oxidoreductase At4g09670

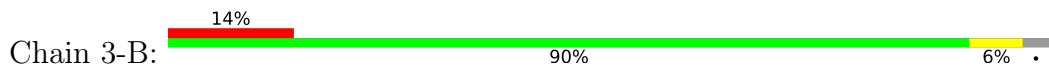

- Molecule 1: Probable oxidoreductase At4g09670

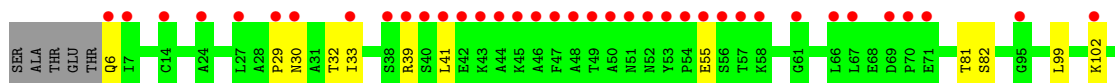
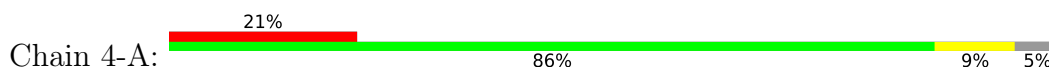

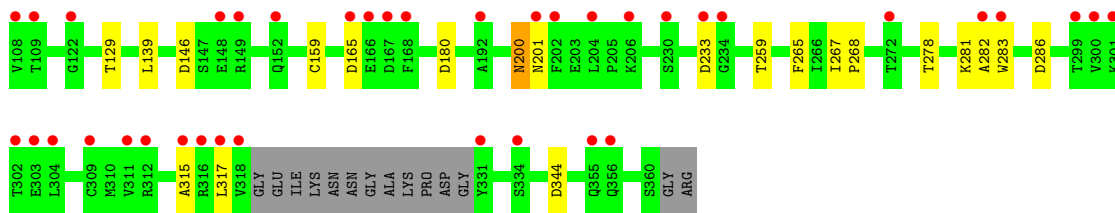

● Molecule 1: Probable oxidoreductase At4g09670

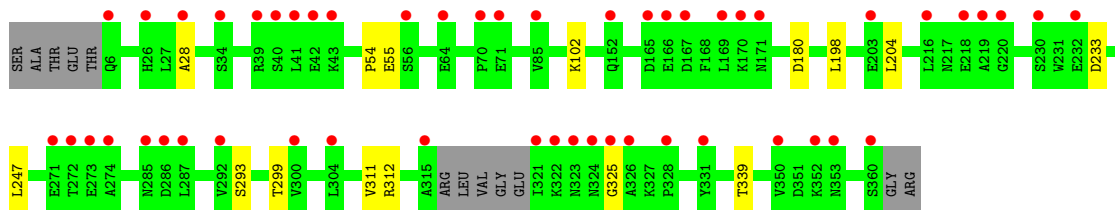

● Molecule 1: Probable oxidoreductase At4g09670

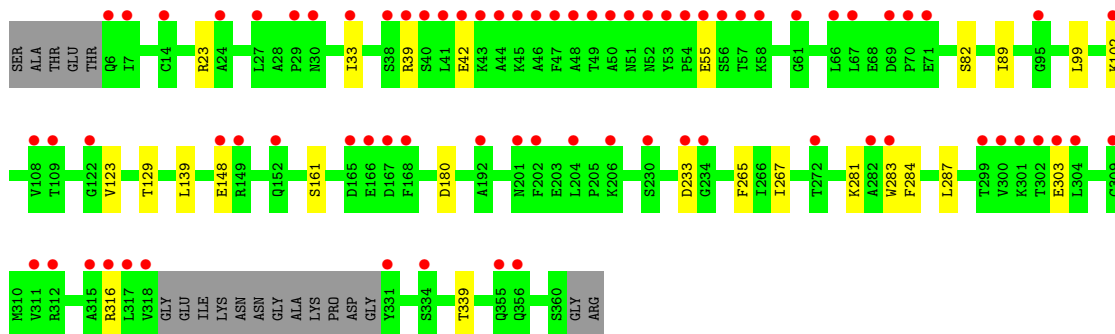
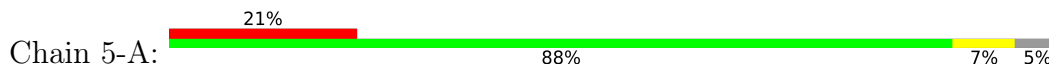

● Molecule 1: Probable oxidoreductase At4g09670

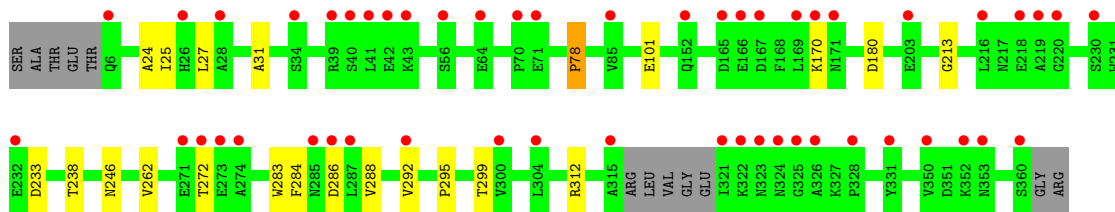
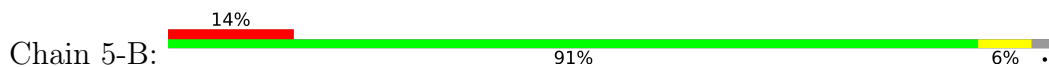

● Molecule 1: Probable oxidoreductase At4g09670

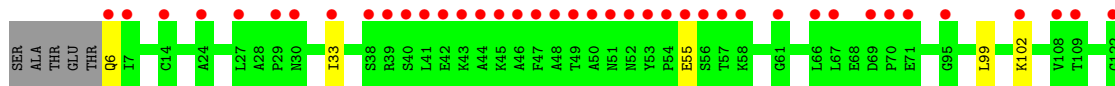
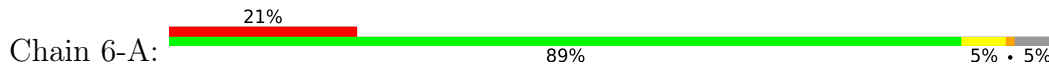

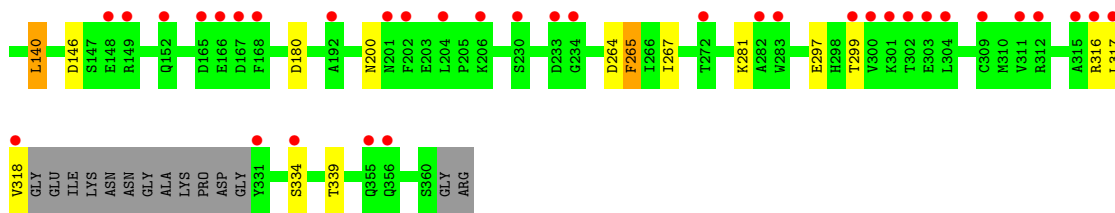

- Molecule 1: Probable oxidoreductase At4g09670

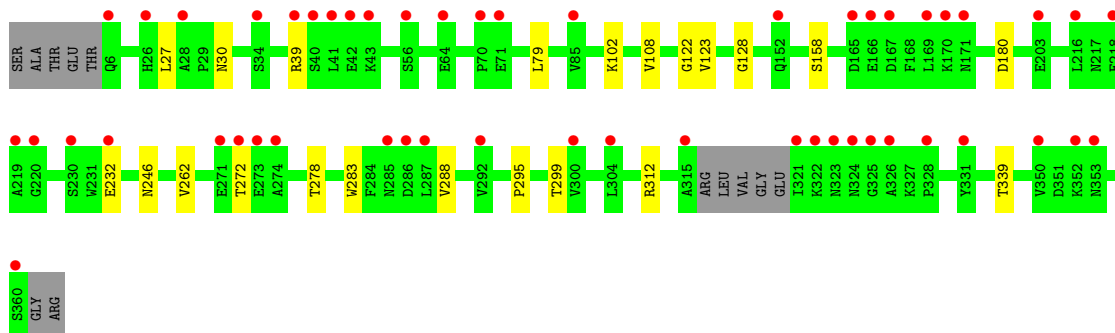

- Molecule 1: Probable oxidoreductase At4g09670

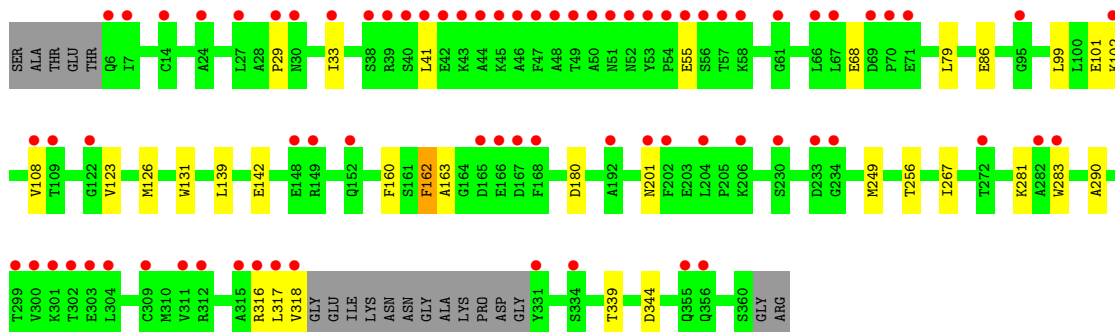
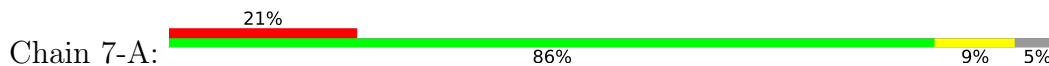

- Molecule 1: Probable oxidoreductase At4g09670

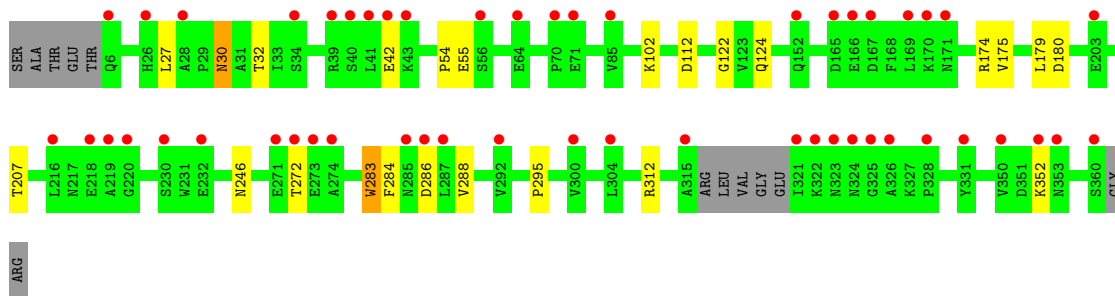
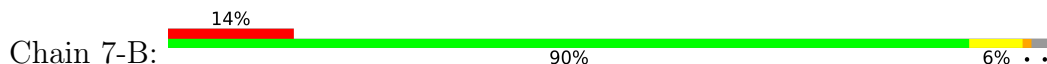

- Molecule 1: Probable oxidoreductase At4g09670

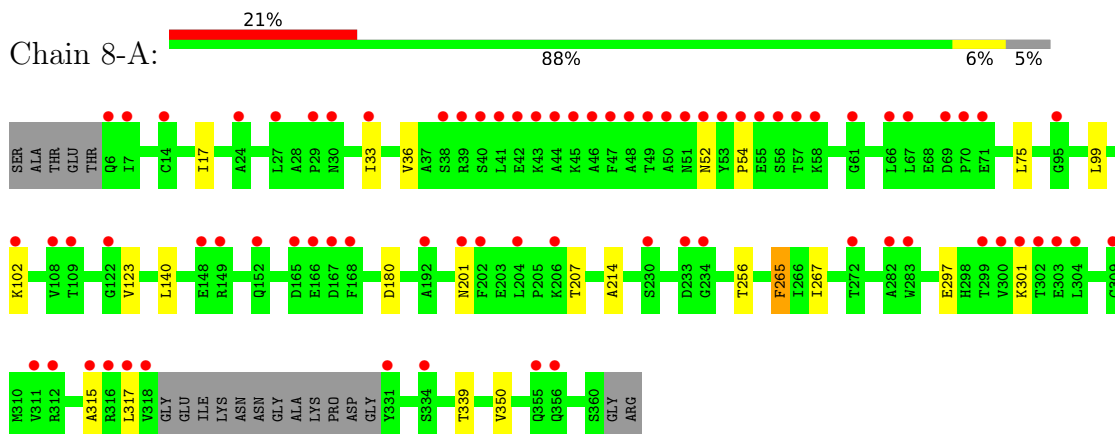

• Molecule 1: Probable oxidoreductase At4g09670

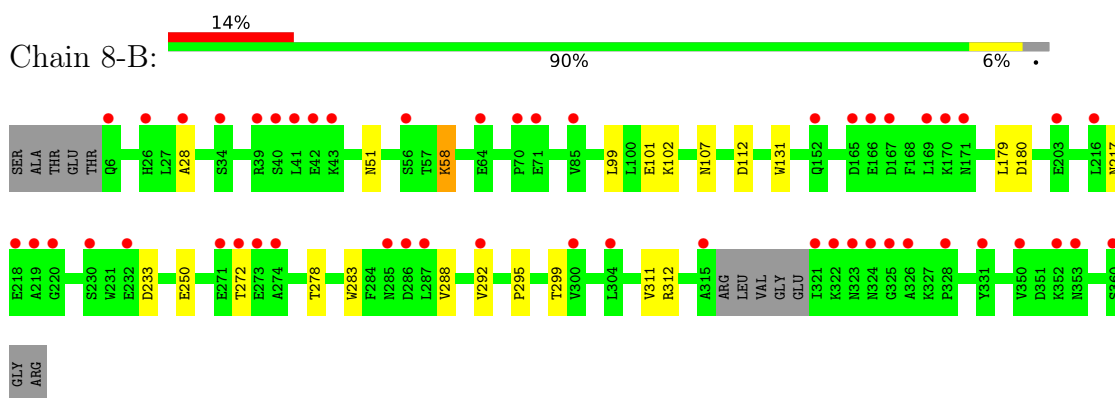

• Molecule 1: Probable oxidoreductase At4g09670

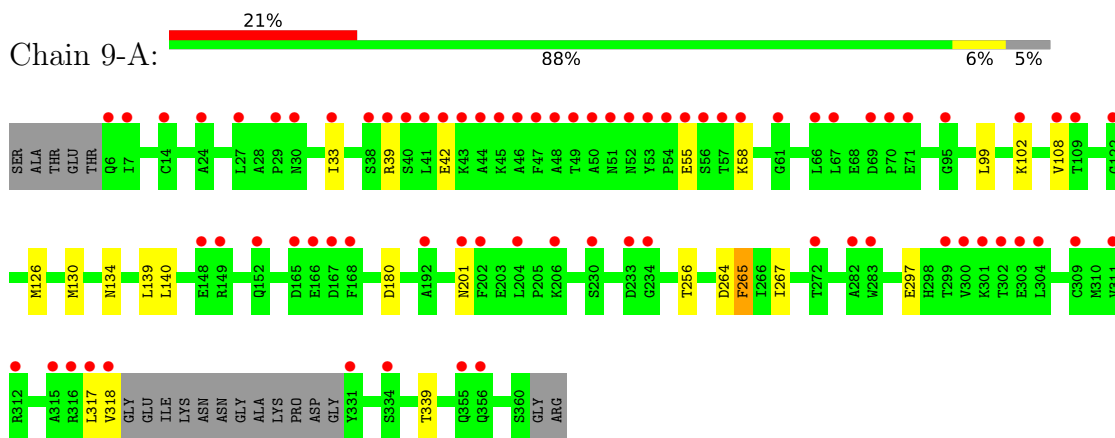

• Molecule 1: Probable oxidoreductase At4g09670

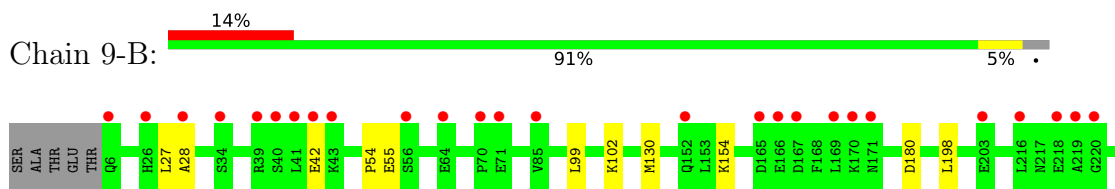

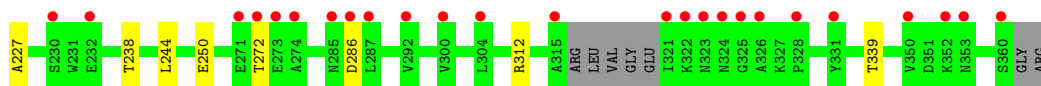

- Molecule 1: Probable oxidoreductase At4g09670

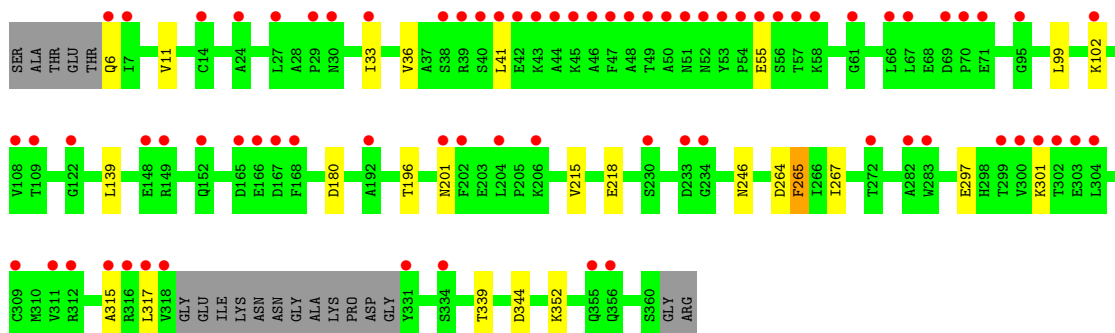
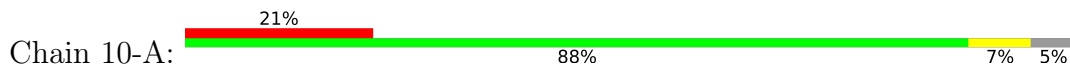

- Molecule 1: Probable oxidoreductase At4g09670

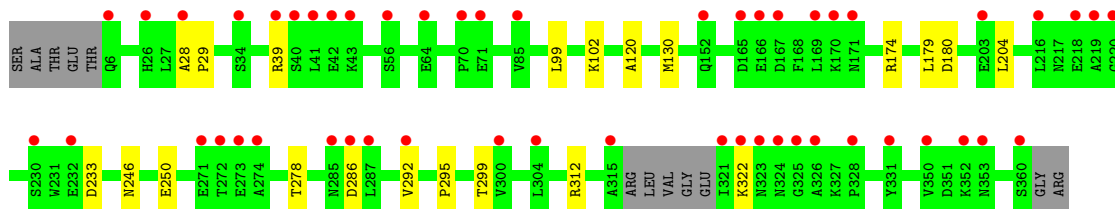

- Molecule 1: Probable oxidoreductase At4g09670

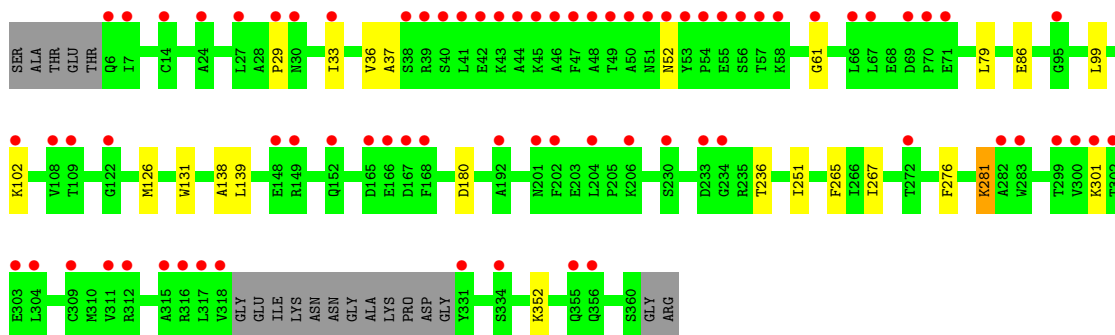
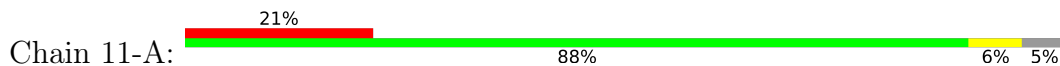

- Molecule 1: Probable oxidoreductase At4g09670

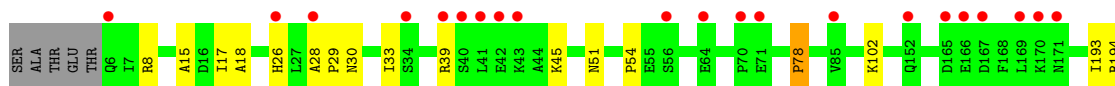
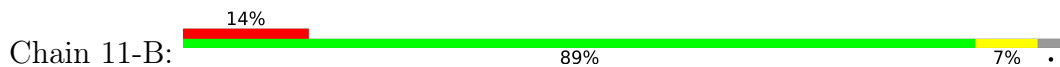

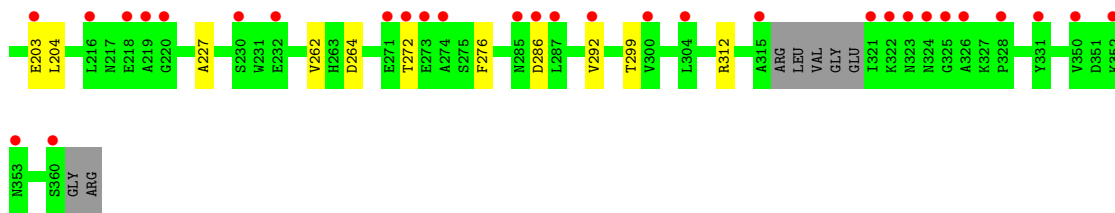

- Molecule 1: Probable oxidoreductase At4g09670

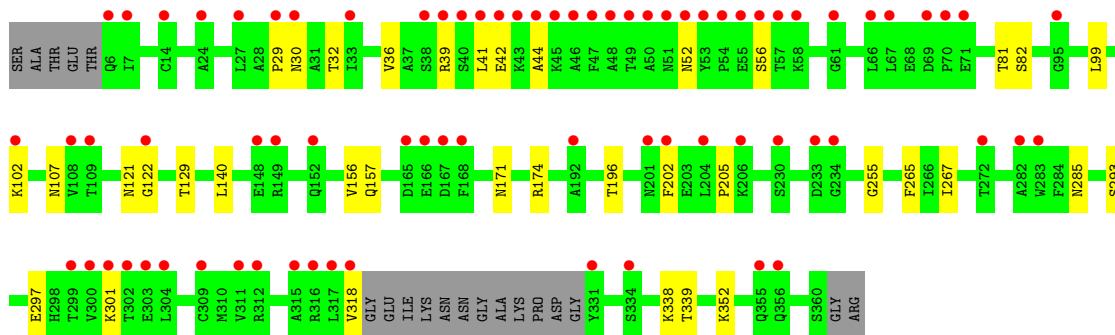
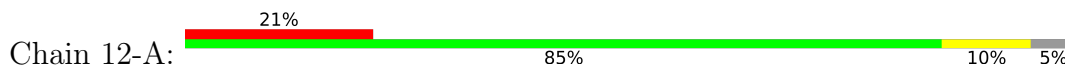

- Molecule 1: Probable oxidoreductase At4g09670

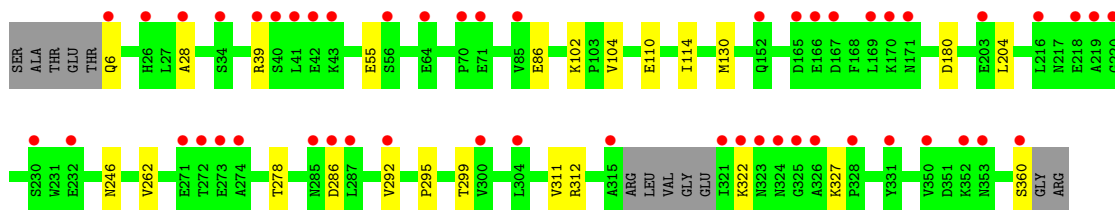

- Molecule 1: Probable oxidoreductase At4g09670

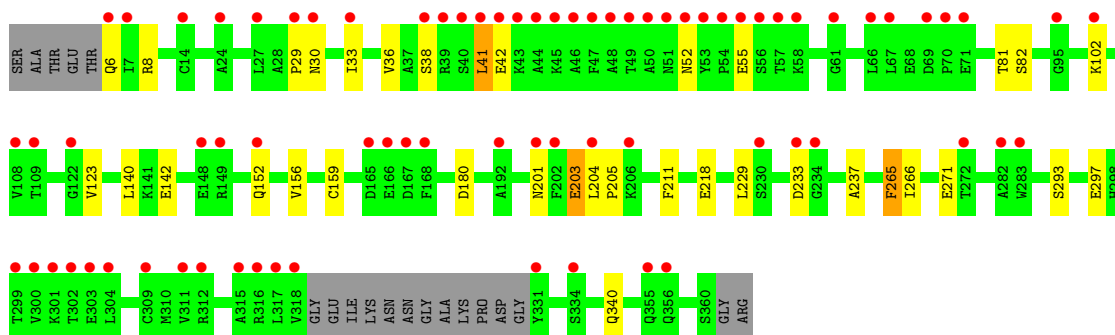
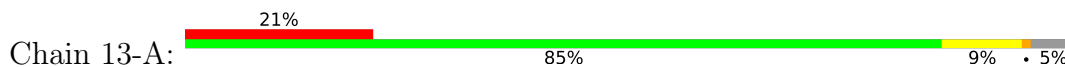

- Molecule 1: Probable oxidoreductase At4g09670

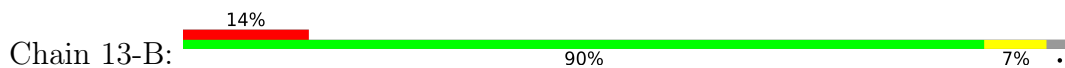

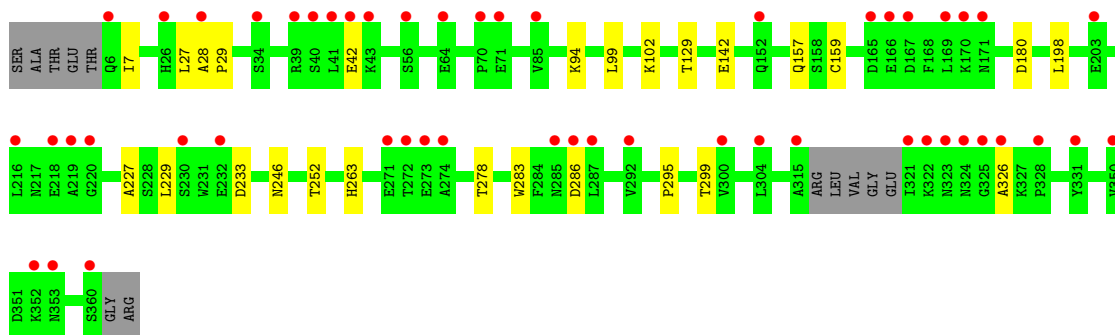

- Molecule 1: Probable oxidoreductase At4g09670

Chain 14-A: 21% 84% 10% 5%

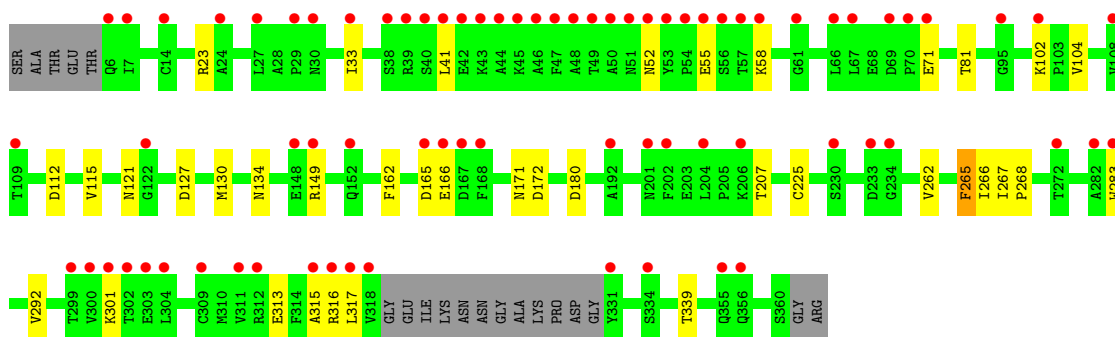

- Molecule 1: Probable oxidoreductase At4g09670

Chain 14-B: 14% 88% 9%

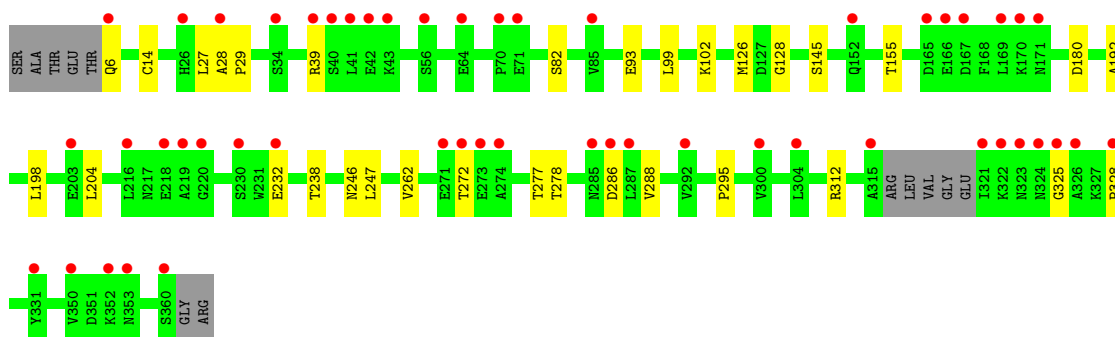

- Molecule 1: Probable oxidoreductase At4g09670

Chain 15-A: 21% 83% 12% 5%

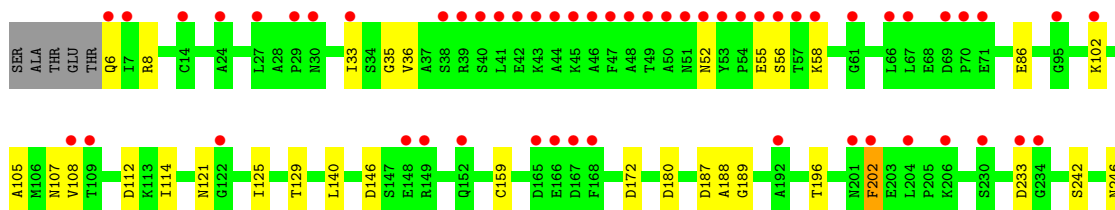

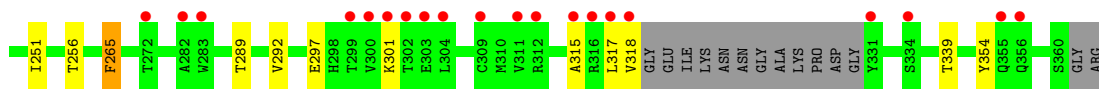

● Molecule 1: Probable oxidoreductase At4g09670

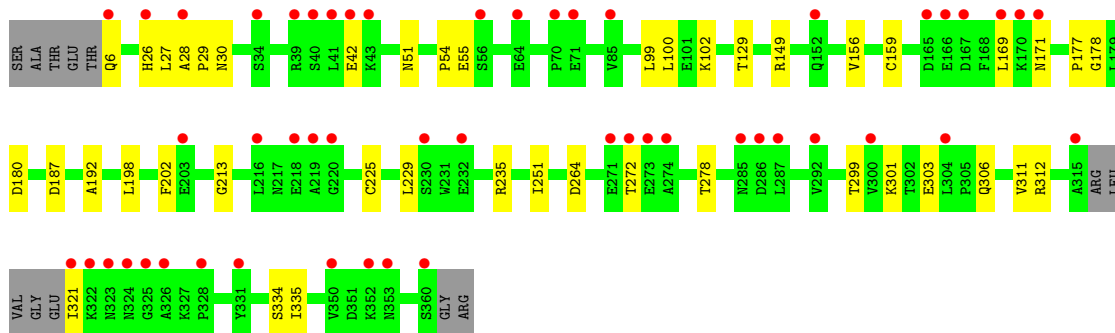
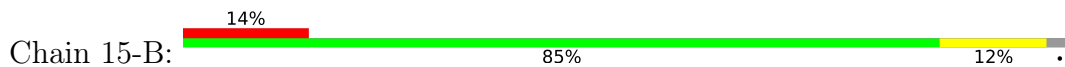

● Molecule 1: Probable oxidoreductase At4g09670

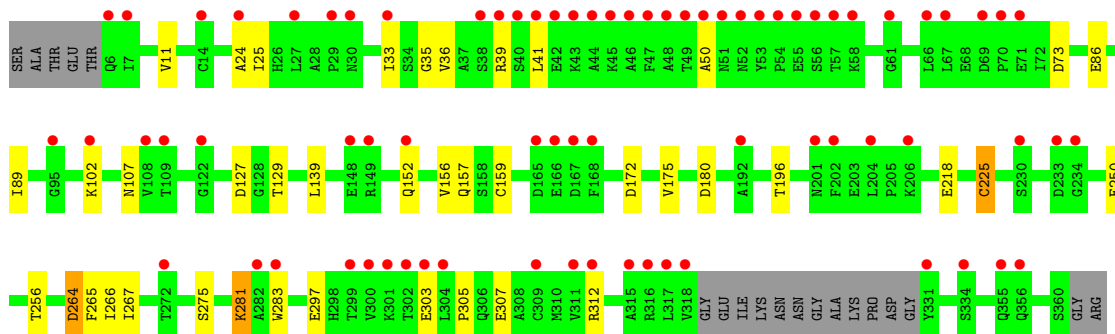
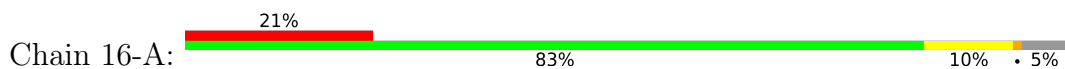

● Molecule 1: Probable oxidoreductase At4g09670

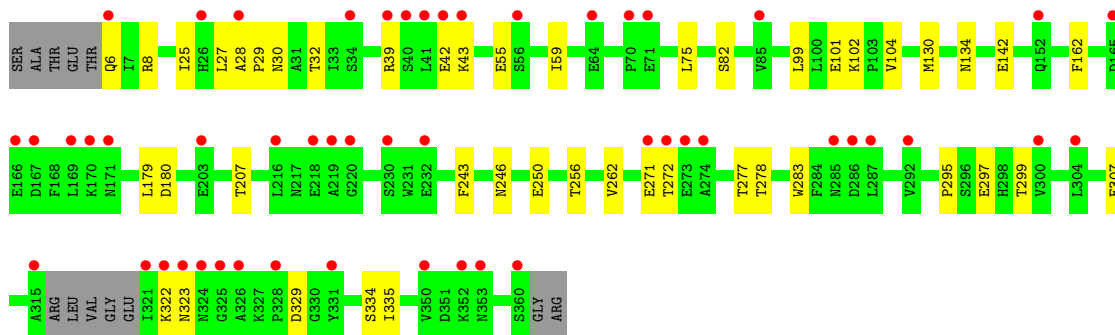
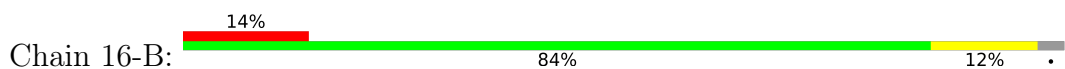

4 Data and refinement statistics

Property	Value	Source
Space group	P 21 21 21	Depositor
Cell constants a, b, c, α , β , γ	58.20Å 107.66Å 129.75Å 90.00° 90.00° 90.00°	Depositor
Resolution (Å)	29.73 – 2.49 29.73 – 2.49	Depositor EDS
% Data completeness (in resolution range)	98.4 (29.73-2.49) 98.4 (29.73-2.49)	Depositor EDS
R_{merge}	(Not available)	Depositor
R_{sym}	(Not available)	Depositor
$\langle I/\sigma(I) \rangle$ ¹	4.60 (at 2.48Å)	Xtrriage
Refinement program	CNS 1.1	Depositor
R, R_{free}	0.215 , 0.285 0.226 , 0.286	Depositor DCC
R_{free} test set	1472 reflections (5.10%)	wwPDB-VP
Wilson B-factor (Å ²)	36.7	Xtrriage
Anisotropy	0.414	Xtrriage
Bulk solvent k_{sol} (e/Å ³), B_{sol} (Å ²)	0.29 , 92.5	EDS
L-test for twinning ²	$\langle L \rangle = 0.47$, $\langle L^2 \rangle = 0.31$	Xtrriage
Estimated twinning fraction	No twinning to report.	Xtrriage
F_o, F_c correlation	0.90	EDS
Total number of atoms	87408	wwPDB-VP
Average B, all atoms (Å ²)	34.0	wwPDB-VP

Xtrriage's analysis on translational NCS is as follows: *The largest off-origin peak in the Patterson function is 19.72% of the height of the origin peak. No significant pseudotranslation is detected.*

¹Intensities estimated from amplitudes.

²Theoretical values of $\langle |L| \rangle$, $\langle L^2 \rangle$ for acentric reflections are 0.5, 0.333 respectively for untwinned datasets, and 0.375, 0.2 for perfectly twinned datasets.

5 Model quality

5.1 Standard geometry

The Z score for a bond length (or angle) is the number of standard deviations the observed value is removed from the expected value. A bond length (or angle) with $|Z| > 5$ is considered an outlier worth inspection. RMSZ is the root-mean-square of all Z scores of the bond lengths (or angles).

Mol	Chain	Bond lengths		Bond angles	
		RMSZ	# Z >5	RMSZ	# Z >5
1	1-A	0.34	0/2698	0.59	0/3656
1	1-B	0.35	0/2743	0.60	1/3716 (0.0%)
1	2-A	0.33	0/2698	0.57	0/3656
1	2-B	0.35	0/2743	0.60	0/3716
1	3-A	0.33	0/2698	0.59	0/3656
1	3-B	0.34	0/2743	0.58	0/3716
1	4-A	0.34	0/2698	0.59	0/3656
1	4-B	0.34	0/2743	0.60	0/3716
1	5-A	0.34	0/2698	0.59	0/3656
1	5-B	0.34	0/2743	0.58	0/3716
1	6-A	0.34	0/2698	0.59	0/3656
1	6-B	0.35	0/2743	0.60	1/3716 (0.0%)
1	7-A	0.33	0/2698	0.56	0/3656
1	7-B	0.34	0/2743	0.59	0/3716
1	8-A	0.34	0/2698	0.59	0/3656
1	8-B	0.35	0/2743	0.60	0/3716
1	9-A	0.33	0/2698	0.59	0/3656
1	9-B	0.35	0/2743	0.60	0/3716
1	10-A	0.34	0/2698	0.58	0/3656
1	10-B	0.35	0/2743	0.59	0/3716
1	11-A	0.34	0/2698	0.58	0/3656
1	11-B	0.35	0/2743	0.60	0/3716
1	12-A	0.34	0/2698	0.58	0/3656
1	12-B	0.34	0/2743	0.59	0/3716
1	13-A	0.36	0/2698	0.62	0/3656
1	13-B	0.37	0/2743	0.65	1/3716 (0.0%)
1	14-A	0.36	0/2698	0.62	0/3656
1	14-B	0.38	0/2743	0.64	1/3716 (0.0%)
1	15-A	0.37	0/2698	0.63	0/3656
1	15-B	0.38	0/2743	0.66	1/3716 (0.0%)
1	16-A	0.37	0/2698	0.62	0/3656
1	16-B	0.38	0/2743	0.63	1/3716 (0.0%)
All	All	0.35	0/87056	0.60	6/117952 (0.0%)

There are no bond length outliers.

The worst 5 of 6 bond angle outliers are listed below:

Mol	Chain	Res	Type	Atoms	Z	Observed(°)	Ideal(°)
1	15-B	27	LEU	N-CA-C	-6.95	92.23	111.00
1	16-B	27	LEU	N-CA-C	-6.42	93.67	111.00
1	13-B	27	LEU	N-CA-C	-5.91	95.04	111.00
1	14-B	27	LEU	N-CA-C	-5.71	95.58	111.00
1	6-B	27	LEU	N-CA-C	-5.42	96.37	111.00

There are no chirality outliers.

There are no planarity outliers.

5.2 Too-close contacts [i](#)

In the following table, the Non-H and H(model) columns list the number of non-hydrogen atoms and hydrogen atoms in the chain respectively. The H(added) column lists the number of hydrogen atoms added and optimized by MolProbity. The Clashes column lists the number of clashes within the asymmetric unit, whereas Symm-Clashes lists symmetry-related clashes.

Mol	Chain	Non-H	H(model)	H(added)	Clashes	Symm-Clashes
1	1-A	2648	0	2642	0	0
1	1-B	2692	0	2680	0	0
1	2-A	2648	0	2642	0	0
1	2-B	2692	0	2680	0	0
1	3-A	2648	0	2642	0	0
1	3-B	2692	0	2680	0	0
1	4-A	2648	0	2642	0	0
1	4-B	2692	0	2680	0	0
1	5-A	2648	0	2642	0	0
1	5-B	2692	0	2680	0	0
1	6-A	2648	0	2642	0	0
1	6-B	2692	0	2680	0	0
1	7-A	2648	0	2642	0	0
1	7-B	2692	0	2680	0	0
1	8-A	2648	0	2642	0	0
1	8-B	2692	0	2680	0	0
1	9-A	2648	0	2642	0	0
1	9-B	2692	0	2680	0	0
1	10-A	2648	0	2642	0	0
1	10-B	2692	0	2680	0	0
1	11-A	2648	0	2642	0	0
1	11-B	2692	0	2680	0	0

Continued on next page...

Continued from previous page...

Mol	Chain	Non-H	H(model)	H(added)	Clashes	Symm-Clashes
1	12-A	2648	0	2642	0	0
1	12-B	2692	0	2680	0	0
1	13-A	2648	0	2642	0	0
1	13-B	2692	0	2680	0	0
1	14-A	2648	0	2642	0	0
1	14-B	2692	0	2680	0	0
1	15-A	2648	0	2642	0	0
1	15-B	2692	0	2680	0	0
1	16-A	2648	0	2642	0	0
1	16-B	2692	0	2680	0	0
2	1-A	60	0	0	0	0
2	1-B	63	0	0	0	0
2	2-A	58	0	0	0	0
2	2-B	65	0	0	0	0
2	3-A	62	0	0	0	0
2	3-B	61	0	0	0	0
2	4-A	60	0	0	0	0
2	4-B	63	0	0	0	0
2	5-A	59	0	0	0	0
2	5-B	64	0	0	0	0
2	6-A	60	0	0	0	0
2	6-B	63	0	0	0	0
2	7-A	61	0	0	0	0
2	7-B	62	0	0	0	0
2	8-A	56	0	0	0	0
2	8-B	67	0	0	0	0
2	9-A	60	0	0	0	0
2	9-B	63	0	0	0	0
2	10-A	59	0	0	0	0
2	10-B	64	0	0	0	0
2	11-A	60	0	0	0	0
2	11-B	63	0	0	0	0
2	12-A	61	0	0	0	0
2	12-B	62	0	0	0	0
2	13-A	62	0	0	0	0
2	13-B	61	0	0	0	0
2	14-A	59	0	0	0	0
2	14-B	64	0	0	0	0
2	15-A	59	0	0	0	0
2	15-B	64	0	0	0	0
2	16-A	60	0	0	0	0
2	16-B	63	0	0	0	0

Continued on next page...

Continued from previous page...

Mol	Chain	Non-H	H(model)	H(added)	Clashes	Symm-Clashes
All	All	87408	0	85152	0	0

The all-atom clashscore is defined as the number of clashes found per 1000 atoms (including hydrogen atoms). Clashscore could not be calculated for this entry.

There are no clashes within the asymmetric unit.

There are no symmetry-related clashes.

5.3 Torsion angles [i](#)

5.3.1 Protein backbone [i](#)

In the following table, the Percentiles column shows the percent Ramachandran outliers of the chain as a percentile score with respect to all X-ray entries followed by that with respect to entries of similar resolution.

The Analysed column shows the number of residues for which the backbone conformation was analysed, and the total number of residues.

Mol	Chain	Analysed	Favoured	Allowed	Outliers	Percentiles
1	1-A	339/362 (94%)	294 (87%)	37 (11%)	8 (2%)	6 9
1	1-B	346/362 (96%)	300 (87%)	36 (10%)	10 (3%)	4 6
1	2-A	339/362 (94%)	300 (88%)	34 (10%)	5 (2%)	10 18
1	2-B	346/362 (96%)	307 (89%)	32 (9%)	7 (2%)	7 12
1	3-A	339/362 (94%)	276 (81%)	49 (14%)	14 (4%)	3 3
1	3-B	346/362 (96%)	286 (83%)	52 (15%)	8 (2%)	6 10
1	4-A	339/362 (94%)	287 (85%)	37 (11%)	15 (4%)	2 3
1	4-B	346/362 (96%)	315 (91%)	26 (8%)	5 (1%)	11 20
1	5-A	339/362 (94%)	295 (87%)	37 (11%)	7 (2%)	7 11
1	5-B	346/362 (96%)	298 (86%)	37 (11%)	11 (3%)	4 5
1	6-A	339/362 (94%)	298 (88%)	35 (10%)	6 (2%)	8 14
1	6-B	346/362 (96%)	309 (89%)	29 (8%)	8 (2%)	6 10
1	7-A	339/362 (94%)	291 (86%)	37 (11%)	11 (3%)	4 5
1	7-B	346/362 (96%)	294 (85%)	40 (12%)	12 (4%)	3 4
1	8-A	339/362 (94%)	280 (83%)	48 (14%)	11 (3%)	4 5
1	8-B	346/362 (96%)	303 (88%)	37 (11%)	6 (2%)	9 16

Continued on next page...

Continued from previous page...

Mol	Chain	Analysed	Favoured	Allowed	Outliers	Percentiles	
1	9-A	339/362 (94%)	299 (88%)	37 (11%)	3 (1%)	17	31
1	9-B	346/362 (96%)	309 (89%)	32 (9%)	5 (1%)	11	20
1	10-A	339/362 (94%)	294 (87%)	37 (11%)	8 (2%)	6	9
1	10-B	346/362 (96%)	296 (86%)	40 (12%)	10 (3%)	4	6
1	11-A	339/362 (94%)	284 (84%)	44 (13%)	11 (3%)	4	5
1	11-B	346/362 (96%)	288 (83%)	43 (12%)	15 (4%)	2	3
1	12-A	339/362 (94%)	272 (80%)	49 (14%)	18 (5%)	2	2
1	12-B	346/362 (96%)	294 (85%)	46 (13%)	6 (2%)	9	16
1	13-A	339/362 (94%)	281 (83%)	43 (13%)	15 (4%)	2	3
1	13-B	346/362 (96%)	309 (89%)	27 (8%)	10 (3%)	4	6
1	14-A	339/362 (94%)	288 (85%)	36 (11%)	15 (4%)	2	3
1	14-B	346/362 (96%)	302 (87%)	33 (10%)	11 (3%)	4	5
1	15-A	339/362 (94%)	265 (78%)	53 (16%)	21 (6%)	1	1
1	15-B	346/362 (96%)	282 (82%)	48 (14%)	16 (5%)	2	2
1	16-A	339/362 (94%)	270 (80%)	50 (15%)	19 (6%)	2	1
1	16-B	346/362 (96%)	291 (84%)	42 (12%)	13 (4%)	3	4
All	All	10960/11584 (95%)	9357 (85%)	1263 (12%)	340 (3%)	4	5

5 of 340 Ramachandran outliers are listed below:

Mol	Chain	Res	Type
1	1-A	140	LEU
1	1-A	317	LEU
1	1-B	28	ALA
1	1-B	179	LEU
1	1-B	246	ASN

5.3.2 Protein sidechains [i](#)

In the following table, the Percentiles column shows the percent sidechain outliers of the chain as a percentile score with respect to all X-ray entries followed by that with respect to entries of similar resolution.

The Analysed column shows the number of residues for which the sidechain conformation was analysed, and the total number of residues.

Mol	Chain	Analysed	Rotameric	Outliers	Percentiles	
1	1-A	286/293 (98%)	266 (93%)	20 (7%)	15	29
1	1-B	290/293 (99%)	276 (95%)	14 (5%)	25	48
1	2-A	286/293 (98%)	269 (94%)	17 (6%)	19	37
1	2-B	290/293 (99%)	280 (97%)	10 (3%)	37	63
1	3-A	286/293 (98%)	263 (92%)	23 (8%)	12	23
1	3-B	290/293 (99%)	275 (95%)	15 (5%)	23	44
1	4-A	286/293 (98%)	267 (93%)	19 (7%)	16	32
1	4-B	290/293 (99%)	280 (97%)	10 (3%)	37	63
1	5-A	286/293 (98%)	268 (94%)	18 (6%)	18	34
1	5-B	290/293 (99%)	278 (96%)	12 (4%)	30	55
1	6-A	286/293 (98%)	270 (94%)	16 (6%)	21	40
1	6-B	290/293 (99%)	277 (96%)	13 (4%)	27	51
1	7-A	286/293 (98%)	264 (92%)	22 (8%)	13	25
1	7-B	290/293 (99%)	276 (95%)	14 (5%)	25	48
1	8-A	286/293 (98%)	273 (96%)	13 (4%)	27	51
1	8-B	290/293 (99%)	272 (94%)	18 (6%)	18	35
1	9-A	286/293 (98%)	265 (93%)	21 (7%)	14	27
1	9-B	290/293 (99%)	276 (95%)	14 (5%)	25	48
1	10-A	286/293 (98%)	268 (94%)	18 (6%)	18	34
1	10-B	290/293 (99%)	279 (96%)	11 (4%)	33	58
1	11-A	286/293 (98%)	273 (96%)	13 (4%)	27	51
1	11-B	290/293 (99%)	276 (95%)	14 (5%)	25	48
1	12-A	286/293 (98%)	267 (93%)	19 (7%)	16	32
1	12-B	290/293 (99%)	272 (94%)	18 (6%)	18	35
1	13-A	286/293 (98%)	262 (92%)	24 (8%)	11	21
1	13-B	290/293 (99%)	275 (95%)	15 (5%)	23	44
1	14-A	286/293 (98%)	262 (92%)	24 (8%)	11	21
1	14-B	290/293 (99%)	270 (93%)	20 (7%)	15	30
1	15-A	286/293 (98%)	261 (91%)	25 (9%)	10	20
1	15-B	290/293 (99%)	264 (91%)	26 (9%)	9	19
1	16-A	286/293 (98%)	261 (91%)	25 (9%)	10	20
1	16-B	290/293 (99%)	259 (89%)	31 (11%)	6	13

Continued on next page...

Continued from previous page...

Mol	Chain	Analysed	Rotameric	Outliers	Percentiles
All	All	9216/9376 (98%)	8644 (94%)	572 (6%)	18 35

5 of 572 residues with a non-rotameric sidechain are listed below:

Mol	Chain	Res	Type
1	14-B	278	THR
1	15-A	146	ASP
1	14-B	277	THR
1	16-A	73	ASP
1	7-A	102	LYS

Sometimes sidechains can be flipped to improve hydrogen bonding and reduce clashes. 5 of 116 such sidechains are listed below:

Mol	Chain	Res	Type
1	9-B	152	GLN
1	16-B	6	GLN
1	11-B	51	ASN
1	16-A	356	GLN
1	15-B	133	HIS

5.3.3 RNA [i](#)

There are no RNA molecules in this entry.

5.4 Non-standard residues in protein, DNA, RNA chains [i](#)

There are no non-standard protein/DNA/RNA residues in this entry.

5.5 Carbohydrates [i](#)

There are no monosaccharides in this entry.

5.6 Ligand geometry [i](#)

There are no ligands in this entry.

5.7 Other polymers [i](#)

There are no such residues in this entry.

5.8 Polymer linkage issues [i](#)

There are no chain breaks in this entry.

6 Fit of model and data [i](#)

6.1 Protein, DNA and RNA chains [i](#)

In the following table, the column labelled '#RSRZ > 2' contains the number (and percentage) of RSRZ outliers, followed by percent RSRZ outliers for the chain as percentile scores relative to all X-ray entries and entries of similar resolution. The OWAB column contains the minimum, median, 95th percentile and maximum values of the occupancy-weighted average B-factor per residue. The column labelled 'Q < 0.9' lists the number of (and percentage) of residues with an average occupancy less than 0.9.

Mol	Chain	Analysed	<RSRZ>	#RSRZ>2	OWAB(Å ²)	Q<0.9
1	1-A	337/362 (93%)	1.12	75 (22%) 0 0	15, 33, 53, 80	337 (100%)
1	1-B	344/362 (95%)	0.86	51 (14%) 2 2	16, 31, 46, 53	344 (100%)
1	2-A	337/362 (93%)	1.12	75 (22%) 0 0	15, 33, 53, 80	337 (100%)
1	2-B	344/362 (95%)	0.86	51 (14%) 2 2	16, 31, 46, 53	344 (100%)
1	3-A	337/362 (93%)	1.12	75 (22%) 0 0	15, 33, 53, 80	337 (100%)
1	3-B	344/362 (95%)	0.86	51 (14%) 2 2	16, 31, 46, 53	344 (100%)
1	4-A	337/362 (93%)	1.12	75 (22%) 0 0	15, 33, 53, 80	337 (100%)
1	4-B	344/362 (95%)	0.86	51 (14%) 2 2	16, 31, 46, 53	344 (100%)
1	5-A	337/362 (93%)	1.12	75 (22%) 0 0	15, 33, 53, 80	337 (100%)
1	5-B	344/362 (95%)	0.86	51 (14%) 2 2	16, 31, 46, 53	344 (100%)
1	6-A	337/362 (93%)	1.12	75 (22%) 0 0	15, 33, 53, 80	337 (100%)
1	6-B	344/362 (95%)	0.86	51 (14%) 2 2	16, 31, 46, 53	344 (100%)
1	7-A	337/362 (93%)	1.12	75 (22%) 0 0	15, 33, 53, 80	337 (100%)
1	7-B	344/362 (95%)	0.86	51 (14%) 2 2	16, 31, 46, 53	344 (100%)
1	8-A	337/362 (93%)	1.12	75 (22%) 0 0	15, 33, 53, 80	337 (100%)
1	8-B	344/362 (95%)	0.86	51 (14%) 2 2	16, 31, 46, 53	344 (100%)
1	9-A	337/362 (93%)	1.12	75 (22%) 0 0	15, 33, 53, 80	337 (100%)
1	9-B	344/362 (95%)	0.86	51 (14%) 2 2	16, 31, 46, 53	344 (100%)
1	10-A	337/362 (93%)	1.12	75 (22%) 0 0	15, 33, 53, 80	337 (100%)
1	10-B	344/362 (95%)	0.86	51 (14%) 2 2	16, 31, 46, 53	344 (100%)
1	11-A	337/362 (93%)	1.12	75 (22%) 0 0	15, 33, 53, 80	337 (100%)
1	11-B	344/362 (95%)	0.86	51 (14%) 2 2	16, 31, 46, 53	344 (100%)
1	12-A	337/362 (93%)	1.12	75 (22%) 0 0	15, 33, 53, 80	337 (100%)
1	12-B	344/362 (95%)	0.86	51 (14%) 2 2	16, 31, 46, 53	344 (100%)

Continued on next page...

Continued from previous page...

Mol	Chain	Analysed	<RSRZ>	#RSRZ>2	OWAB(Å ²)	Q<0.9
1	13-A	337/362 (93%)	1.12	75 (22%) 0 0	15, 33, 53, 80	337 (100%)
1	13-B	344/362 (95%)	0.86	51 (14%) 2 2	16, 31, 46, 53	344 (100%)
1	14-A	337/362 (93%)	1.12	75 (22%) 0 0	15, 33, 53, 80	337 (100%)
1	14-B	344/362 (95%)	0.86	51 (14%) 2 2	16, 31, 46, 53	344 (100%)
1	15-A	337/362 (93%)	1.12	75 (22%) 0 0	15, 33, 53, 80	337 (100%)
1	15-B	344/362 (95%)	0.86	51 (14%) 2 2	16, 31, 46, 53	344 (100%)
1	16-A	337/362 (93%)	1.12	75 (22%) 0 0	15, 33, 53, 80	337 (100%)
1	16-B	344/362 (95%)	0.86	51 (14%) 2 2	16, 31, 46, 53	344 (100%)
All	All	10896/11584 (94%)	0.99	2016 (18%) 1 1	15, 32, 51, 80	10896 (100%)

The worst 5 of 2016 RSRZ outliers are listed below:

Mol	Chain	Res	Type	RSRZ
1	1-A	317	LEU	9.4
1	2-A	317	LEU	9.4
1	3-A	317	LEU	9.4
1	4-A	317	LEU	9.4
1	5-A	317	LEU	9.4

6.2 Non-standard residues in protein, DNA, RNA chains [i](#)

There are no non-standard protein/DNA/RNA residues in this entry.

6.3 Carbohydrates [i](#)

There are no monosaccharides in this entry.

6.4 Ligands [i](#)

There are no ligands in this entry.

6.5 Other polymers [i](#)

There are no such residues in this entry.