



Full wwPDB X-ray Structure Validation Report ⓘ

Oct 18, 2023 – 11:21 AM EDT

PDB ID : 1YE9
Title : Crystal structure of proteolytically truncated catalase HPII from E. coli
Authors : Loewen, P.C.; Chelikani, P.; Carpena, X.; Fita, I.; Perez-Luque, R.; Donald, L.J.; Switala, J.; Duckworth, H.W.
Deposited on : 2004-12-28
Resolution : 2.80 Å(reported)

This is a Full wwPDB X-ray Structure Validation Report for a publicly released PDB entry.

We welcome your comments at validation@mail.wwpdb.org

A user guide is available at

<https://www.wwpdb.org/validation/2017/XrayValidationReportHelp>

with specific help available everywhere you see the ⓘ symbol.

The types of validation reports are described at

<http://www.wwpdb.org/validation/2017/FAQs#types>.

The following versions of software and data (see [references ⓘ](#)) were used in the production of this report:

MolProbity : 4.02b-467
Mogul : 1.8.5 (274361), CSD as541be (2020)
Xtriage (Phenix) : 1.13
EDS : 2.36
buster-report : 1.1.7 (2018)
Percentile statistics : 20191225.v01 (using entries in the PDB archive December 25th 2019)
Refmac : 5.8.0158
CCP4 : 7.0.044 (Gargrove)
Ideal geometry (proteins) : Engh & Huber (2001)
Ideal geometry (DNA, RNA) : Parkinson et al. (1996)
Validation Pipeline (wwPDB-VP) : 2.36

1 Overall quality at a glance

The following experimental techniques were used to determine the structure:

X-RAY DIFFRACTION

The reported resolution of this entry is 2.80 Å.

Percentile scores (ranging between 0-100) for global validation metrics of the entry are shown in the following graphic. The table shows the number of entries on which the scores are based.

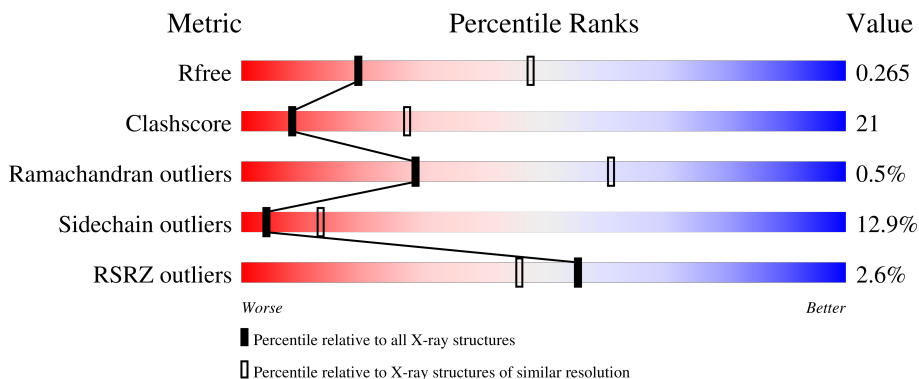







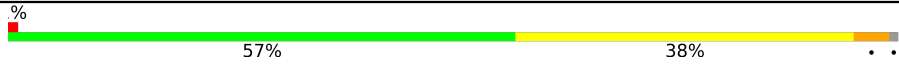

Metric	Whole archive (#Entries)	Similar resolution (#Entries, resolution range(Å))
R_{free}	130704	3140 (2.80-2.80)
Clashscore	141614	3569 (2.80-2.80)
Ramachandran outliers	138981	3498 (2.80-2.80)
Sidechain outliers	138945	3500 (2.80-2.80)
RSRZ outliers	127900	3078 (2.80-2.80)

The table below summarises the geometric issues observed across the polymeric chains and their fit to the electron density. The red, orange, yellow and green segments of the lower bar indicate the fraction of residues that contain outliers for ≥ 3 , 2, 1 and 0 types of geometric quality criteria respectively. A grey segment represents the fraction of residues that are not modelled. The numeric value for each fraction is indicated below the corresponding segment, with a dot representing fractions $\leq 5\%$. The upper red bar (where present) indicates the fraction of residues that have poor fit to the electron density. The numeric value is given above the bar.

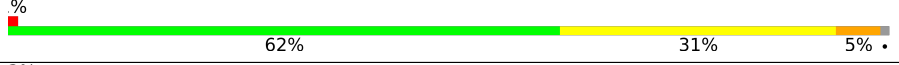
Mol	Chain	Length	Quality of chain
1	A	226	
1	B	226	
1	C	226	
1	D	226	
1	I	226	

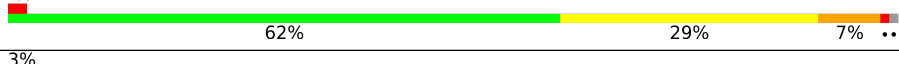
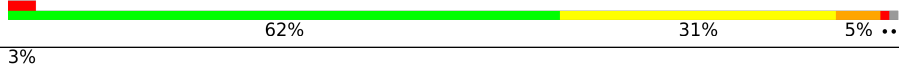
Continued on next page...

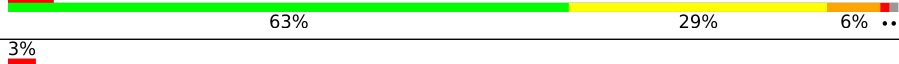
Continued from previous page...

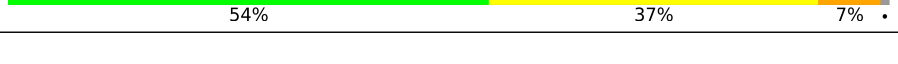
Mol	Chain	Length	Quality of chain
1	J	226	
1	K	226	
1	L	226	
2	E	259	
2	F	259	
2	G	259	
2	H	259	
2	M	259	
2	N	259	
2	O	259	
2	P	259	

The following table lists non-polymeric compounds, carbohydrate monomers and non-standard residues in protein, DNA, RNA chains that are outliers for geometric or electron-density-fit criteria:

Mol	Type	Chain	Res	Chirality	Geometry	Clashes	Electron density
3	HDD	F	760	-	-	X	-

2 Entry composition [i](#)

There are 4 unique types of molecules in this entry. The entry contains 31715 atoms, of which 0 are hydrogens and 0 are deuteriums.

In the tables below, the ZeroOcc column contains the number of atoms modelled with zero occupancy, the AltConf column contains the number of residues with at least one atom in alternate conformation and the Trace column contains the number of residues modelled with at most 2 atoms.

- Molecule 1 is a protein called catalase HPIL.

Mol	Chain	Residues	Atoms					ZeroOcc	AltConf	Trace
			Total	C	N	O	S			
1	A	223	Total 1796	C 1148	N 319	O 326	S 3	0	0	0
1	B	223	Total 1803	C 1152	N 322	O 326	S 3	0	1	0
1	C	223	Total 1800	C 1151	N 320	O 326	S 3	0	1	0
1	D	223	Total 1802	C 1151	N 322	O 326	S 3	0	1	0
1	I	223	Total 1796	C 1148	N 319	O 326	S 3	0	0	0
1	J	223	Total 1796	C 1148	N 319	O 326	S 3	0	0	0
1	K	223	Total 1796	C 1148	N 319	O 326	S 3	0	0	0
1	L	223	Total 1801	C 1150	N 322	O 326	S 3	0	1	0

- Molecule 2 is a protein called catalase HPIL.

Mol	Chain	Residues	Atoms					ZeroOcc	AltConf	Trace
			Total	C	N	O	S			
2	E	256	Total 2107	C 1340	N 370	O 393	S 4	0	3	0
2	F	256	Total 2094	C 1333	N 367	O 390	S 4	0	0	0
2	G	256	Total 2106	C 1340	N 372	O 390	S 4	0	2	0
2	H	256	Total 2100	C 1337	N 369	O 390	S 4	0	1	0
2	M	256	Total 2098	C 1336	N 368	O 390	S 4	0	1	0
2	N	256	Total 2100	C 1337	N 369	O 390	S 4	0	1	0

Continued on next page...

Continued from previous page...

Mol	Chain	Residues	Atoms					ZeroOcc	AltConf	Trace
2	O	256	Total	C	N	O	S	0	0	0
			2094	1333	367	390	4			
2	P	256	Total	C	N	O	S	0	0	0
			2094	1333	367	390	4			

- Molecule 3 is CIS-HEME D HYDROXYCHLORIN GAMMA-SPIROLACTONE (three-letter code: HDD) (formula: $C_{34}H_{32}FeN_4O_5$).

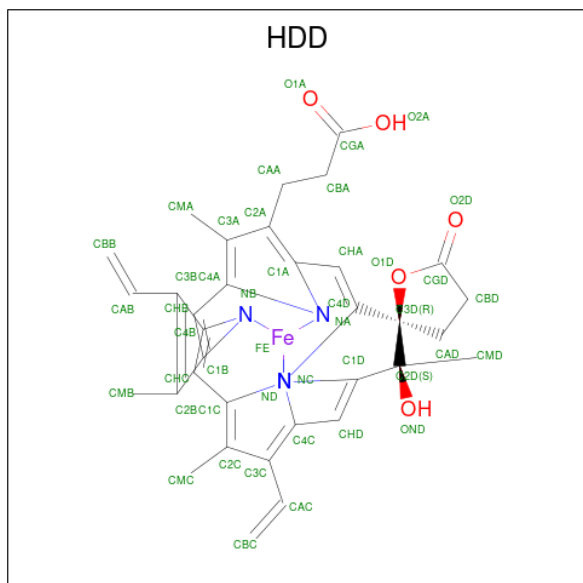

Mol	Chain	Residues	Atoms					ZeroOcc	AltConf
3	E	1	Total	C	Fe	N	O	0	0
			44	34	1	4	5		
3	F	1	Total	C	Fe	N	O	0	0
			44	34	1	4	5		
3	G	1	Total	C	Fe	N	O	0	0
			44	34	1	4	5		
3	H	1	Total	C	Fe	N	O	0	0
			44	34	1	4	5		
3	M	1	Total	C	Fe	N	O	0	0
			44	34	1	4	5		
3	N	1	Total	C	Fe	N	O	0	0
			44	34	1	4	5		
3	O	1	Total	C	Fe	N	O	0	0
			44	34	1	4	5		
3	P	1	Total	C	Fe	N	O	0	0
			44	34	1	4	5		

- Molecule 4 is water.

Mol	Chain	Residues	Atoms	ZeroOcc	AltConf
4	A	21	Total O 21 21	0	0
4	E	20	Total O 20 20	0	0
4	B	8	Total O 8 8	0	0
4	F	11	Total O 11 11	0	0
4	C	20	Total O 20 20	0	0
4	G	11	Total O 11 11	0	0
4	D	11	Total O 11 11	0	0
4	H	11	Total O 11 11	0	0
4	I	5	Total O 5 5	0	0
4	M	2	Total O 2 2	0	0
4	J	12	Total O 12 12	0	0
4	N	12	Total O 12 12	0	0
4	K	3	Total O 3 3	0	0
4	O	4	Total O 4 4	0	0
4	L	16	Total O 16 16	0	0
4	P	13	Total O 13 13	0	0

3 Residue-property plots [i](#)

These plots are drawn for all protein, RNA, DNA and oligosaccharide chains in the entry. The first graphic for a chain summarises the proportions of the various outlier classes displayed in the second graphic. The second graphic shows the sequence view annotated by issues in geometry and electron density. Residues are color-coded according to the number of geometric quality criteria for which they contain at least one outlier: green = 0, yellow = 1, orange = 2 and red = 3 or more. A red dot above a residue indicates a poor fit to the electron density ($RSRZ > 2$). Stretches of 2 or more consecutive residues without any outlier are shown as a green connector. Residues present in the sample, but not in the model, are shown in grey.

- Molecule 1: catalase HPII

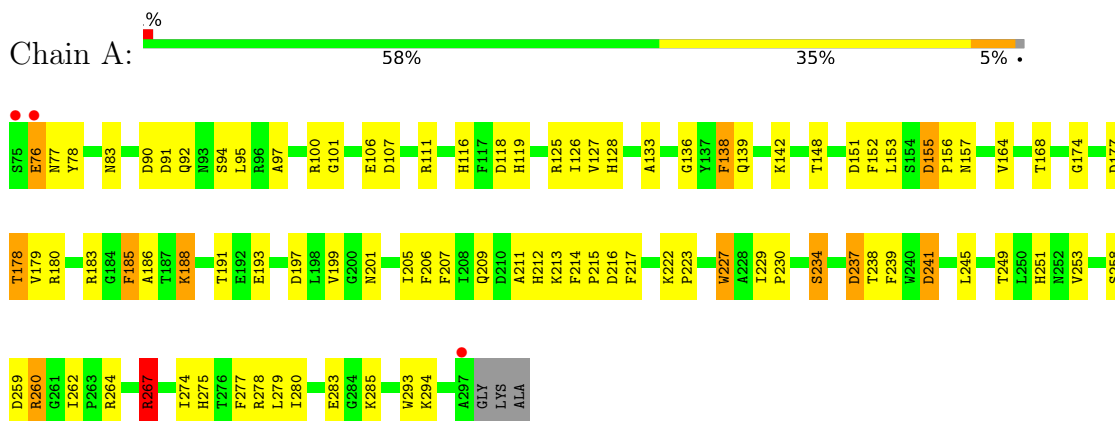

- Molecule 1: catalase HPII



- Molecule 1: catalase HPII

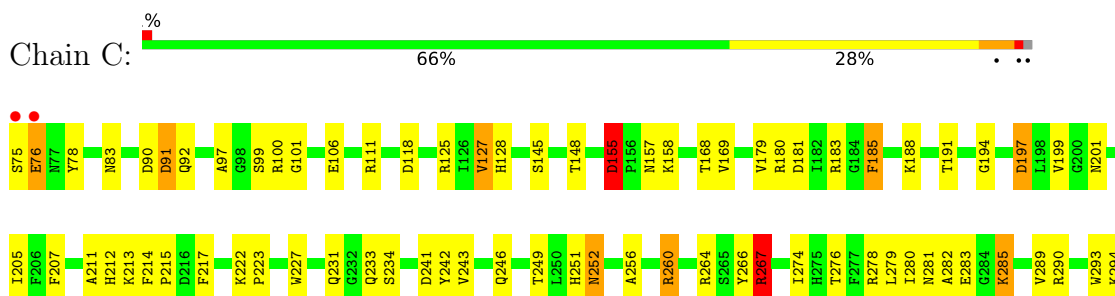

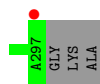

• Molecule 1: catalase HPII

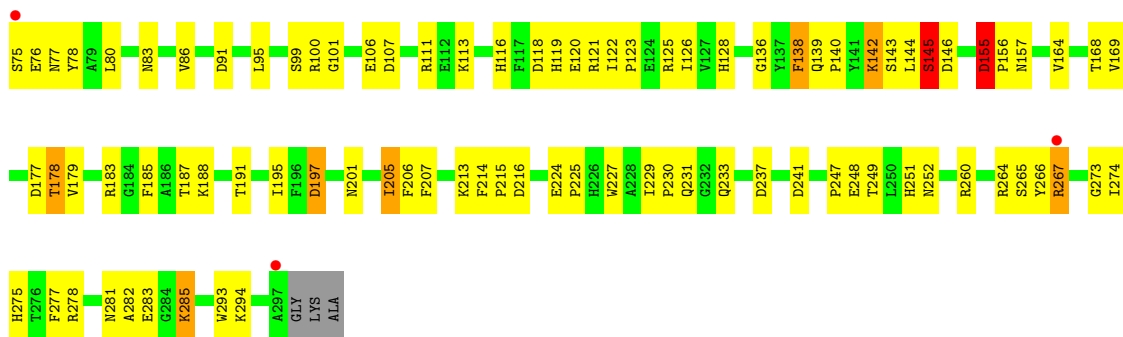

• Molecule 1: catalase HPII

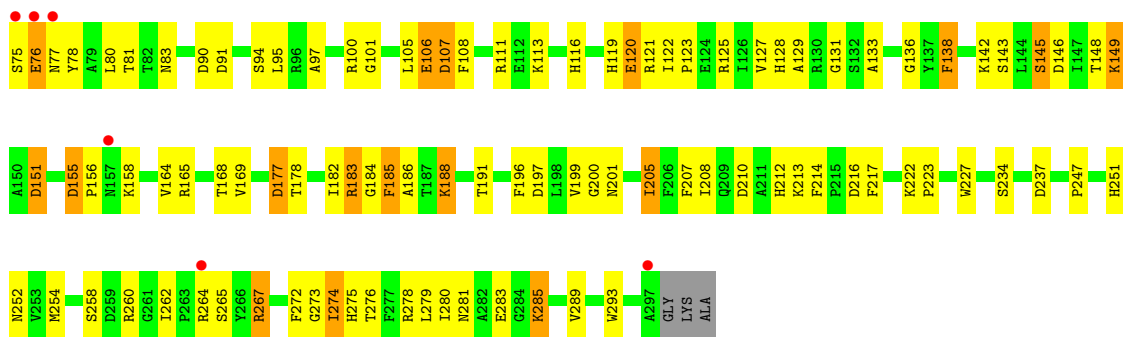

• Molecule 1: catalase HPII

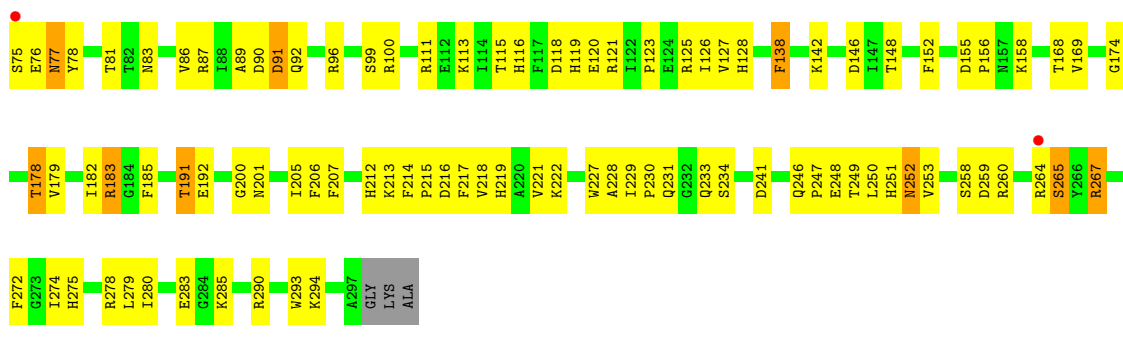

• Molecule 1: catalase HPII



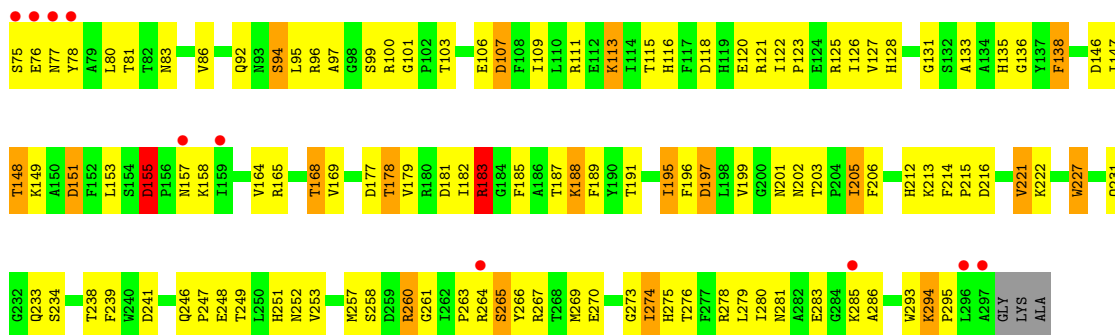

- Molecule 1: catalase HPII

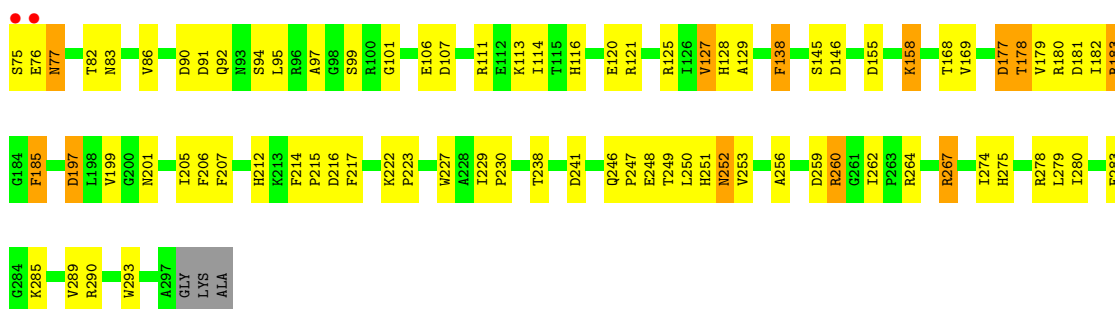

- Molecule 2: catalase HPII

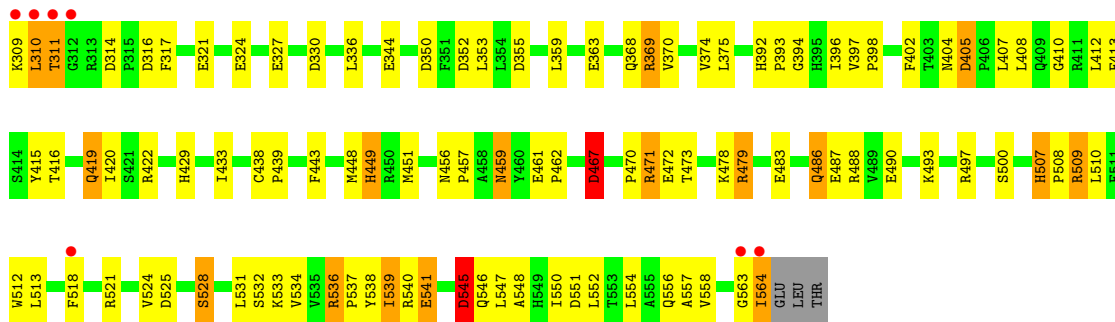

- Molecule 2: catalase HPII

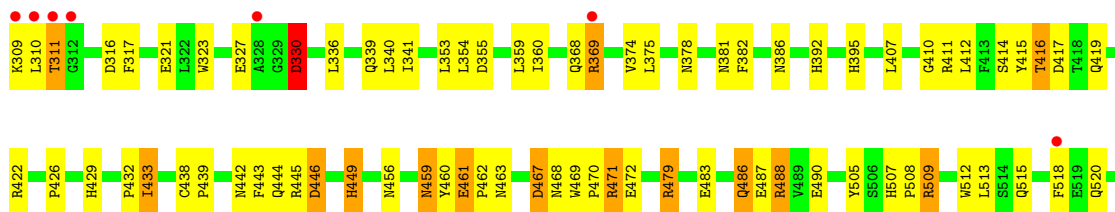



- Molecule 2: catalase HPII

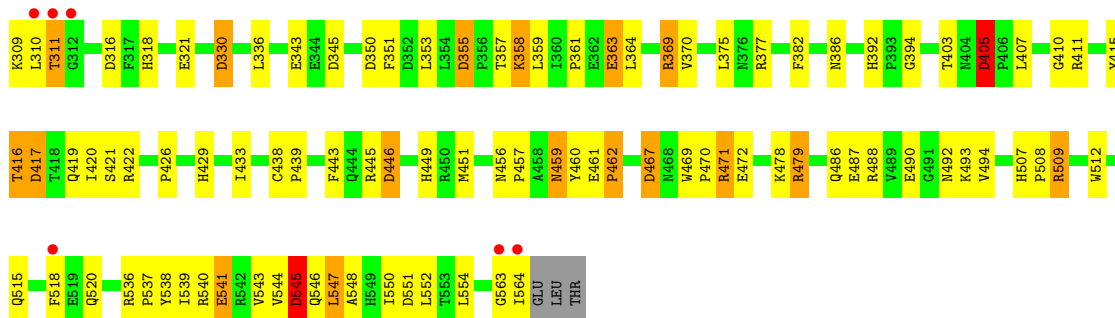

- Molecule 2: catalase HPII

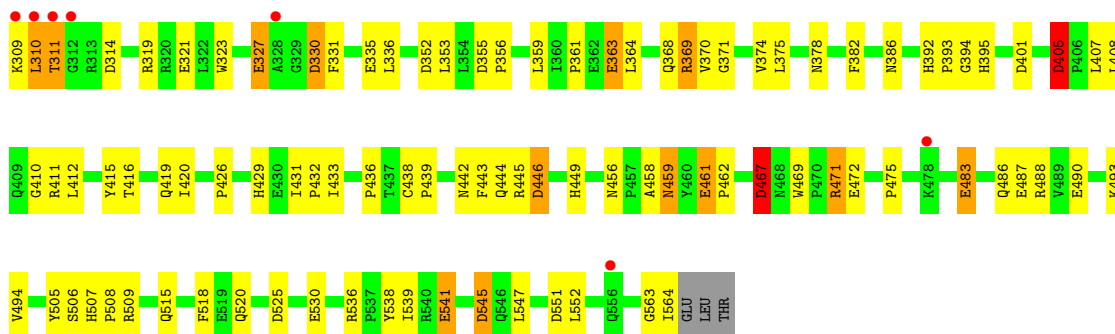

- Molecule 2: catalase HPII

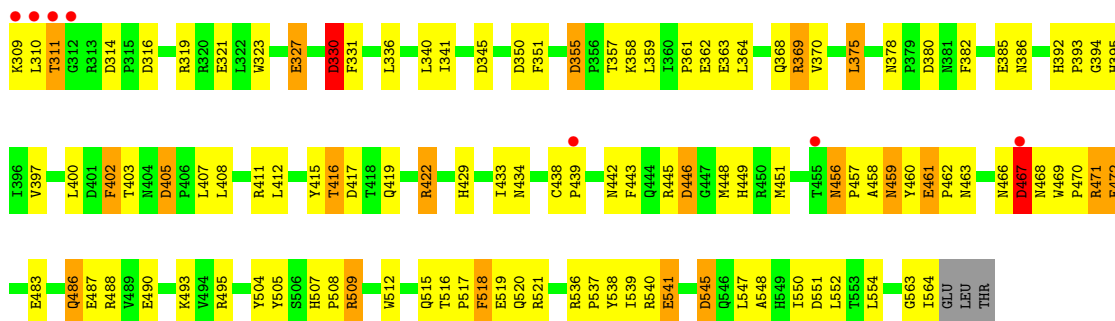

- Molecule 2: catalase HPII



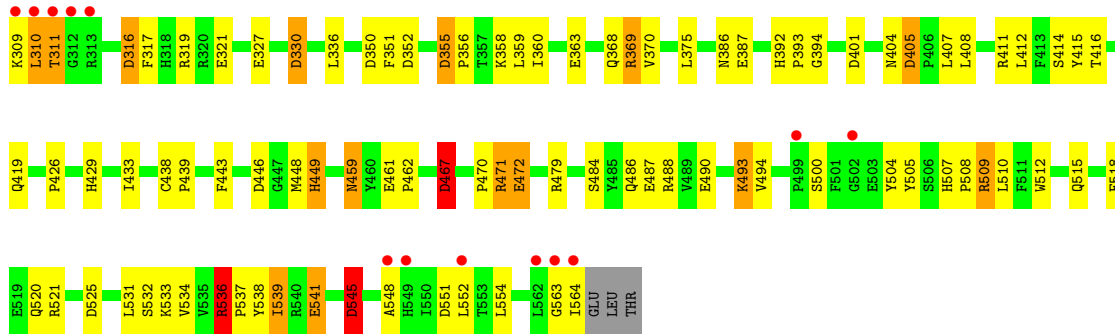

• Molecule 2: catalase HPII

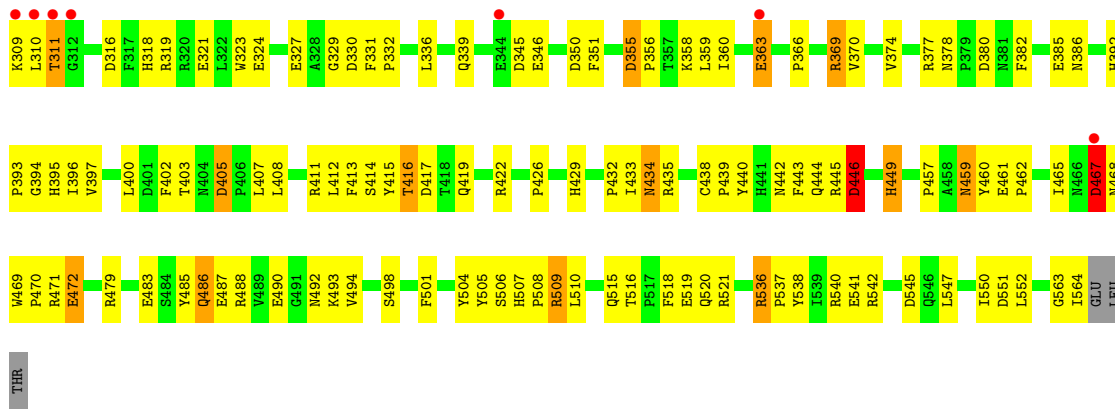

• Molecule 2: catalase HPII

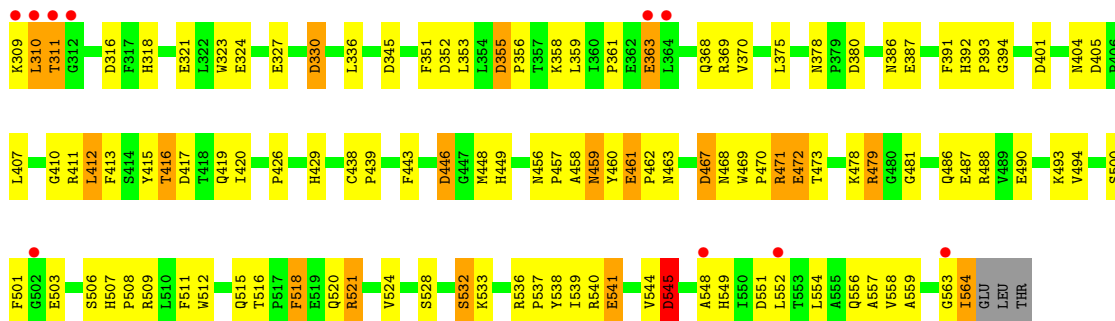

4 Data and refinement statistics

Property	Value	Source
Space group	P 1 21 1	Depositor
Cell constants a, b, c, α , β , γ	111.01Å 152.89Å 135.29Å 90.00° 97.54° 90.00°	Depositor
Resolution (Å)	30.00 – 2.80 29.95 – 2.80	Depositor EDS
% Data completeness (in resolution range)	100.0 (30.00-2.80) 95.4 (29.95-2.80)	Depositor EDS
R_{merge}	0.07	Depositor
R_{sym}	0.11	Depositor
$\langle I/\sigma(I) \rangle$ ¹	1.86 (at 2.80Å)	Xtrriage
Refinement program	REFMAC 5.1.24	Depositor
R, R_{free}	0.217 , 0.269 0.217 , 0.265	Depositor DCC
R_{free} test set	5289 reflections (5.04%)	wwPDB-VP
Wilson B-factor (Å ²)	51.6	Xtrriage
Anisotropy	0.139	Xtrriage
Bulk solvent k_{sol} (e/Å ³), B_{sol} (Å ²)	0.34 , 48.9	EDS
L-test for twinning ²	$\langle L \rangle = 0.45$, $\langle L^2 \rangle = 0.28$	Xtrriage
Estimated twinning fraction	No twinning to report.	Xtrriage
F_o, F_c correlation	0.91	EDS
Total number of atoms	31715	wwPDB-VP
Average B, all atoms (Å ²)	43.0	wwPDB-VP

Xtrriage's analysis on translational NCS is as follows: *The largest off-origin peak in the Patterson function is 5.14% of the height of the origin peak. No significant pseudotranslation is detected.*

¹Intensities estimated from amplitudes.

²Theoretical values of $\langle |L| \rangle$, $\langle L^2 \rangle$ for acentric reflections are 0.5, 0.333 respectively for untwinned datasets, and 0.375, 0.2 for perfectly twinned datasets.

5 Model quality [i](#)

5.1 Standard geometry [i](#)

Bond lengths and bond angles in the following residue types are not validated in this section:
HDD

The Z score for a bond length (or angle) is the number of standard deviations the observed value is removed from the expected value. A bond length (or angle) with $|Z| > 5$ is considered an outlier worth inspection. RMSZ is the root-mean-square of all Z scores of the bond lengths (or angles).

Mol	Chain	Bond lengths		Bond angles	
		RMSZ	# Z >5	RMSZ	# Z >5
1	A	0.73	0/1851	0.96	13/2513 (0.5%)
1	B	0.72	0/1862	0.98	15/2527 (0.6%)
1	C	0.74	0/1860	0.94	9/2525 (0.4%)
1	D	0.71	0/1862	0.93	7/2527 (0.3%)
1	I	0.77	1/1851 (0.1%)	0.96	12/2513 (0.5%)
1	J	0.71	0/1851	0.95	7/2513 (0.3%)
1	K	0.81	0/1851	0.97	10/2513 (0.4%)
1	L	0.69	0/1862	0.93	9/2527 (0.4%)
2	E	0.69	0/2188	0.85	8/2975 (0.3%)
2	F	0.72	0/2159	0.88	4/2936 (0.1%)
2	G	0.72	0/2181	0.88	11/2965 (0.4%)
2	H	0.72	0/2170	0.89	11/2951 (0.4%)
2	M	0.74	0/2168	0.89	10/2947 (0.3%)
2	N	0.70	0/2170	0.87	11/2951 (0.4%)
2	O	0.77	0/2159	0.90	7/2936 (0.2%)
2	P	0.72	0/2159	0.89	11/2936 (0.4%)
All	All	0.73	1/32204 (0.0%)	0.91	155/43755 (0.4%)

All (1) bond length outliers are listed below:

Mol	Chain	Res	Type	Atoms	Z	Observed(Å)	Ideal(Å)
1	I	120	GLU	CD-OE1	5.56	1.31	1.25

All (155) bond angle outliers are listed below:

Mol	Chain	Res	Type	Atoms	Z	Observed(°)	Ideal(°)
1	I	111	ARG	NE-CZ-NH2	9.40	125.00	120.30
1	A	155	ASP	CB-CG-OD2	9.37	126.73	118.30
1	J	91	ASP	CB-CG-OD2	8.90	126.31	118.30
2	M	405	ASP	CB-CG-OD2	8.66	126.10	118.30

Continued on next page...

Continued from previous page...

Mol	Chain	Res	Type	Atoms	Z	Observed(°)	Ideal(°)
1	C	267	ARG	NE-CZ-NH1	8.37	124.48	120.30
1	D	91	ASP	CB-CG-OD2	8.35	125.82	118.30
1	L	155	ASP	CB-CG-OD2	8.13	125.62	118.30
2	O	446	ASP	CB-CG-OD2	7.89	125.40	118.30
1	B	155	ASP	CB-CG-OD2	7.80	125.32	118.30
1	B	216	ASP	CB-CG-OD2	7.64	125.18	118.30
1	J	241	ASP	CB-CG-OD2	7.64	125.18	118.30
2	N	467	ASP	CB-CG-OD2	7.54	125.08	118.30
1	L	91	ASP	CB-CG-OD2	7.49	125.05	118.30
1	J	216	ASP	CB-CG-OD2	7.41	124.97	118.30
1	C	90	ASP	CB-CG-OD2	7.34	124.91	118.30
2	H	525	ASP	CB-CG-OD2	7.30	124.87	118.30
2	O	355	ASP	CB-CG-OD2	7.25	124.83	118.30
1	B	151	ASP	CB-CG-OD2	7.25	124.82	118.30
1	L	197	ASP	CB-CG-OD2	7.22	124.80	118.30
1	D	241	ASP	CB-CG-OD2	7.17	124.76	118.30
2	N	401	ASP	CB-CG-OD2	7.16	124.75	118.30
1	I	216	ASP	CB-CG-OD2	7.13	124.72	118.30
2	O	467	ASP	CB-CG-OD2	7.09	124.68	118.30
1	K	197	ASP	CB-CG-OD2	7.08	124.67	118.30
1	L	177	ASP	CB-CG-OD2	7.07	124.67	118.30
1	C	197	ASP	CB-CG-OD2	7.06	124.65	118.30
2	G	405	ASP	CB-CG-OD2	7.04	124.64	118.30
1	A	267	ARG	NE-CZ-NH1	7.04	123.82	120.30
2	F	446	ASP	CB-CG-OD2	6.99	124.59	118.30
1	B	146	ASP	CB-CG-OD2	6.96	124.56	118.30
2	P	446	ASP	CB-CG-OD2	6.92	124.53	118.30
2	G	355	ASP	CB-CG-OD2	6.91	124.52	118.30
2	O	405	ASP	CB-CG-OD2	6.90	124.51	118.30
1	A	90	ASP	CB-CG-OD2	6.86	124.48	118.30
1	A	267	ARG	NE-CZ-NH2	-6.79	116.90	120.30
1	I	91	ASP	CB-CG-OD2	6.78	124.40	118.30
1	B	259	ASP	CB-CG-OD2	6.78	124.40	118.30
2	M	545	ASP	CB-CG-OD2	6.77	124.39	118.30
1	K	177	ASP	CB-CG-OD2	6.76	124.39	118.30
1	I	111	ARG	NE-CZ-NH1	-6.74	116.93	120.30
1	C	118	ASP	CB-CG-OD2	6.70	124.33	118.30
1	D	216	ASP	CB-CG-OD2	6.69	124.32	118.30
1	A	259	ASP	CB-CG-OD2	6.65	124.29	118.30
1	D	237	ASP	CB-CG-OD2	6.64	124.27	118.30
1	J	90	ASP	CB-CG-OD2	6.63	124.27	118.30
1	A	118	ASP	CB-CG-OD2	6.62	124.26	118.30

Continued on next page...

Continued from previous page...

Mol	Chain	Res	Type	Atoms	Z	Observed(°)	Ideal(°)
1	L	259	ASP	CB-CG-OD2	6.60	124.24	118.30
1	A	111	ARG	NE-CZ-NH2	6.59	123.60	120.30
1	A	177	ASP	CB-CG-OD2	6.55	124.20	118.30
1	I	90	ASP	CB-CG-OD2	6.54	124.19	118.30
2	F	330	ASP	CB-CG-OD2	6.50	124.15	118.30
1	A	91	ASP	CB-CG-OD2	6.50	124.15	118.30
1	C	155	ASP	CB-CG-OD2	6.48	124.14	118.30
1	L	90	ASP	CB-CG-OD2	6.47	124.12	118.30
2	H	545	ASP	CB-CG-OD2	6.45	124.11	118.30
2	E	525	ASP	CB-CG-OD2	6.45	124.11	118.30
2	P	401	ASP	CB-CG-OD2	6.43	124.09	118.30
2	M	330	ASP	CB-CG-OD2	6.42	124.08	118.30
1	C	241	ASP	CB-CG-OD2	6.40	124.06	118.30
2	H	314	ASP	CB-CG-OD2	6.39	124.05	118.30
1	K	241	ASP	CB-CG-OD2	6.39	124.05	118.30
1	K	155	ASP	CB-CG-OD2	6.37	124.03	118.30
2	N	330	ASP	CB-CG-OD2	6.36	124.03	118.30
2	H	446	ASP	CB-CG-OD2	6.34	124.00	118.30
2	G	330	ASP	CB-CG-OD2	6.32	123.99	118.30
2	P	380	ASP	CB-CG-OD2	6.32	123.98	118.30
2	F	355	ASP	CB-CG-OD2	6.31	123.98	118.30
1	D	197	ASP	CB-CG-OD2	6.26	123.94	118.30
2	H	405	ASP	CB-CG-OD2	6.26	123.93	118.30
1	B	210	ASP	CB-CG-OD2	6.25	123.92	118.30
1	J	146	ASP	CB-CG-OD2	6.24	123.92	118.30
2	P	330	ASP	CB-CG-OD2	6.20	123.88	118.30
2	G	377	ARG	NE-CZ-NH2	-6.20	117.20	120.30
1	A	237	ASP	CB-CG-OD2	6.18	123.86	118.30
1	I	155	ASP	CB-CG-OD2	6.17	123.85	118.30
1	B	197	ASP	CB-CG-OD2	6.10	123.79	118.30
1	J	155	ASP	CB-CG-OD2	6.09	123.79	118.30
2	H	551	ASP	CB-CG-OD2	6.09	123.78	118.30
1	K	216	ASP	CB-CG-OD2	6.08	123.78	118.30
1	J	259	ASP	CB-CG-OD2	6.07	123.76	118.30
2	E	314	ASP	CB-CG-OD2	6.03	123.73	118.30
2	E	545	ASP	CB-CG-OD2	6.01	123.71	118.30
1	K	107	ASP	CB-CG-OD2	6.01	123.71	118.30
2	F	525	ASP	CB-CG-OD2	6.00	123.70	118.30
2	N	355	ASP	CB-CG-OD2	5.94	123.65	118.30
2	O	551	ASP	CB-CG-OD2	5.94	123.64	118.30
2	N	545	ASP	CB-CG-OD2	5.93	123.64	118.30
1	A	241	ASP	CB-CG-OD2	5.93	123.64	118.30

Continued on next page...

Continued from previous page...

Mol	Chain	Res	Type	Atoms	Z	Observed(°)	Ideal(°)
1	B	183	ARG	NE-CZ-NH2	-5.91	117.35	120.30
2	P	310	LEU	CA-CB-CG	5.89	128.84	115.30
2	O	350	ASP	CB-CG-OD2	5.88	123.59	118.30
1	C	267	ARG	NE-CZ-NH2	-5.85	117.37	120.30
1	D	155	ASP	CB-CG-OD2	5.85	123.57	118.30
2	M	350	ASP	CB-CG-OD2	5.79	123.51	118.30
1	K	146	ASP	CB-CG-OD2	5.76	123.49	118.30
1	D	177	ASP	CB-CG-OD2	5.76	123.48	118.30
2	P	551	ASP	CB-CG-OD2	5.75	123.48	118.30
2	N	316	ASP	CB-CG-OD2	5.73	123.46	118.30
1	I	210	ASP	CB-CG-OD2	5.72	123.45	118.30
1	L	216	ASP	CB-CG-OD2	5.71	123.44	118.30
2	N	310	LEU	CA-CB-CG	5.69	128.39	115.30
2	N	405	ASP	CB-CG-OD2	5.69	123.42	118.30
2	G	350	ASP	CB-CG-OD2	5.69	123.42	118.30
2	N	525	ASP	CB-CG-OD2	5.68	123.42	118.30
2	N	350	ASP	CB-CG-OD2	5.67	123.40	118.30
1	B	91	ASP	CB-CG-OD2	5.67	123.40	118.30
1	B	107	ASP	CB-CG-OD2	5.66	123.40	118.30
1	L	241	ASP	CB-CG-OD2	5.66	123.39	118.30
2	H	355	ASP	CB-CG-OD2	5.64	123.38	118.30
1	B	90	ASP	CB-CG-OD2	5.64	123.37	118.30
2	H	310	LEU	CA-CB-CG	5.61	128.19	115.30
1	C	181	ASP	CB-CG-OD2	5.60	123.34	118.30
2	H	401	ASP	CB-CG-OD2	5.60	123.34	118.30
1	I	151	ASP	CB-CG-OD2	5.58	123.32	118.30
1	B	177	ASP	CB-CG-OD2	5.55	123.29	118.30
1	B	118	ASP	CB-CG-OD2	5.54	123.29	118.30
1	I	146	ASP	CB-CG-OD2	5.54	123.28	118.30
1	L	146	ASP	CB-CG-OD2	5.52	123.27	118.30
2	G	316	ASP	CB-CG-OD2	5.50	123.25	118.30
1	C	91	ASP	CB-CG-OD2	5.47	123.23	118.30
2	E	355	ASP	CB-CG-OD2	5.46	123.21	118.30
1	B	181	ASP	CB-CG-OD2	5.44	123.20	118.30
2	M	316	ASP	CB-CG-OD2	5.44	123.20	118.30
2	M	355	ASP	CB-CG-OD2	5.43	123.19	118.30
2	G	417	ASP	CB-CG-OD2	5.43	123.19	118.30
1	B	241	ASP	CB-CG-OD2	5.42	123.18	118.30
2	P	345	ASP	CB-CG-OD2	5.41	123.17	118.30
2	E	405	ASP	CB-CG-OD2	5.41	123.17	118.30
2	M	467	ASP	CB-CG-OD2	5.38	123.15	118.30
1	A	216	ASP	CB-CG-OD2	5.38	123.14	118.30

Continued on next page...

Continued from previous page...

Mol	Chain	Res	Type	Atoms	Z	Observed(°)	Ideal(°)
2	G	345	ASP	CB-CG-OD2	5.37	123.13	118.30
2	G	445	ARG	NE-CZ-NH2	5.36	122.98	120.30
2	E	350	ASP	CB-CG-OD2	5.34	123.11	118.30
1	K	183	ARG	NE-CZ-NH2	-5.34	117.63	120.30
2	M	345	ASP	CB-CG-OD2	5.32	123.09	118.30
2	P	518	PHE	CB-CA-C	5.32	121.04	110.40
2	E	467	ASP	CB-CG-OD2	5.32	123.08	118.30
2	M	314	ASP	CB-CG-OD2	5.32	123.08	118.30
2	O	316	ASP	CB-CG-OD2	5.31	123.08	118.30
2	E	310	LEU	CA-CB-CG	5.31	127.51	115.30
2	G	545	ASP	CB-CG-OD2	5.30	123.07	118.30
2	P	355	ASP	CB-CG-OD2	5.29	123.06	118.30
1	I	177	ASP	CB-CG-OD2	5.29	123.06	118.30
1	I	237	ASP	CB-CG-OD2	5.25	123.02	118.30
1	A	151	ASP	CB-CG-OD2	5.23	123.01	118.30
1	K	181	ASP	CB-CG-OD2	5.21	122.99	118.30
2	H	467	ASP	CB-CG-OD2	5.19	122.97	118.30
2	G	446	ASP	CB-CG-OD2	5.17	122.96	118.30
1	I	107	ASP	CB-CG-OD2	5.13	122.92	118.30
2	N	536	ARG	NE-CZ-NH2	-5.11	117.74	120.30
2	P	545	ASP	CB-CG-OD2	5.08	122.88	118.30
2	H	352	ASP	CB-CG-OD2	5.08	122.87	118.30
2	M	446	ASP	CB-CG-OD2	5.07	122.86	118.30
2	P	316	ASP	CB-CG-OD2	5.03	122.83	118.30
1	K	197	ASP	CB-CG-OD1	-5.01	113.80	118.30

There are no chirality outliers.

There are no planarity outliers.

5.2 Too-close contacts

In the following table, the Non-H and H(model) columns list the number of non-hydrogen atoms and hydrogen atoms in the chain respectively. The H(added) column lists the number of hydrogen atoms added and optimized by MolProbity. The Clashes column lists the number of clashes within the asymmetric unit, whereas Symm-Clashes lists symmetry-related clashes.

Mol	Chain	Non-H	H(model)	H(added)	Clashes	Symm-Clashes
1	A	1796	0	1720	76	0
1	B	1803	0	1729	100	0
1	C	1800	0	1729	64	0
1	D	1802	0	1729	94	1

Continued on next page...

Continued from previous page...

Mol	Chain	Non-H	H(model)	H(added)	Clashes	Symm-Clashes
1	I	1796	0	1720	99	0
1	J	1796	0	1720	77	0
1	K	1796	0	1720	110	0
1	L	1801	0	1725	79	0
2	E	2107	0	1980	81	0
2	F	2094	0	1975	105	0
2	G	2106	0	1987	88	0
2	H	2100	0	1978	85	0
2	M	2098	0	1984	122	0
2	N	2100	0	1978	93	0
2	O	2094	0	1975	133	3
2	P	2094	0	1975	116	2
3	E	44	0	28	14	0
3	F	44	0	28	25	0
3	G	44	0	28	9	0
3	H	44	0	28	15	0
3	M	44	0	28	20	0
3	N	44	0	28	12	0
3	O	44	0	28	19	0
3	P	44	0	28	11	0
4	A	21	0	0	2	0
4	B	8	0	0	3	0
4	C	20	0	0	5	0
4	D	11	0	0	5	0
4	E	20	0	0	6	0
4	F	11	0	0	9	0
4	G	11	0	0	1	0
4	H	11	0	0	2	0
4	I	5	0	0	4	0
4	J	12	0	0	4	0
4	K	3	0	0	1	0
4	L	16	0	0	4	0
4	M	2	0	0	2	0
4	N	12	0	0	3	0
4	O	4	0	0	2	0
4	P	13	0	0	4	0
All	All	31715	0	29848	1281	3

The all-atom clashscore is defined as the number of clashes found per 1000 atoms (including hydrogen atoms). The all-atom clashscore for this structure is 21.

All (1281) close contacts within the same asymmetric unit are listed below, sorted by their clash magnitude.

Atom-1	Atom-2	Interatomic distance (Å)	Clash overlap (Å)
1:L:267:ARG:HH11	1:L:267:ARG:CB	1.11	1.61
2:O:392:HIS:ND1	2:O:415:TYR:CB	1.71	1.53
2:P:392:HIS:ND1	2:P:415:TYR:CB	1.72	1.50
2:G:392:HIS:ND1	2:G:415:TYR:CB	1.74	1.48
2:N:392:HIS:ND1	2:N:415:TYR:CB	1.74	1.48
1:L:267:ARG:NH1	1:L:267:ARG:HB3	1.31	1.38
2:F:392:HIS:ND1	2:F:415:TYR:CB	1.88	1.35
1:L:267:ARG:CB	1:L:267:ARG:NH1	1.90	1.25
2:P:392:HIS:CE1	2:P:415:TYR:HB2	1.70	1.25
2:F:392:HIS:ND1	2:F:415:TYR:HB2	0.91	1.22
1:I:83:ASN:HB3	2:O:429:HIS:CD2	1.76	1.20
1:B:165:ARG:HD3	3:F:760:HDD:O1A	1.38	1.18
2:G:369:ARG:HG3	4:G:767:HOH:O	1.42	1.18
2:P:392:HIS:ND1	2:P:415:TYR:HB2	0.86	1.17
2:N:392:HIS:ND1	2:N:415:TYR:HB2	0.84	1.15
2:N:392:HIS:CE1	2:N:415:TYR:HB2	1.82	1.15
2:O:392:HIS:ND1	2:O:415:TYR:HB2	0.80	1.13
2:N:412:LEU:O	1:L:111:ARG:NH2	1.82	1.11
2:G:392:HIS:ND1	2:G:415:TYR:HB2	0.79	1.11
2:G:392:HIS:CE1	2:G:415:TYR:HB2	1.84	1.10
2:O:392:HIS:CG	2:O:415:TYR:HB2	1.87	1.07
1:B:267[B]:ARG:HH22	2:F:330:ASP:HB2	1.13	1.07
1:B:267[B]:ARG:NH2	2:F:330:ASP:HB2	1.69	1.06
1:K:201:ASN:CG	3:O:760:HDD:HMB2	1.74	1.06
2:M:309:LYS:CB	2:M:311:THR:HG23	1.84	1.06
2:G:449[B]:HIS:HE1	2:G:451:MET:SD	1.79	1.05
2:O:392:HIS:CE1	2:O:415:TYR:HB2	1.90	1.05
2:G:309:LYS:CB	2:G:311:THR:HG23	1.86	1.05
2:F:509:ARG:HG3	2:F:509:ARG:HH11	1.22	1.03
3:P:760:HDD:HBB1	3:P:760:HDD:CMB	1.87	1.03
1:D:267[B]:ARG:HG3	1:D:267[B]:ARG:NH1	1.64	1.02
2:O:355:ASP:OD1	2:O:358:LYS:HE2	1.58	1.02
1:B:76:GLU:OE1	1:B:76:GLU:O	1.77	1.01
1:D:267[B]:ARG:HG3	1:D:267[B]:ARG:HH11	0.83	1.00
1:B:77:ASN:H	1:B:77:ASN:HD22	1.03	1.00
2:G:392:HIS:CG	2:G:415:TYR:HB2	1.97	0.99
3:P:760:HDD:HBB1	3:P:760:HDD:HMB1	1.01	0.99
1:D:267[B]:ARG:HH11	1:D:267[B]:ARG:CG	1.76	0.99
2:F:392:HIS:CG	2:F:415:TYR:HB2	1.99	0.98
2:E:419:GLN:NE2	2:E:419:GLN:HA	1.76	0.98
2:M:438:CYS:HB2	2:M:439:PRO:HD2	1.46	0.98
2:G:449[B]:HIS:CE1	2:G:451:MET:SD	2.58	0.96

Continued on next page...

Continued from previous page...

Atom-1	Atom-2	Interatomic distance (Å)	Clash overlap (Å)
2:O:366:PRO:HA	4:O:763:HOH:O	1.63	0.96
2:N:419:GLN:NE2	2:N:419:GLN:HA	1.80	0.96
2:M:416:THR:HG22	2:M:417:ASP:N	1.81	0.95
2:N:309:LYS:CB	2:N:311:THR:HG23	1.96	0.95
2:F:309:LYS:CB	2:F:311:THR:HG23	1.96	0.95
1:L:77:ASN:HD22	1:L:77:ASN:N	1.63	0.94
1:I:267:ARG:HH21	2:M:330:ASP:HB2	1.30	0.94
2:P:392:HIS:CD2	2:P:394:GLY:H	1.84	0.94
2:G:369:ARG:HG2	2:G:369:ARG:HH11	1.31	0.93
1:K:293:TRP:CZ3	2:O:336:LEU:HB2	2.02	0.93
2:O:411:ARG:HG2	2:O:415:TYR:HE2	1.31	0.93
2:F:488:ARG:CD	4:F:761:HOH:O	2.15	0.93
2:P:459:ASN:HD22	2:P:459:ASN:H	1.01	0.93
1:C:267:ARG:CB	1:C:267:ARG:HH11	1.82	0.92
2:N:392:HIS:CG	2:N:415:TYR:HB2	2.03	0.92
2:F:392:HIS:CE1	2:F:415:TYR:HB2	2.03	0.92
2:G:419:GLN:HA	2:G:419:GLN:NE2	1.82	0.92
2:M:416:THR:HG22	2:M:417:ASP:H	1.32	0.92
3:P:760:HDD:HMB1	3:P:760:HDD:CBB	1.94	0.91
1:L:267:ARG:NH1	1:L:267:ARG:HB2	1.81	0.91
1:K:294:LYS:HD3	1:K:295:PRO:HD2	1.53	0.90
2:E:309:LYS:CB	2:E:311:THR:HG23	2.01	0.90
1:K:276:THR:O	2:O:403:THR:CG2	2.20	0.90
2:F:414:SER:CB	3:F:760:HDD:HBC1	2.01	0.89
1:J:77:ASN:N	1:J:77:ASN:HD22	1.68	0.89
2:F:459:ASN:HD22	2:F:459:ASN:H	1.15	0.89
1:I:125:ARG:HB3	3:M:760:HDD:HBD1	1.54	0.89
2:P:459:ASN:HD22	2:P:459:ASN:N	1.70	0.88
1:I:127:VAL:HA	4:I:304:HOH:O	1.70	0.88
2:O:419:GLN:HA	2:O:419:GLN:NE2	1.87	0.88
2:M:429:HIS:CD2	1:K:83:ASN:HB3	2.09	0.88
1:A:267:ARG:HH11	1:A:267:ARG:HG2	1.38	0.88
1:A:127:VAL:HG22	3:E:760:HDD:HMD2	1.56	0.87
2:G:493:LYS:HE3	2:H:487:GLU:OE2	1.71	0.87
1:K:201:ASN:OD1	3:O:760:HDD:HMB2	1.71	0.87
2:P:458:ALA:HA	4:P:761:HOH:O	1.73	0.87
3:E:760:HDD:HMB1	3:E:760:HDD:HBB1	1.54	0.86
2:M:487:GLU:OE2	2:N:493:LYS:HE3	1.75	0.86
1:K:249:THR:O	1:K:253:VAL:HG23	1.76	0.86
1:B:125:ARG:HB3	3:F:760:HDD:HBD1	1.54	0.86
1:B:267[B]:ARG:HD3	1:B:297:ALA:HB2	1.58	0.86

Continued on next page...

Continued from previous page...

Atom-1	Atom-2	Interatomic distance (Å)	Clash overlap (Å)
1:A:274:ILE:HD12	3:E:760:HDD:HBB1	1.59	0.85
1:I:77:ASN:HB3	2:O:469:TRP:CZ3	2.11	0.85
2:M:456:ASN:ND2	2:M:458:ALA:H	1.73	0.85
2:M:351:PHE:HB2	2:M:358[B]:LYS:CD	2.07	0.85
2:H:309:LYS:CB	2:H:311:THR:HG23	2.06	0.85
1:J:278:ARG:NH2	2:N:487:GLU:OE1	2.09	0.84
2:E:419:GLN:HA	2:E:419:GLN:HE21	1.43	0.84
2:P:392:HIS:CG	2:P:415:TYR:HB2	2.06	0.84
1:B:201:ASN:CG	3:F:760:HDD:HMB2	1.97	0.83
2:H:467:ASP:O	2:H:471:ARG:NH1	2.11	0.82
2:P:419:GLN:HA	2:P:419:GLN:NE2	1.93	0.82
1:K:276:THR:O	2:O:403:THR:HG21	1.77	0.82
1:B:267[B]:ARG:HD3	1:B:297:ALA:CB	2.09	0.82
2:N:467:ASP:O	2:N:471:ARG:NH1	2.13	0.82
2:N:509:ARG:HH11	2:N:509:ARG:HB2	1.43	0.82
1:K:183:ARG:O	1:K:201:ASN:HB3	1.80	0.81
1:J:77:ASN:HD22	1:J:77:ASN:H	1.24	0.81
2:M:407:LEU:HD23	3:M:760:HDD:HBB2	1.62	0.81
2:M:416:THR:CG2	2:M:417:ASP:N	2.44	0.81
2:E:419:GLN:HE22	2:E:422:ARG:HH11	1.28	0.81
1:C:214:PHE:HB3	1:C:215:PRO:HD3	1.63	0.81
2:O:309:LYS:CB	2:O:311:THR:HG23	2.12	0.80
2:P:392:HIS:ND1	2:P:415:TYR:HB3	1.96	0.80
1:A:212:HIS:O	1:D:113:LYS:HE2	1.82	0.80
1:L:183[B]:ARG:NH1	2:P:318:HIS:ND1	2.30	0.80
1:B:201:ASN:OD1	3:F:760:HDD:HMB2	1.82	0.80
2:M:351:PHE:HB2	2:M:358[B]:LYS:HD3	1.64	0.80
2:M:419:GLN:HE22	2:M:422:ARG:NH1	1.80	0.80
1:K:165:ARG:HH11	3:O:760:HDD:CGA	1.93	0.79
1:B:77:ASN:H	1:B:77:ASN:ND2	1.78	0.79
2:H:456:ASN:OD1	2:H:458:ALA:N	2.13	0.79
1:C:125:ARG:HB3	3:G:760:HDD:HBD1	1.64	0.79
2:E:467:ASP:O	2:E:471:ARG:NH1	2.16	0.79
1:I:201:ASN:CG	3:M:760:HDD:HMB2	2.03	0.79
2:N:448:MET:HG3	2:N:449[B]:HIS:CD2	2.18	0.79
2:P:309:LYS:CB	2:P:311:THR:HG23	2.12	0.79
2:F:354:LEU:HA	4:F:767:HOH:O	1.83	0.78
1:I:125:ARG:HB3	3:M:760:HDD:CBD	2.13	0.78
2:E:369:ARG:HG2	2:E:369:ARG:HH11	1.47	0.78
2:N:355:ASP:OD1	2:N:358:LYS:HE2	1.84	0.78
2:M:467:ASP:O	2:M:471:ARG:NH1	2.16	0.78

Continued on next page...

Continued from previous page...

Atom-1	Atom-2	Interatomic distance (Å)	Clash overlap (Å)
2:M:412:LEU:O	1:K:111:ARG:NH2	2.17	0.78
1:B:76:GLU:O	1:B:76:GLU:CG	2.30	0.78
2:F:449:HIS:CD2	2:H:449[A]:HIS:HD2	2.00	0.78
2:P:416:THR:HG22	2:P:417:ASP:N	1.97	0.78
1:C:76:GLU:HG3	1:C:78:TYR:CE2	2.19	0.77
1:I:83:ASN:HB3	2:O:429:HIS:HD2	1.44	0.77
2:M:456:ASN:HD22	2:M:457:PRO:N	1.81	0.77
4:B:305:HOH:O	2:F:422:ARG:HD2	1.84	0.77
1:K:201:ASN:ND2	3:O:760:HDD:HMB2	1.99	0.77
1:B:77:ASN:HD22	1:B:77:ASN:N	1.75	0.77
2:E:412:LEU:O	1:C:111:ARG:NH2	2.18	0.77
2:F:488:ARG:HD3	4:F:761:HOH:O	1.81	0.77
2:M:438:CYS:HB2	2:M:439:PRO:CD	2.14	0.77
1:I:267:ARG:NH2	2:M:330:ASP:HB2	2.00	0.77
1:K:101:GLY:O	4:K:302:HOH:O	2.04	0.76
1:B:76:GLU:O	1:B:76:GLU:CD	2.24	0.76
2:M:392:HIS:O	2:M:395:HIS:HB2	1.84	0.76
2:P:327:GLU:OE1	4:P:767:HOH:O	2.03	0.76
1:D:201:ASN:CG	3:H:760:HDD:HMB2	2.07	0.75
2:H:419:GLN:HA	2:H:419:GLN:NE2	1.99	0.75
3:N:760:HDD:HBC1	3:N:760:HDD:HMC1	1.68	0.75
2:O:382:PHE:CZ	2:O:386:ASN:ND2	2.53	0.75
1:D:206:PHE:CG	3:H:760:HDD:CBB	2.68	0.75
1:A:201:ASN:CG	3:E:760:HDD:HMB2	2.08	0.75
1:C:207:PHE:CD1	1:C:217:PHE:CZ	2.75	0.74
2:M:419:GLN:HE22	2:M:422:ARG:HH11	1.34	0.74
2:M:456:ASN:HD22	2:M:456:ASN:C	1.89	0.74
1:B:206:PHE:HB2	3:F:760:HDD:HBB2	1.69	0.74
1:D:282:ALA:N	4:D:310:HOH:O	2.07	0.74
1:C:267:ARG:HH11	1:C:267:ARG:HB3	1.53	0.74
1:J:231:GLN:O	1:J:233:GLN:HG3	1.88	0.74
2:O:411:ARG:HG2	2:O:415:TYR:CE2	2.21	0.74
2:M:309:LYS:CB	2:M:311:THR:CG2	2.65	0.73
2:N:419:GLN:HA	2:N:419:GLN:HE21	1.52	0.72
1:K:294:LYS:HD3	1:K:295:PRO:CD	2.17	0.72
2:O:392:HIS:ND1	2:O:415:TYR:CA	2.52	0.72
1:C:274:ILE:HD12	3:G:760:HDD:HMB1	1.71	0.72
1:D:266:TYR:HB2	1:D:267[B]:ARG:HH12	1.54	0.72
1:J:201:ASN:CG	3:N:760:HDD:HMB2	2.10	0.72
2:P:563:GLY:O	2:P:564:ILE:HG13	1.89	0.72
2:F:414:SER:CB	3:F:760:HDD:CBC	2.67	0.72

Continued on next page...

Continued from previous page...

Atom-1	Atom-2	Interatomic distance (Å)	Clash overlap (Å)
1:D:214:PHE:HB3	1:D:215:PRO:HD3	1.71	0.72
2:H:407:LEU:HD21	3:H:760:HDD:HBB2	1.70	0.72
1:J:125:ARG:HB3	3:N:760:HDD:HBD1	1.72	0.71
1:K:125:ARG:HB3	3:O:760:HDD:HBD1	1.72	0.71
2:G:493:LYS:CE	2:H:487:GLU:OE2	2.37	0.71
1:L:77:ASN:HD22	1:L:77:ASN:H	1.39	0.71
1:B:293:TRP:CZ3	2:F:336:LEU:HB2	2.24	0.71
1:K:131:GLY:O	2:O:319:ARG:NH2	2.23	0.71
2:O:414:SER:HB3	3:O:760:HDD:HBC1	1.73	0.71
1:A:251:HIS:CE1	2:E:359:LEU:HD23	2.26	0.71
1:B:111:ARG:NH2	2:H:412:LEU:O	2.23	0.71
2:G:416:THR:HG22	2:G:417:ASP:N	2.06	0.71
1:J:206:PHE:HB2	3:N:760:HDD:HBB2	1.73	0.71
2:O:457:PRO:O	2:O:465:ILE:HD11	1.91	0.71
1:L:183[B]:ARG:NH1	2:P:318:HIS:CE1	2.59	0.71
3:M:760:HDD:HMC1	3:M:760:HDD:HBC1	1.71	0.71
1:I:119:HIS:HB2	2:O:426:PRO:HG3	1.72	0.70
1:L:183[B]:ARG:HH11	2:P:318:HIS:CE1	2.09	0.70
2:F:449:HIS:CD2	2:H:449[A]:HIS:CD2	2.79	0.70
2:F:512:TRP:CZ3	2:F:554:LEU:HD13	2.26	0.70
2:P:392:HIS:CD2	2:P:394:GLY:N	2.59	0.70
4:B:306:HOH:O	2:F:422:ARG:HD3	1.91	0.70
2:F:381:ASN:ND2	4:F:763:HOH:O	2.24	0.70
2:O:323:TRP:CZ3	2:O:378:ASN:HB3	2.27	0.70
1:L:77:ASN:N	1:L:77:ASN:ND2	2.38	0.70
1:D:142:LYS:HA	1:D:156:PRO:HG3	1.74	0.70
2:F:412:LEU:O	1:D:111:ARG:NH2	2.25	0.70
1:C:267:ARG:HH11	1:C:267:ARG:HB2	1.57	0.70
2:G:537:PRO:O	2:G:540:ARG:HB2	1.92	0.70
1:K:273:GLY:O	1:K:275:HIS:N	2.25	0.70
2:G:419:GLN:HA	2:G:419:GLN:HE21	1.55	0.69
2:P:392:HIS:CG	2:P:415:TYR:CB	2.72	0.69
1:D:201:ASN:ND2	3:H:760:HDD:HMB2	2.07	0.69
2:N:449[B]:HIS:HD1	2:P:449:HIS:CG	2.11	0.69
2:G:467:ASP:O	2:G:471:ARG:NH1	2.24	0.69
1:I:77:ASN:HB3	2:O:469:TRP:CE3	2.27	0.69
2:E:419:GLN:NE2	2:E:419:GLN:CA	2.55	0.69
2:E:396:ILE:HD13	2:E:402:PHE:CE2	2.28	0.69
2:O:355:ASP:OD1	2:O:358:LYS:CE	2.40	0.69
1:L:201:ASN:ND2	3:P:760:HDD:HMB2	2.08	0.69
1:K:276:THR:O	2:O:403:THR:HG23	1.90	0.69

Continued on next page...

Continued from previous page...

Atom-1	Atom-2	Interatomic distance (Å)	Clash overlap (Å)
1:B:206:PHE:CG	3:F:760:HDD:CBB	2.76	0.68
2:O:416:THR:HG22	2:O:417:ASP:N	2.08	0.68
2:G:419:GLN:HE22	2:G:422:ARG:NH1	1.91	0.68
2:M:448:MET:HE2	1:K:122:ILE:HG22	1.75	0.68
2:O:392:HIS:HB2	2:O:415:TYR:HB3	1.75	0.68
2:P:467:ASP:O	2:P:471:ARG:NH1	2.26	0.68
2:G:438:CYS:HB2	2:G:439:PRO:HD2	1.76	0.68
2:F:509:ARG:HH11	2:F:509:ARG:CG	2.04	0.68
2:G:419:GLN:NE2	2:G:419:GLN:CA	2.53	0.68
2:M:461:GLU:HA	2:M:462:PRO:C	2.12	0.68
1:J:201:ASN:ND2	3:N:760:HDD:HMB2	2.09	0.68
2:N:449[B]:HIS:ND1	2:P:449:HIS:HB2	2.09	0.68
2:G:392:HIS:ND1	2:G:415:TYR:CG	2.61	0.68
2:F:381:ASN:CG	4:F:763:HOH:O	2.32	0.68
2:M:402:PHE:HB3	2:M:408:LEU:HD21	1.76	0.68
3:E:760:HDD:HBD2	4:E:137:HOH:O	1.94	0.67
2:G:443:PHE:CZ	2:G:470:PRO:HD2	2.29	0.67
1:K:125:ARG:HB3	3:O:760:HDD:CBD	2.24	0.67
1:K:165:ARG:NH1	3:O:760:HDD:O2A	2.24	0.67
2:P:456:ASN:OD1	2:P:457:PRO:HD2	1.95	0.67
1:J:120:GLU:HG2	2:P:446:ASP:HB2	1.75	0.67
2:F:414:SER:HB3	3:F:760:HDD:HBC1	1.76	0.67
2:E:392:HIS:CD2	2:E:394:GLY:H	2.11	0.67
2:P:563:GLY:C	2:P:564:ILE:HG13	2.14	0.67
1:L:267:ARG:HH11	1:L:267:ARG:HB3	0.50	0.67
1:C:279:LEU:O	1:C:280:ILE:HD13	1.95	0.66
1:K:278:ARG:HH22	2:O:487:GLU:CD	1.99	0.66
2:G:369:ARG:HH11	2:G:369:ARG:CG	2.07	0.66
2:P:351:PHE:HB2	4:P:773:HOH:O	1.94	0.66
1:B:125:ARG:CB	3:F:760:HDD:HBD1	2.25	0.66
2:F:323:TRP:CZ3	2:F:378:ASN:HB3	2.29	0.66
2:N:449[B]:HIS:CE1	2:P:449:HIS:HB2	2.31	0.66
1:K:286:ALA:HB2	2:O:485:TYR:CE1	2.30	0.66
2:N:392:HIS:CD2	2:N:394:GLY:H	2.13	0.66
2:E:449[B]:HIS:HB2	2:G:449[B]:HIS:CD2	2.30	0.66
2:F:509:ARG:HG3	2:F:509:ARG:NH1	2.00	0.66
1:I:265:SER:OG	1:I:267:ARG:HB2	1.95	0.66
1:B:76:GLU:HG3	1:B:78:TYR:CE2	2.31	0.66
1:L:279:LEU:C	1:L:280:ILE:HD13	2.14	0.66
2:P:438:CYS:HB2	2:P:439:PRO:CD	2.26	0.66
4:A:315:HOH:O	2:E:478:LYS:HD2	1.94	0.66

Continued on next page...

Continued from previous page...

Atom-1	Atom-2	Interatomic distance (Å)	Clash overlap (Å)
2:O:414:SER:CB	3:O:760:HDD:CBC	2.74	0.66
2:O:438:CYS:HB2	2:O:439:PRO:HD2	1.78	0.66
2:P:356:PRO:HG3	2:P:407:LEU:HB2	1.76	0.66
1:A:76:GLU:HG3	1:A:78:TYR:CE2	2.30	0.65
2:M:419:GLN:HE21	2:M:419:GLN:HA	1.61	0.65
2:O:382:PHE:CE1	2:O:386:ASN:ND2	2.62	0.65
1:A:251:HIS:HE1	2:E:359:LEU:HD23	1.60	0.65
1:K:196:PHE:CE1	2:O:400:LEU:HD13	2.31	0.65
2:H:392:HIS:O	2:H:395:HIS:HB2	1.96	0.65
2:N:438:CYS:HB2	2:N:439:PRO:CD	2.26	0.65
1:I:165:ARG:HD3	3:M:760:HDD:O2A	1.97	0.65
2:M:419:GLN:HA	2:M:419:GLN:NE2	2.11	0.65
1:L:158:LYS:CE	4:L:310:HOH:O	2.43	0.65
2:E:461:GLU:O	1:B:213:LYS:NZ	2.27	0.65
1:J:76:GLU:HG3	1:J:78:TYR:CE2	2.31	0.65
1:A:95:LEU:HB3	1:A:107:ASP:HB2	1.79	0.65
2:F:414:SER:HB2	3:F:760:HDD:CBC	2.27	0.65
1:D:265:SER:HB2	1:D:267[B]:ARG:NH2	2.11	0.65
2:F:382:PHE:N	4:F:763:HOH:O	2.30	0.64
2:F:416:THR:HG22	2:F:417:ASP:N	2.12	0.64
1:B:267[B]:ARG:CD	1:B:297:ALA:CB	2.75	0.64
1:K:279:LEU:O	1:K:280:ILE:HD13	1.97	0.64
1:A:92:GLN:HA	1:D:213:LYS:HD3	1.80	0.64
1:B:76:GLU:O	1:B:76:GLU:HG3	1.97	0.64
2:G:361:PRO:HG2	2:G:364:LEU:HD12	1.77	0.64
1:I:196:PHE:CE1	2:M:400:LEU:HD13	2.32	0.64
1:I:201:ASN:OD1	3:M:760:HDD:HMB2	1.97	0.64
2:E:443:PHE:CZ	2:E:470:PRO:HD2	2.32	0.64
1:B:76:GLU:OE1	1:B:76:GLU:C	2.36	0.64
1:D:128:HIS:CE1	1:D:169:VAL:HG22	2.33	0.64
1:D:206:PHE:CG	3:H:760:HDD:HBB2	2.32	0.64
1:L:158:LYS:HE3	4:L:310:HOH:O	1.97	0.64
2:F:467:ASP:O	2:F:471:ARG:NH1	2.31	0.64
2:M:461:GLU:OE2	2:M:461:GLU:C	2.36	0.64
1:A:77:ASN:HB3	2:G:469:TRP:CZ3	2.33	0.64
1:J:213:LYS:HD3	1:K:92:GLN:HA	1.79	0.64
2:E:369:ARG:HH11	2:E:369:ARG:CG	2.11	0.64
2:F:449:HIS:HB2	2:H:449[B]:HIS:CD2	2.33	0.63
1:I:279:LEU:C	1:I:280:ILE:HD13	2.18	0.63
1:J:222:LYS:NZ	1:K:121:ARG:HH21	1.96	0.63
2:P:416:THR:CG2	2:P:417:ASP:N	2.60	0.63

Continued on next page...

Continued from previous page...

Atom-1	Atom-2	Interatomic distance (Å)	Clash overlap (Å)
1:B:142:LYS:HA	1:B:156:PRO:HG3	1.80	0.63
1:B:83:ASN:HB3	2:H:429:HIS:CD2	2.34	0.63
2:G:363:GLU:CD	2:G:363:GLU:H	1.99	0.63
2:H:323:TRP:CD2	2:H:378:ASN:ND2	2.66	0.63
2:M:459:ASN:HD22	2:M:459:ASN:H	1.44	0.63
2:M:469:TRP:CE3	1:K:77:ASN:HB3	2.32	0.63
1:K:164:VAL:CG2	1:K:187:THR:HG23	2.29	0.63
2:O:461:GLU:HA	2:O:462:PRO:C	2.19	0.63
2:E:483[B]:GLU:OE1	2:E:486[B]:GLN:OE1	2.17	0.63
2:O:509:ARG:HG2	2:O:550:ILE:O	1.99	0.63
2:M:456:ASN:HD22	2:M:458:ALA:H	1.46	0.63
2:F:429:HIS:CD2	1:D:83:ASN:HB3	2.34	0.63
2:G:509[A]:ARG:HG3	2:G:550:ILE:O	1.98	0.63
1:I:293:TRP:CZ3	2:M:336:LEU:HB2	2.34	0.63
2:P:404:ASN:O	2:P:405:ASP:C	2.38	0.62
1:A:179:VAL:O	1:A:183:ARG:NH2	2.32	0.62
1:I:105:LEU:HD11	2:O:413:PHE:HB2	1.80	0.62
1:J:111:ARG:NH2	2:P:412:LEU:O	2.32	0.62
2:P:355:ASP:HB3	2:P:358:LYS:HG3	1.81	0.62
1:K:148:THR:HG23	1:K:148:THR:O	1.97	0.62
2:E:545:ASP:O	2:E:548:ALA:HB3	2.00	0.62
2:F:438:CYS:HB2	2:F:439:PRO:HD2	1.80	0.62
2:H:438:CYS:HB2	2:H:439:PRO:CD	2.28	0.62
2:H:471:ARG:HA	4:H:771:HOH:O	1.98	0.62
2:N:392:HIS:CG	2:N:415:TYR:CB	2.73	0.62
1:A:249:THR:O	1:A:253:VAL:HG23	1.99	0.62
2:O:459:ASN:H	2:O:459:ASN:HD22	1.46	0.62
1:D:265:SER:HB2	1:D:267[B]:ARG:CZ	2.30	0.62
2:M:512:TRP:CZ3	2:M:554:LEU:HD13	2.34	0.62
1:J:214:PHE:HB3	1:J:215:PRO:HD3	1.80	0.62
2:O:419:GLN:HA	2:O:419:GLN:HE21	1.64	0.62
1:L:197:ASP:HB2	2:P:392:HIS:O	1.99	0.62
2:P:416:THR:HG22	2:P:417:ASP:H	1.64	0.62
2:G:392:HIS:CD2	2:G:394:GLY:H	2.18	0.62
2:H:419:GLN:HA	2:H:419:GLN:HE21	1.65	0.62
1:I:83:ASN:CB	2:O:429:HIS:CD2	2.69	0.62
2:M:382:PHE:CE1	2:M:386:ASN:ND2	2.67	0.62
1:B:120:GLU:HG2	2:H:446:ASP:HB2	1.82	0.62
1:B:267[B]:ARG:HH11	1:B:267[B]:ARG:CG	2.12	0.62
2:N:411:ARG:HG2	2:N:415:TYR:HE2	1.65	0.62
1:K:136:GLY:HA3	2:O:374:VAL:O	1.98	0.62

Continued on next page...

Continued from previous page...

Atom-1	Atom-2	Interatomic distance (Å)	Clash overlap (Å)
1:L:214:PHE:HB3	1:L:215:PRO:HD3	1.82	0.62
2:M:505:TYR:C	2:M:508:PRO:HD2	2.20	0.62
2:E:419:GLN:HE22	2:E:422:ARG:NH1	1.97	0.61
2:M:493:LYS:HE3	2:N:487:GLU:OE2	2.00	0.61
2:N:459:ASN:HD22	2:N:459:ASN:H	1.48	0.61
2:O:392:HIS:CG	2:O:415:TYR:CB	2.62	0.61
1:B:278:ARG:NH2	2:F:487:GLU:OE1	2.34	0.61
2:F:419:GLN:NE2	2:F:419:GLN:HA	2.15	0.61
2:G:369:ARG:HG2	2:G:369:ARG:NH1	2.10	0.61
2:H:563:GLY:C	2:H:564:ILE:HG13	2.21	0.61
1:A:201:ASN:ND2	3:E:760:HDD:HMB2	2.15	0.61
1:J:123:PRO:HG3	1:K:123:PRO:HD3	1.83	0.61
1:K:231:GLN:O	1:K:233:GLN:HG3	2.00	0.61
1:A:209:GLN:N	4:A:311:HOH:O	2.34	0.61
1:I:188:LYS:HG3	1:I:197:ASP:OD2	2.00	0.61
1:K:122:ILE:HB	1:K:123:PRO:HD2	1.82	0.61
1:C:278:ARG:NH1	4:C:317:HOH:O	2.14	0.60
2:M:355:ASP:OD1	2:M:358[B]:LYS:NZ	2.33	0.60
2:M:469:TRP:CZ3	1:K:77:ASN:HB3	2.36	0.60
1:I:212:HIS:O	1:L:113:LYS:HE2	2.00	0.60
1:B:206:PHE:CG	3:F:760:HDD:HBB2	2.36	0.60
1:D:278:ARG:HH22	2:H:487:GLU:CD	2.04	0.60
1:I:273:GLY:O	1:I:275:HIS:N	2.33	0.60
2:F:449:HIS:HB3	2:H:449[A]:HIS:CD2	2.36	0.60
1:L:95:LEU:HB3	1:L:107:ASP:HB2	1.84	0.60
1:L:229:ILE:HG23	1:L:230:PRO:HA	1.83	0.60
2:F:369:ARG:HG2	2:F:369:ARG:HH11	1.67	0.60
1:C:293:TRP:CZ3	2:G:336:LEU:HB2	2.36	0.60
2:N:461:GLU:HA	2:N:462:PRO:C	2.20	0.60
2:H:530:GLU:OE2	4:H:765:HOH:O	2.17	0.60
1:I:121:ARG:HH21	1:L:222:LYS:NZ	1.99	0.60
2:M:411:ARG:HG2	2:M:415:TYR:HE2	1.66	0.60
1:J:87:ARG:N	4:J:305:HOH:O	1.99	0.60
1:I:116:HIS:CD2	2:O:426:PRO:HB2	2.37	0.60
1:A:279:LEU:O	1:A:280:ILE:HD13	2.01	0.60
1:I:273:GLY:C	4:I:303:HOH:O	2.39	0.60
2:O:323:TRP:CH2	2:O:378:ASN:HB3	2.36	0.60
1:B:77:ASN:ND2	1:B:77:ASN:N	2.40	0.59
1:C:260:ARG:HH11	1:C:260:ARG:CG	2.15	0.59
1:L:168:THR:CG2	1:L:183[B]:ARG:NH2	2.65	0.59
2:E:413:PHE:CE1	1:D:111:ARG:HG2	2.37	0.59

Continued on next page...

Continued from previous page...

Atom-1	Atom-2	Interatomic distance (Å)	Clash overlap (Å)
1:L:279:LEU:O	1:L:280:ILE:HD13	2.01	0.59
2:E:512:TRP:CZ3	2:E:554:LEU:HD13	2.37	0.59
1:D:267[A]:ARG:HH22	2:H:330:ASP:HB2	1.68	0.59
1:I:279:LEU:O	1:I:280:ILE:HD13	2.01	0.59
1:J:128:HIS:HA	1:J:168:THR:O	2.01	0.59
1:A:138:PHE:C	1:A:138:PHE:CD2	2.76	0.59
1:C:201:ASN:CG	3:G:760:HDD:HMB2	2.22	0.59
1:D:206:PHE:CD1	3:H:760:HDD:CBB	2.85	0.59
2:H:461:GLU:HA	2:H:462:PRO:C	2.23	0.59
2:N:404:ASN:O	2:N:405:ASP:C	2.40	0.59
2:N:438:CYS:HB2	2:N:439:PRO:HD2	1.85	0.59
2:O:467:ASP:O	2:O:469:TRP:CD1	2.55	0.59
1:D:267[B]:ARG:NH1	1:D:267[B]:ARG:CG	2.47	0.59
1:I:133:ALA:HA	1:I:164:VAL:O	2.02	0.59
1:I:276:THR:O	2:M:403:THR:CG2	2.51	0.59
1:D:179:VAL:O	1:D:183:ARG:NH2	2.35	0.59
1:I:251:HIS:CE1	2:M:359:LEU:HD23	2.38	0.59
1:J:207:PHE:CD1	1:J:217:PHE:CZ	2.91	0.59
2:N:433:ILE:HG13	2:N:433:ILE:O	2.02	0.59
2:O:414:SER:CB	3:O:760:HDD:HBC1	2.32	0.59
2:H:323:TRP:CG	2:H:378:ASN:ND2	2.71	0.59
1:K:164:VAL:HG22	1:K:187:THR:HG23	1.85	0.59
2:P:461:GLU:HA	2:P:462:PRO:C	2.22	0.59
2:F:449:HIS:CB	2:H:449[B]:HIS:CD2	2.86	0.58
1:D:281:ASN:HD21	1:D:285:LYS:HB3	1.67	0.58
1:D:281:ASN:ND2	1:D:285:LYS:HB3	2.18	0.58
2:P:545:ASP:O	2:P:548:ALA:HB3	2.03	0.58
1:B:206:PHE:CB	3:F:760:HDD:HBB2	2.34	0.58
2:N:538:TYR:HA	2:N:541:GLU:CG	2.34	0.58
1:K:269:MET:HG2	1:K:270:GLU:O	2.04	0.58
2:O:493:LYS:HE3	2:P:487:GLU:OE2	2.04	0.58
1:L:169:VAL:HG23	1:L:182:ILE:O	2.03	0.58
1:D:178:THR:O	2:H:311:THR:HG22	2.03	0.58
1:C:179:VAL:O	1:C:183:ARG:NH2	2.36	0.58
2:N:494:VAL:O	2:N:494:VAL:HG23	2.03	0.58
2:E:473:THR:CB	4:E:93:HOH:O	2.51	0.58
2:G:493:LYS:NZ	2:H:487:GLU:OE2	2.36	0.58
1:D:293:TRP:CZ3	2:H:336:LEU:HB2	2.38	0.58
1:J:121:ARG:HH21	1:K:222:LYS:HE3	1.68	0.58
1:D:266:TYR:H	1:D:267[B]:ARG:NH2	2.02	0.58
2:M:351:PHE:CB	2:M:358[B]:LYS:HD3	2.32	0.58

Continued on next page...

Continued from previous page...

Atom-1	Atom-2	Interatomic distance (Å)	Clash overlap (Å)
2:O:507:HIS:N	2:O:508:PRO:HD2	2.18	0.58
1:A:214:PHE:HB3	1:A:215:PRO:HD3	1.85	0.58
1:I:120:GLU:HG2	2:O:446:ASP:HB2	1.86	0.58
1:I:177:ASP:O	1:I:183:ARG:NH2	2.37	0.58
1:J:77:ASN:N	1:J:77:ASN:ND2	2.42	0.58
2:O:507:HIS:N	2:O:508:PRO:CD	2.66	0.58
1:C:260:ARG:NH1	1:C:260:ARG:HG3	2.18	0.58
1:C:290:ARG:HD2	4:C:314:HOH:O	2.02	0.58
2:G:461:GLU:O	1:D:213:LYS:NZ	2.37	0.58
1:D:164:VAL:HG22	1:D:187:THR:OG1	2.04	0.58
1:I:76:GLU:OE1	1:I:77:ASN:N	2.36	0.58
2:P:438:CYS:HB2	2:P:439:PRO:HD2	1.86	0.57
1:A:83:ASN:HB3	2:G:429:HIS:CD2	2.39	0.57
2:F:461:GLU:HA	2:F:462:PRO:C	2.24	0.57
2:G:419:GLN:HE22	2:G:422:ARG:HH11	1.52	0.57
2:F:563:GLY:C	2:F:564:ILE:HG13	2.24	0.57
1:B:292:HIS:O	2:F:336:LEU:HD12	2.04	0.57
1:C:76:GLU:HG3	1:C:78:TYR:CZ	2.38	0.57
2:P:463:ASN:ND2	2:P:468:ASN:HA	2.19	0.57
1:A:267:ARG:HG2	1:A:267:ARG:NH1	2.15	0.57
2:M:351:PHE:HB2	2:M:358[B]:LYS:HD2	1.86	0.57
1:J:142:LYS:HA	1:J:156:PRO:HG3	1.85	0.57
2:O:490:GLU:HG2	2:P:490:GLU:HG2	1.85	0.57
1:A:274:ILE:HD12	3:E:760:HDD:CBB	2.32	0.57
2:M:537:PRO:O	2:M:540:ARG:HB2	2.05	0.57
1:J:118:ASP:O	1:K:126:ILE:HD11	2.03	0.57
1:K:155:ASP:OD2	1:K:157:ASN:N	2.35	0.57
1:A:293:TRP:CZ3	2:E:336:LEU:HB2	2.39	0.57
1:C:207:PHE:CD2	1:C:252:ASN:HB3	2.40	0.57
1:I:199:VAL:HB	2:M:411:ARG:HH22	1.69	0.57
2:N:515:GLN:HB2	2:N:520:GLN:HG2	1.86	0.57
1:A:178:THR:O	2:E:311:THR:HG22	2.05	0.57
2:F:469:TRP:CZ3	1:D:77:ASN:HB3	2.40	0.57
1:B:77:ASN:HB3	2:H:469:TRP:CZ3	2.40	0.57
1:D:120:GLU:HB3	1:D:121:ARG:NH1	2.20	0.57
1:I:113:LYS:HE2	1:L:212:HIS:O	2.05	0.57
1:C:76:GLU:OE2	1:C:76:GLU:HA	2.05	0.56
1:I:95:LEU:HB3	1:I:107:ASP:HB2	1.87	0.56
2:M:461:GLU:OE2	2:M:462:PRO:N	2.38	0.56
1:B:267[B]:ARG:NH1	1:B:267[B]:ARG:HG3	2.20	0.56
2:M:448:MET:CE	1:K:122:ILE:HG22	2.34	0.56

Continued on next page...

Continued from previous page...

Atom-1	Atom-2	Interatomic distance (Å)	Clash overlap (Å)
2:E:473:THR:HB	4:E:93:HOH:O	2.04	0.56
1:L:267:ARG:CB	1:L:267:ARG:CZ	2.75	0.56
2:P:419:GLN:HA	2:P:419:GLN:HE21	1.67	0.56
1:B:114:ILE:O	1:B:115:THR:C	2.44	0.56
1:D:128:HIS:HA	1:D:168:THR:O	2.05	0.56
1:D:195:ILE:HD11	2:H:436:PRO:HA	1.87	0.56
2:M:362:GLU:HG3	4:M:214:HOH:O	2.05	0.56
2:P:512:TRP:CZ3	2:P:554:LEU:HD13	2.40	0.56
2:E:459:ASN:H	2:E:459:ASN:HD22	1.52	0.56
2:G:478:LYS:O	2:G:479:ARG:HB2	2.05	0.56
2:M:487:GLU:OE2	2:N:493:LYS:CE	2.51	0.56
1:A:116:HIS:CD2	2:G:426:PRO:HB2	2.40	0.56
1:D:95:LEU:HB3	1:D:107:ASP:HB2	1.88	0.56
2:F:463:ASN:ND2	2:F:468:ASN:HA	2.20	0.56
1:I:207:PHE:CD1	1:I:217:PHE:CZ	2.94	0.56
1:J:113:LYS:HE2	1:K:212:HIS:O	2.06	0.56
1:J:119:HIS:CE1	2:P:420:ILE:HG21	2.41	0.56
2:O:537:PRO:O	2:O:540:ARG:HB2	2.05	0.56
1:L:293:TRP:CZ3	2:P:336:LEU:HB2	2.41	0.56
2:H:438:CYS:HB2	2:H:439:PRO:HD2	1.87	0.56
1:J:179:VAL:O	1:J:183:ARG:NH2	2.39	0.56
2:N:369:ARG:NH2	4:N:104:HOH:O	1.83	0.56
2:N:505:TYR:C	2:N:508:PRO:HD2	2.25	0.56
2:M:407:LEU:CD2	3:M:760:HDD:HBB2	2.34	0.56
2:E:537:PRO:O	2:E:540:ARG:HB2	2.07	0.55
2:F:541:GLU:O	2:F:545:ASP:HB2	2.05	0.55
2:P:355:ASP:OD1	2:P:358:LYS:HE2	2.05	0.55
1:A:97:ALA:O	1:A:101:GLY:HA3	2.06	0.55
2:E:419:GLN:NE2	2:E:422:ARG:HH11	2.02	0.55
2:N:449[B]:HIS:ND1	2:P:449:HIS:CB	2.70	0.55
2:E:363:GLU:CD	2:E:363:GLU:H	2.10	0.55
1:J:212:HIS:HE1	1:K:109:ILE:HG22	1.72	0.55
2:O:363:GLU:H	2:O:363:GLU:CD	2.10	0.55
2:O:392:HIS:CE1	2:O:412:LEU:O	2.59	0.55
1:D:125:ARG:HB3	3:H:760:HDD:HBD1	1.88	0.55
1:K:199:VAL:HG21	2:O:393:PRO:HD3	1.89	0.55
2:P:448:MET:O	4:P:763:HOH:O	2.18	0.55
1:K:165:ARG:NH1	3:O:760:HDD:CGA	2.68	0.55
1:C:231:GLN:O	1:C:233:GLN:HG3	2.07	0.55
1:L:168:THR:HG22	1:L:183[B]:ARG:NH2	2.22	0.55
1:B:201:ASN:ND2	3:F:760:HDD:HMB2	2.20	0.55

Continued on next page...

Continued from previous page...

Atom-1	Atom-2	Interatomic distance (Å)	Clash overlap (Å)
1:C:281:ASN:ND2	1:C:285:LYS:HB3	2.22	0.55
1:K:95:LEU:HB3	1:K:107:ASP:HB2	1.89	0.55
1:K:201:ASN:ND2	3:O:760:HDD:CMB	2.70	0.55
2:E:493:LYS:HE3	2:F:487:GLU:OE2	2.07	0.55
1:L:260:ARG:HG3	1:L:260:ARG:NH1	2.21	0.55
2:G:392:HIS:HB2	2:G:415:TYR:HB3	1.89	0.54
1:I:127:VAL:HG22	3:M:760:HDD:HMD2	1.90	0.54
1:L:251:HIS:N	4:L:302:HOH:O	2.41	0.54
1:B:128:HIS:HA	1:B:168:THR:O	2.07	0.54
2:F:446:ASP:HB2	1:D:120:GLU:HG2	1.87	0.54
1:I:199:VAL:HB	2:M:411:ARG:NH2	2.22	0.54
2:N:392:HIS:ND1	2:N:415:TYR:HB3	2.04	0.54
2:N:563:GLY:O	2:N:564:ILE:HG13	2.08	0.54
1:B:95:LEU:HB3	1:B:107:ASP:HB2	1.89	0.54
1:C:281:ASN:HD21	1:C:285:LYS:HB3	1.71	0.54
2:G:392:HIS:CG	2:G:415:TYR:CB	2.70	0.54
2:O:392:HIS:CD2	2:O:394:GLY:H	2.25	0.54
2:P:363:GLU:CD	2:P:363:GLU:H	2.11	0.54
1:A:278:ARG:NH2	2:E:487:GLU:OE1	2.38	0.54
2:E:536:ARG:HB3	2:E:539:ILE:HG13	1.89	0.54
2:F:459:ASN:HD22	2:F:459:ASN:N	1.88	0.54
2:G:405:ASP:C	2:G:405:ASP:OD1	2.46	0.54
1:J:246:GLN:O	1:J:249:THR:HG23	2.06	0.54
2:O:457:PRO:O	2:O:465:ILE:CD1	2.55	0.54
1:B:113:LYS:HE2	1:C:212:HIS:O	2.08	0.54
1:B:125:ARG:HB3	3:F:760:HDD:CBD	2.33	0.54
2:F:426:PRO:HB2	1:D:116:HIS:CD2	2.42	0.54
1:C:260:ARG:HH11	1:C:260:ARG:HG3	1.72	0.54
3:N:760:HDD:HMC1	3:N:760:HDD:CBC	2.38	0.54
1:L:181:ASP:HB3	1:L:183[A]:ARG:NH2	2.22	0.54
1:B:144:LEU:HD21	4:F:770:HOH:O	2.07	0.54
2:M:442:ASN:HA	1:K:80:LEU:CD1	2.38	0.54
2:E:528:SER:O	2:E:532:SER:HB3	2.07	0.54
1:D:125:ARG:HG3	1:D:125:ARG:HH11	1.73	0.54
2:E:369:ARG:CG	2:E:369:ARG:NH1	2.70	0.54
2:F:442:ASN:HA	1:D:80:LEU:HD12	1.90	0.54
1:D:251:HIS:CE1	2:H:359:LEU:HD23	2.43	0.54
2:M:449:HIS:CD2	2:O:449:HIS:CD2	2.95	0.54
4:J:303:HOH:O	2:N:393:PRO:HB3	2.08	0.54
1:B:183:ARG:NH2	1:B:261:GLY:O	2.41	0.54
1:C:246:GLN:O	1:C:249:THR:HG23	2.07	0.54

Continued on next page...

Continued from previous page...

Atom-1	Atom-2	Interatomic distance (Å)	Clash overlap (Å)
2:G:461:GLU:HA	2:G:462:PRO:C	2.27	0.54
2:M:509:ARG:HG3	2:M:550:ILE:O	2.08	0.54
2:F:443:PHE:CE1	2:F:461:GLU:HB3	2.43	0.53
2:G:411:ARG:HA	3:G:760:HDD:HBC1	1.89	0.53
2:P:393:PRO:HD2	2:P:415:TYR:CG	2.43	0.53
1:I:200:GLY:HA2	3:M:760:HDD:HMB3	1.90	0.53
2:P:411:ARG:HG2	2:P:415:TYR:HE2	1.73	0.53
2:G:407:LEU:HD11	3:G:760:HDD:HMC2	1.91	0.53
1:J:126:ILE:HD11	1:K:118:ASP:O	2.07	0.53
2:H:382:PHE:CE1	2:H:386:ASN:ND2	2.77	0.53
1:I:128:HIS:CE1	1:I:169:VAL:HG22	2.43	0.53
1:K:165:ARG:HD3	3:O:760:HDD:O1A	2.08	0.53
1:C:155:ASP:OD2	1:C:157:ASN:N	2.33	0.53
1:I:272:PHE:C	1:I:274:ILE:H	2.12	0.53
2:N:563:GLY:C	2:N:564:ILE:HG13	2.29	0.53
1:K:179:VAL:O	1:K:183:ARG:NH2	2.42	0.53
1:B:267[B]:ARG:HH22	2:F:330:ASP:CB	2.03	0.53
1:I:106:GLU:O	1:I:108:PHE:N	2.42	0.53
2:M:407:LEU:CD2	3:M:760:HDD:CBB	2.86	0.53
2:O:414:SER:HB2	3:O:760:HDD:CBC	2.38	0.53
1:A:77:ASN:HB3	2:G:469:TRP:CE3	2.44	0.53
2:F:470:PRO:HB3	1:D:78:TYR:O	2.09	0.53
1:I:128:HIS:HA	1:I:168:THR:O	2.07	0.53
2:M:446:ASP:HB2	1:K:120:GLU:HG2	1.90	0.53
1:L:125:ARG:HB3	1:L:127:VAL:O	2.09	0.53
1:C:222:LYS:HB3	1:C:223:PRO:HD2	1.90	0.53
2:O:392:HIS:O	2:O:395:HIS:HB2	2.08	0.53
2:O:396:ILE:HD13	2:O:402:PHE:CE2	2.44	0.53
2:P:538:TYR:HA	2:P:541:GLU:CG	2.38	0.53
1:A:119:HIS:HB2	2:G:426:PRO:HG3	1.90	0.53
1:B:116:HIS:CD2	2:H:426:PRO:HB2	2.43	0.53
1:I:142:LYS:HA	1:I:156:PRO:HG3	1.89	0.53
1:I:213:LYS:HD3	1:L:92:GLN:HA	1.91	0.53
2:O:457:PRO:HA	4:O:764:HOH:O	2.09	0.53
1:B:165:ARG:HD3	3:F:760:HDD:CGA	2.31	0.52
1:B:179:VAL:O	1:B:183:ARG:NH2	2.37	0.52
1:B:206:PHE:CD2	3:F:760:HDD:CBB	2.92	0.52
1:I:213:LYS:NZ	2:N:461:GLU:O	2.36	0.52
2:N:356:PRO:HG3	2:N:407:LEU:HB2	1.90	0.52
1:L:201:ASN:CG	3:P:760:HDD:HMB2	2.30	0.52
2:P:351:PHE:HB2	2:P:358:LYS:HD2	1.90	0.52

Continued on next page...

Continued from previous page...

Atom-1	Atom-2	Interatomic distance (Å)	Clash overlap (Å)
2:G:512:TRP:CZ3	2:G:554:LEU:HD13	2.44	0.52
1:I:125:ARG:CB	3:M:760:HDD:HBD1	2.33	0.52
1:K:76:GLU:HG3	1:K:78:TYR:CE2	2.44	0.52
2:O:445:ARG:HB3	2:O:446:ASP:OD1	2.09	0.52
1:A:206:PHE:HD1	2:E:407:LEU:HD21	1.75	0.52
2:F:392:HIS:ND1	2:F:415:TYR:CG	2.74	0.52
1:D:76:GLU:HG3	1:D:78:TYR:CE2	2.44	0.52
1:I:222:LYS:HB3	1:I:223:PRO:HD2	1.91	0.52
2:N:538:TYR:HA	2:N:541:GLU:HG3	1.92	0.52
1:K:281:ASN:OD1	1:K:281:ASN:C	2.47	0.52
2:E:509:ARG:HD2	2:E:550:ILE:O	2.09	0.52
1:D:136:GLY:HA3	2:H:374:VAL:O	2.09	0.52
1:L:260:ARG:HG3	1:L:260:ARG:HH11	1.74	0.52
1:B:119:HIS:CE1	2:H:420:ILE:HG21	2.45	0.52
1:D:266:TYR:H	1:D:267[B]:ARG:HH22	1.57	0.52
1:I:251:HIS:HE1	2:M:359:LEU:HD23	1.73	0.52
1:C:128:HIS:HA	1:C:168:THR:O	2.09	0.52
1:I:76:GLU:HG3	1:I:78:TYR:CE2	2.44	0.52
2:O:438:CYS:HB2	2:O:439:PRO:CD	2.40	0.52
1:D:76:GLU:OE1	1:D:77:ASN:N	2.43	0.52
3:M:760:HDD:HMC1	3:M:760:HDD:CBC	2.39	0.52
1:J:229:ILE:HD11	2:O:319:ARG:HG2	1.92	0.52
2:O:392:HIS:HE1	2:O:412:LEU:O	1.93	0.52
1:A:214:PHE:CD1	3:E:760:HDD:CAC	2.93	0.52
2:F:433:ILE:HG13	2:F:433:ILE:O	2.08	0.52
4:C:317:HOH:O	2:G:343:GLU:OE2	2.19	0.52
1:K:206:PHE:CD1	2:O:407:LEU:HD21	2.45	0.52
2:G:563:GLY:C	2:G:564:ILE:HG13	2.29	0.52
2:H:443:PHE:HB3	2:H:459:ASN:O	2.08	0.52
1:L:177:ASP:O	1:L:183[B]:ARG:NH1	2.42	0.52
2:H:361:PRO:HG2	2:H:364:LEU:HD12	1.91	0.51
1:J:278:ARG:HH22	2:N:487:GLU:CD	2.09	0.51
1:L:128:HIS:HA	1:L:168:THR:O	2.09	0.51
1:B:125:ARG:HG2	3:F:760:HDD:HBD1	1.92	0.51
1:C:201:ASN:ND2	3:G:760:HDD:HMB2	2.25	0.51
1:B:273:GLY:O	1:B:275:HIS:N	2.42	0.51
2:F:459:ASN:H	2:F:459:ASN:ND2	1.97	0.51
1:C:251:HIS:CE1	2:G:359:LEU:HD23	2.45	0.51
2:M:340:LEU:C	2:M:341:ILE:HG13	2.31	0.51
2:N:448:MET:CG	2:N:449[B]:HIS:CD2	2.91	0.51
2:N:459:ASN:HD22	2:N:459:ASN:N	2.07	0.51

Continued on next page...

Continued from previous page...

Atom-1	Atom-2	Interatomic distance (Å)	Clash overlap (Å)
1:B:267[B]:ARG:CG	1:B:267[B]:ARG:NH1	2.72	0.51
1:C:127:VAL:HG23	3:G:760:HDD:HAD1	1.92	0.51
1:I:201:ASN:ND2	3:M:760:HDD:HMB2	2.26	0.51
2:O:443:PHE:CZ	2:O:470:PRO:HD2	2.46	0.51
2:O:515:GLN:HB2	2:O:520:GLN:HG2	1.92	0.51
2:E:438:CYS:HB2	2:E:439:PRO:CD	2.40	0.51
1:B:206:PHE:CD2	3:F:760:HDD:HBB1	2.44	0.51
2:G:382:PHE:CE1	2:G:386:ASN:ND2	2.78	0.51
2:M:382:PHE:O	2:M:386:ASN:HB3	2.11	0.51
2:N:443:PHE:CZ	2:N:470:PRO:HD2	2.46	0.51
1:C:214:PHE:HB3	1:C:215:PRO:CD	2.38	0.51
2:H:461:GLU:OE2	2:H:461:GLU:C	2.49	0.51
1:I:122:ILE:HB	1:I:123:PRO:CD	2.41	0.51
1:B:119:HIS:HB2	2:H:426:PRO:HG3	1.93	0.51
1:B:214:PHE:HB3	1:B:215:PRO:HD3	1.91	0.51
2:H:392:HIS:CD2	2:H:394:GLY:H	2.28	0.51
1:C:242:TYR:O	1:C:243:VAL:C	2.46	0.51
2:M:361:PRO:HG2	2:M:364:LEU:HD12	1.92	0.51
2:O:392:HIS:CB	2:O:415:TYR:HB3	2.39	0.51
1:C:207:PHE:CD1	1:C:217:PHE:HZ	2.28	0.51
1:C:290:ARG:CD	4:C:314:HOH:O	2.58	0.51
1:D:275:HIS:CG	2:H:408:LEU:HB2	2.46	0.51
2:H:419:GLN:NE2	2:H:419:GLN:CA	2.65	0.51
2:M:411:ARG:HG3	3:M:760:HDD:HMC3	1.91	0.51
1:J:212:HIS:O	1:K:113:LYS:HE2	2.10	0.51
1:A:76:GLU:OE1	1:A:77:ASN:N	2.44	0.51
1:A:188:LYS:HG3	1:A:197:ASP:OD2	2.11	0.51
2:H:369:ARG:HG2	2:H:369:ARG:HH11	1.75	0.51
1:K:214:PHE:CD1	3:O:760:HDD:HAC	2.46	0.51
2:O:414:SER:HB2	3:O:760:HDD:HBC2	1.93	0.51
2:F:369:ARG:HH11	2:F:369:ARG:CG	2.25	0.50
3:N:760:HDD:HBC1	3:N:760:HDD:CMC	2.33	0.50
2:G:459:ASN:HD22	2:G:459:ASN:H	1.58	0.50
1:I:138:PHE:C	1:I:138:PHE:CD2	2.85	0.50
1:I:273:GLY:CA	4:I:303:HOH:O	2.59	0.50
2:M:469:TRP:HA	2:M:470:PRO:C	2.31	0.50
1:K:128:HIS:CD2	3:O:760:HDD:C1A	2.94	0.50
2:P:544:VAL:HG11	2:P:559:ALA:HB2	1.93	0.50
1:A:126:ILE:HD11	1:D:118:ASP:O	2.11	0.50
2:F:426:PRO:HG3	1:D:119:HIS:HB2	1.93	0.50
1:J:213:LYS:O	1:J:214:PHE:C	2.50	0.50

Continued on next page...

Continued from previous page...

Atom-1	Atom-2	Interatomic distance (Å)	Clash overlap (Å)
2:N:536:ARG:HB3	2:N:539:ILE:HG13	1.92	0.50
2:O:339:GLN:HE22	2:O:360:ILE:HG22	1.76	0.50
1:D:247:PRO:O	1:D:248:GLU:C	2.50	0.50
1:D:275:HIS:HB2	1:D:277:PHE:CE2	2.46	0.50
1:I:276:THR:O	2:M:403:THR:HG21	2.11	0.50
1:J:249:THR:O	1:J:253:VAL:HG23	2.12	0.50
2:N:429:HIS:CD2	1:L:83:ASN:HB3	2.47	0.50
1:K:213:LYS:NZ	2:P:461:GLU:O	2.42	0.50
2:P:493:LYS:O	2:P:494:VAL:CG1	2.59	0.50
1:D:122:ILE:HB	1:D:123:PRO:HD2	1.94	0.50
1:D:251:HIS:HE1	2:H:359:LEU:HD23	1.76	0.50
2:N:363:GLU:CD	2:N:363:GLU:H	2.15	0.50
1:K:251:HIS:CE1	2:O:359:LEU:HD23	2.46	0.50
2:M:469:TRP:NE1	2:M:471:ARG:NH1	2.60	0.50
1:C:211:ALA:CB	2:G:410:GLY:HA3	2.41	0.50
1:J:86:VAL:HA	4:J:305:HOH:O	2.11	0.50
1:J:138:PHE:C	1:J:138:PHE:CD2	2.84	0.50
2:N:449[B]:HIS:ND1	2:P:449:HIS:CG	2.79	0.50
1:L:274:ILE:HD12	3:P:760:HDD:HMB1	1.93	0.50
2:P:352:ASP:HB2	2:P:500:SER:HB2	1.94	0.50
2:P:469:TRP:CE3	2:P:471:ARG:HG3	2.47	0.50
2:E:507:HIS:N	2:E:508:PRO:HD2	2.27	0.50
1:B:212:HIS:NE2	1:C:91:ASP:OD2	2.45	0.50
2:M:357:THR:O	2:M:358[A]:LYS:HD3	2.11	0.50
1:L:185:PHE:CD1	1:L:185:PHE:C	2.85	0.50
1:L:222:LYS:HD3	1:L:223:PRO:HD2	1.93	0.50
1:A:229:ILE:HG23	1:A:230:PRO:HA	1.93	0.50
2:E:538:TYR:HA	2:E:541:GLU:HG2	1.93	0.50
2:F:469:TRP:CE3	1:D:77:ASN:HB3	2.46	0.50
1:C:97:ALA:O	1:C:101:GLY:HA3	2.12	0.50
1:K:147:ILE:C	1:K:281:ASN:HB3	2.32	0.50
1:K:206:PHE:HD1	2:O:407:LEU:HD21	1.76	0.50
1:A:207:PHE:CD1	1:A:217:PHE:CZ	3.00	0.49
2:E:392:HIS:CD2	2:E:394:GLY:N	2.80	0.49
1:B:133:ALA:HA	1:B:164:VAL:O	2.12	0.49
1:B:267[B]:ARG:HH11	1:B:267[B]:ARG:HG3	1.77	0.49
2:F:488:ARG:HD2	4:F:761:HOH:O	1.97	0.49
2:G:446:ASP:OD1	2:G:446:ASP:N	2.42	0.49
2:M:411:ARG:HD2	3:M:760:HDD:CHC	2.42	0.49
1:L:185:PHE:C	1:L:185:PHE:HD1	2.14	0.49
2:E:524:VAL:HG13	2:E:558:VAL:HG22	1.95	0.49

Continued on next page...

Continued from previous page...

Atom-1	Atom-2	Interatomic distance (Å)	Clash overlap (Å)
2:F:449:HIS:HD2	2:H:449[A]:HIS:HD2	1.55	0.49
1:D:144:LEU:O	1:D:146:ASP:N	2.45	0.49
2:N:352:ASP:HB2	2:N:500:SER:HB2	1.94	0.49
1:L:168:THR:HG23	1:L:183[B]:ARG:NH2	2.27	0.49
1:J:251:HIS:CE1	2:N:359:LEU:HD23	2.47	0.49
1:K:178:THR:O	2:O:311:THR:HG22	2.11	0.49
2:P:405:ASP:C	2:P:405:ASP:OD1	2.50	0.49
1:A:206:PHE:CD1	2:E:407:LEU:HD21	2.47	0.49
1:I:205:ILE:HD13	1:I:205:ILE:H	1.77	0.49
1:I:276:THR:O	2:M:403:THR:HG23	2.12	0.49
2:E:473:THR:N	4:E:93:HOH:O	2.45	0.49
4:E:148:HOH:O	1:C:106:GLU:HG2	2.12	0.49
1:I:278:ARG:HH22	2:M:487:GLU:CD	2.15	0.49
1:A:213:LYS:NZ	2:F:461:GLU:O	2.27	0.49
2:G:492:ASN:O	2:G:494:VAL:HG22	2.13	0.49
1:J:265:SER:OG	1:J:267:ARG:HG3	2.13	0.49
1:K:221:VAL:HG23	1:K:239:PHE:CD1	2.48	0.49
1:A:138:PHE:CD2	1:A:139:GLN:N	2.81	0.49
1:D:206:PHE:CD1	3:H:760:HDD:HBB2	2.48	0.49
1:I:143:SER:OG	1:I:145:SER:HB3	2.13	0.49
2:O:351:PHE:CD1	2:O:351:PHE:C	2.86	0.49
2:P:516:THR:O	2:P:520:GLN:HG3	2.12	0.49
1:I:247:PRO:HB2	2:M:504:TYR:CD2	2.47	0.49
2:N:411:ARG:NE	3:N:760:HDD:C4B	2.75	0.49
2:N:512:TRP:CZ3	2:N:554:LEU:HD13	2.47	0.49
2:O:433:ILE:O	2:O:433:ILE:HG13	2.12	0.49
1:L:138:PHE:C	1:L:138:PHE:CD2	2.86	0.49
2:E:536:ARG:HG2	2:E:538:TYR:CE2	2.48	0.48
1:B:190:TYR:HE1	4:F:771:HOH:O	1.95	0.48
1:D:143:SER:OG	1:D:145:SER:HB3	2.13	0.48
1:K:183:ARG:NH2	1:K:261:GLY:O	2.46	0.48
1:L:125:ARG:HB2	1:L:129:ALA:HA	1.94	0.48
2:G:507:HIS:N	2:G:508:PRO:CD	2.76	0.48
2:M:405:ASP:OD1	2:M:405:ASP:C	2.52	0.48
2:G:438:CYS:HB2	2:G:439:PRO:CD	2.40	0.48
1:I:275:HIS:CG	2:M:408:LEU:HB2	2.48	0.48
2:M:538:TYR:HA	2:M:541:GLU:HG2	1.95	0.48
2:P:419:GLN:NE2	2:P:419:GLN:CA	2.66	0.48
1:A:142:LYS:HA	1:A:156:PRO:HG3	1.94	0.48
1:A:214:PHE:CD1	3:E:760:HDD:HAC	2.48	0.48
1:A:222:LYS:O	1:A:223:PRO:C	2.52	0.48

Continued on next page...

Continued from previous page...

Atom-1	Atom-2	Interatomic distance (Å)	Clash overlap (Å)
2:G:355:ASP:OD2	2:G:357:THR:OG1	2.31	0.48
2:H:433:ILE:O	2:H:433:ILE:HG13	2.13	0.48
2:M:564:ILE:HG22	2:M:564:ILE:O	2.13	0.48
2:O:493:LYS:O	2:O:494:VAL:HG13	2.12	0.48
2:P:461:GLU:OE2	2:P:462:PRO:N	2.47	0.48
1:B:197:ASP:HB2	2:F:395:HIS:HB2	1.95	0.48
1:B:207:PHE:CD1	1:B:217:PHE:CZ	3.02	0.48
1:B:246:GLN:O	1:B:249:THR:HG23	2.13	0.48
2:M:323:TRP:CZ3	2:M:378:ASN:HB3	2.49	0.48
2:N:411:ARG:O	2:N:415:TYR:HD2	1.97	0.48
2:N:537:PRO:O	2:N:541:GLU:HG2	2.12	0.48
2:O:460:TYR:N	2:O:460:TYR:CD2	2.80	0.48
2:P:493:LYS:C	2:P:494:VAL:HG13	2.33	0.48
2:E:429:HIS:CD2	1:C:83:ASN:HB3	2.49	0.48
2:F:449:HIS:CG	2:H:449[A]:HIS:CD2	3.01	0.48
1:D:214:PHE:CB	1:D:215:PRO:HD3	2.43	0.48
2:O:493:LYS:CE	2:P:487:GLU:OE2	2.61	0.48
1:L:229:ILE:CG2	1:L:230:PRO:HA	2.43	0.48
2:P:443:PHE:CZ	2:P:470:PRO:HD2	2.49	0.48
2:E:490:GLU:HG2	2:F:490:GLU:HG2	1.95	0.48
1:B:267[B]:ARG:NH2	2:F:330:ASP:CB	2.60	0.48
2:F:416:THR:CG2	2:F:417:ASP:N	2.77	0.48
1:C:125:ARG:CB	3:G:760:HDD:HBD1	2.41	0.48
1:D:265:SER:HB2	1:D:267[B]:ARG:NE	2.29	0.48
1:I:222:LYS:NZ	1:L:121:ARG:HH21	2.12	0.48
1:K:294:LYS:HD3	1:K:295:PRO:N	2.27	0.48
2:O:339:GLN:NE2	2:O:360:ILE:HG22	2.29	0.48
2:E:449[A]:HIS:CD2	2:E:451:MET:SD	3.06	0.48
2:E:563:GLY:C	2:E:564:ILE:HG13	2.33	0.48
1:B:213:LYS:HD3	1:C:92:GLN:HA	1.96	0.48
2:F:505:TYR:C	2:F:508:PRO:HD2	2.33	0.48
2:M:516:THR:O	2:M:517:PRO:C	2.51	0.48
2:N:531:LEU:HA	2:N:534:VAL:HG23	1.96	0.48
1:K:260:ARG:HH22	1:K:270:GLU:HG3	1.78	0.48
3:O:760:HDD:HBA2	3:O:760:HDD:HMA3	1.94	0.48
2:P:359:LEU:O	2:P:361:PRO:HD3	2.14	0.48
2:H:335:GLU:HA	2:H:371:GLY:O	2.13	0.48
2:O:538:TYR:HA	2:O:541:GLU:HG2	1.95	0.48
2:P:473:THR:O	2:P:481:GLY:HA3	2.13	0.48
2:F:411:ARG:NE	2:F:415:TYR:OH	2.38	0.48
1:C:76:GLU:OE2	1:C:76:GLU:CA	2.62	0.48

Continued on next page...

Continued from previous page...

Atom-1	Atom-2	Interatomic distance (Å)	Clash overlap (Å)
1:K:189:PHE:CD1	1:K:196:PHE:HD2	2.32	0.48
1:B:125:ARG:HA	4:B:306:HOH:O	2.13	0.47
2:F:382:PHE:O	2:F:386:ASN:HB3	2.14	0.47
1:K:265:SER:OG	1:K:267:ARG:HB2	2.14	0.47
2:O:493:LYS:NZ	2:P:487:GLU:OE2	2.46	0.47
2:P:556:GLN:O	2:P:557:ALA:C	2.52	0.47
2:E:405:ASP:C	2:E:405:ASP:OD1	2.53	0.47
1:C:289:VAL:HG22	1:C:290:ARG:N	2.28	0.47
1:I:120:GLU:HB3	1:I:121:ARG:NH1	2.29	0.47
2:N:459:ASN:H	2:N:459:ASN:ND2	2.12	0.47
1:K:246:GLN:O	1:K:249:THR:HG23	2.14	0.47
1:L:260:ARG:HH11	1:L:260:ARG:CG	2.28	0.47
1:I:222:LYS:HB3	1:I:223:PRO:CD	2.44	0.47
2:O:416:THR:CG2	2:O:417:ASP:N	2.75	0.47
2:O:462:PRO:HA	2:O:468:ASN:OD1	2.15	0.47
2:M:495:ARG:HD2	4:M:129:HOH:O	2.15	0.47
1:J:249:THR:O	1:J:250:LEU:C	2.50	0.47
1:J:290:ARG:CD	2:N:360:ILE:HD12	2.44	0.47
1:K:189:PHE:CD1	1:K:196:PHE:CD2	3.03	0.47
1:A:185:PHE:C	1:A:185:PHE:HD1	2.18	0.47
1:B:206:PHE:CG	1:B:207:PHE:N	2.82	0.47
2:H:411:ARG:HG3	3:H:760:HDD:HMC3	1.96	0.47
2:H:431:ILE:CG2	2:H:432:PRO:HD2	2.45	0.47
2:M:460:TYR:N	2:M:460:TYR:CD2	2.83	0.47
1:J:279:LEU:O	1:J:280:ILE:HD13	2.14	0.47
2:O:505:TYR:C	2:O:508:PRO:HD2	2.35	0.47
1:A:185:PHE:C	1:A:185:PHE:CD1	2.87	0.47
2:F:449:HIS:HB2	2:H:449[B]:HIS:NE2	2.30	0.47
2:M:449:HIS:CD2	2:O:449:HIS:HD2	2.32	0.47
2:M:490:GLU:HG2	2:N:490:GLU:HG2	1.96	0.47
2:O:460:TYR:CE2	1:L:238:THR:HG22	2.49	0.47
2:P:528:SER:O	2:P:532:SER:HB3	2.15	0.47
2:G:507:HIS:N	2:G:508:PRO:HD2	2.29	0.47
1:J:121:ARG:NH2	1:K:222:LYS:HE3	2.30	0.47
1:K:197:ASP:HB2	2:O:395:HIS:HB2	1.95	0.47
1:K:260:ARG:NH2	1:K:270:GLU:HG3	2.29	0.47
2:O:433:ILE:HG23	2:O:434:ASN:OD1	2.14	0.47
2:F:515:GLN:HB2	2:F:520:GLN:HG2	1.97	0.47
2:M:357:THR:C	2:M:358[A]:LYS:HD3	2.35	0.47
1:L:249:THR:O	1:L:253:VAL:HG23	2.15	0.47
2:E:404:ASN:ND2	1:D:101:GLY:HA2	2.29	0.47

Continued on next page...

Continued from previous page...

Atom-1	Atom-2	Interatomic distance (Å)	Clash overlap (Å)
1:B:267[B]:ARG:NH2	2:F:330:ASP:O	2.43	0.47
1:K:275:HIS:CG	2:O:408:LEU:HB2	2.49	0.47
1:L:97:ALA:O	1:L:101:GLY:HA3	2.15	0.47
1:A:275:HIS:CG	2:E:408:LEU:HB2	2.50	0.47
1:C:188:LYS:HB2	1:C:188:LYS:HE2	1.74	0.47
2:G:544:VAL:O	2:G:547:LEU:HB2	2.14	0.47
2:M:459:ASN:HD22	2:M:459:ASN:N	2.05	0.47
1:L:251:HIS:CE1	2:P:359:LEU:HD23	2.49	0.47
1:J:119:HIS:HB2	2:P:426:PRO:HG3	1.96	0.46
1:K:183:ARG:O	1:K:201:ASN:CB	2.59	0.46
1:K:247:PRO:O	1:K:249:THR:N	2.48	0.46
1:L:127:VAL:HA	4:L:301:HOH:O	2.14	0.46
1:I:97:ALA:O	1:I:101:GLY:HA3	2.15	0.46
2:P:355:ASP:HA	2:P:501:PHE:CE2	2.50	0.46
2:P:493:LYS:O	2:P:494:VAL:HG13	2.15	0.46
2:E:531:LEU:HA	2:E:534:VAL:HG23	1.98	0.46
1:I:80:LEU:CD1	2:O:442:ASN:HA	2.45	0.46
1:I:81:THR:OG1	2:O:440:TYR:HA	2.16	0.46
2:M:507:HIS:N	2:M:508:PRO:CD	2.79	0.46
1:J:293:TRP:CZ3	2:N:336:LEU:HB2	2.51	0.46
2:P:538:TYR:HA	2:P:541:GLU:HG3	1.97	0.46
2:H:459:ASN:H	2:H:459:ASN:HD22	1.63	0.46
1:I:275:HIS:CD2	2:M:408:LEU:HB2	2.51	0.46
2:N:386:ASN:O	2:N:387:GLU:C	2.52	0.46
2:N:472:GLU:HG2	4:N:136:HOH:O	2.15	0.46
1:K:205:ILE:HB	2:O:356:PRO:O	2.14	0.46
2:P:461:GLU:OE2	2:P:461:GLU:C	2.54	0.46
2:E:419:GLN:NE2	2:E:422:ARG:NH1	2.62	0.46
2:E:433:ILE:HG13	2:E:433:ILE:O	2.16	0.46
1:C:155:ASP:OD2	1:C:155:ASP:C	2.54	0.46
2:P:537:PRO:O	2:P:540:ARG:HB2	2.16	0.46
1:A:212:HIS:O	1:D:113:LYS:CE	2.58	0.46
2:F:509:ARG:CG	2:F:509:ARG:NH1	2.68	0.46
1:C:185:PHE:HD1	1:C:185:PHE:C	2.19	0.46
2:G:369:ARG:CG	2:G:369:ARG:NH1	2.69	0.46
2:G:456:ASN:OD1	2:G:457:PRO:HD2	2.16	0.46
2:M:355:ASP:OD1	2:M:358[B]:LYS:CE	2.63	0.46
2:M:411:ARG:O	2:M:415:TYR:HD2	1.98	0.46
2:M:461:GLU:C	2:M:461:GLU:CD	2.74	0.46
2:N:405:ASP:C	2:N:405:ASP:OD1	2.54	0.46
1:K:278:ARG:NH2	2:O:487:GLU:CD	2.67	0.46

Continued on next page...

Continued from previous page...

Atom-1	Atom-2	Interatomic distance (Å)	Clash overlap (Å)
1:L:278:ARG:HH22	2:P:487:GLU:CD	2.18	0.46
1:A:275:HIS:CD2	2:E:408:LEU:HB2	2.51	0.46
1:C:185:PHE:C	1:C:185:PHE:CD1	2.89	0.46
1:C:214:PHE:CD1	3:G:760:HDD:HAC	2.51	0.46
2:M:516:THR:O	2:M:519:GLU:N	2.48	0.46
1:J:92:GLN:NE2	2:P:472:GLU:OE2	2.49	0.46
1:J:116:HIS:CD2	2:P:426:PRO:HB2	2.50	0.46
1:K:155:ASP:OD2	1:K:157:ASN:HB2	2.15	0.46
2:P:392:HIS:HD2	2:P:394:GLY:N	2.09	0.46
1:D:206:PHE:CG	1:D:207:PHE:N	2.84	0.46
2:H:407:LEU:CD2	3:H:760:HDD:HBB2	2.45	0.46
1:I:131:GLY:HA3	1:I:165:ARG:CZ	2.46	0.46
2:M:380:ASP:N	2:M:385:GLU:OE2	2.37	0.46
1:J:229:ILE:HG23	1:J:230:PRO:HA	1.98	0.46
2:O:331:PHE:N	2:O:331:PHE:CD2	2.81	0.46
1:A:119:HIS:CE1	2:G:420:ILE:HG21	2.51	0.46
1:A:234:SER:HB2	1:A:239:PHE:CD2	2.51	0.46
1:A:241:ASP:O	1:A:245:LEU:HD12	2.16	0.46
1:D:140:PRO:O	1:D:156:PRO:HB3	2.16	0.46
1:D:197:ASP:HB2	2:H:392:HIS:O	2.16	0.46
2:N:316:ASP:O	2:N:317:PHE:C	2.53	0.46
2:E:461:GLU:HA	2:E:462:PRO:C	2.36	0.45
2:G:309:LYS:CB	2:G:311:THR:CG2	2.76	0.45
2:G:411:ARG:HG2	2:G:415:TYR:HE2	1.80	0.45
2:N:355:ASP:OD1	2:N:358:LYS:CE	2.61	0.45
1:L:207:PHE:CD1	1:L:217:PHE:CZ	3.04	0.45
1:L:280:ILE:HD13	1:L:280:ILE:N	2.30	0.45
1:A:211:ALA:CB	2:E:410:GLY:HA3	2.46	0.45
1:C:278:ARG:NH2	2:G:487:GLU:OE1	2.39	0.45
1:I:101:GLY:HA2	2:P:404:ASN:ND2	2.31	0.45
1:I:182:ILE:C	1:I:183:ARG:HD2	2.36	0.45
2:P:392:HIS:ND1	2:P:415:TYR:CA	2.68	0.45
1:B:211:ALA:CB	2:F:410:GLY:HA3	2.47	0.45
2:F:316:ASP:O	2:F:317:PHE:C	2.54	0.45
2:F:340:LEU:C	2:F:341:ILE:HG13	2.36	0.45
2:G:351:PHE:HB2	2:G:358:LYS:HD2	1.96	0.45
2:G:392:HIS:CD2	2:G:394:GLY:N	2.84	0.45
2:H:356:PRO:HG3	2:H:407:LEU:HB2	1.98	0.45
2:M:407:LEU:HD23	3:M:760:HDD:CBB	2.37	0.45
1:J:229:ILE:CG2	1:J:230:PRO:HA	2.46	0.45
1:J:230:PRO:HG2	1:J:233:GLN:HB2	1.98	0.45

Continued on next page...

Continued from previous page...

Atom-1	Atom-2	Interatomic distance (Å)	Clash overlap (Å)
2:O:369:ARG:HG2	2:O:369:ARG:HH11	1.81	0.45
2:O:402:PHE:HB3	2:O:408:LEU:HD21	1.97	0.45
3:P:760:HDD:HBB	3:P:760:HDD:HMA1	1.87	0.45
2:G:536:ARG:HA	2:G:537:PRO:HD3	1.78	0.45
1:J:89:ALA:HA	2:P:473:THR:O	2.17	0.45
2:N:446:ASP:HB2	1:L:120:GLU:HG2	1.99	0.45
1:K:81:THR:HB	1:K:86:VAL:O	2.17	0.45
2:P:393:PRO:HD2	2:P:415:TYR:CD2	2.52	0.45
1:B:120:GLU:HB3	1:B:121:ARG:NH1	2.31	0.45
1:D:265:SER:OG	1:D:267[A]:ARG:HG3	2.17	0.45
1:A:128:HIS:HA	1:A:168:THR:O	2.17	0.45
1:B:77:ASN:HB3	2:H:469:TRP:CH2	2.51	0.45
2:F:323:TRP:CH2	2:F:378:ASN:HB3	2.51	0.45
2:M:443:PHE:CE2	2:M:460:TYR:O	2.69	0.45
1:K:136:GLY:CA	2:O:374:VAL:O	2.65	0.45
2:P:391:PHE:CD2	2:P:391:PHE:N	2.85	0.45
2:F:392:HIS:HB2	2:F:415:TYR:HB3	1.97	0.45
1:D:229:ILE:HG23	1:D:230:PRO:HA	1.98	0.45
2:H:410:GLY:O	2:H:411:ARG:C	2.55	0.45
2:M:463:ASN:ND2	2:M:468:ASN:HA	2.31	0.45
1:J:125:ARG:HA	4:J:309:HOH:O	2.16	0.45
2:P:524:VAL:HG13	2:P:558:VAL:CG2	2.47	0.45
3:P:760:HDD:HBC1	3:P:760:HDD:HMC1	1.98	0.45
3:E:760:HDD:HMD1	3:E:760:HDD:HAD2	1.48	0.45
1:B:115:THR:O	1:B:118:ASP:HB2	2.17	0.45
2:F:414:SER:OG	3:F:760:HDD:HBC1	2.16	0.45
2:F:564:ILE:HG22	2:F:564:ILE:O	2.17	0.45
1:I:131:GLY:HA3	1:I:165:ARG:NH2	2.32	0.45
1:I:196:PHE:HA	2:M:395:HIS:O	2.17	0.45
1:J:274:ILE:HD12	3:N:760:HDD:HMB1	1.98	0.45
2:P:459:ASN:N	2:P:459:ASN:ND2	2.44	0.45
2:H:323:TRP:CZ3	2:H:378:ASN:HB3	2.51	0.45
1:J:178:THR:O	2:N:311:THR:HG22	2.17	0.45
1:J:290:ARG:HD2	2:N:360:ILE:HD12	1.98	0.45
2:N:355:ASP:OD1	2:N:358:LYS:CG	2.65	0.45
1:K:133:ALA:HA	1:K:164:VAL:O	2.17	0.45
2:M:443:PHE:HA	2:M:445:ARG:HH12	1.82	0.45
2:M:462:PRO:HA	2:M:468:ASN:OD1	2.17	0.45
1:J:158:LYS:HE2	1:J:192:GLU:OE1	2.17	0.45
1:J:247:PRO:HB2	2:N:504:TYR:CD2	2.52	0.45
2:O:442:ASN:OD1	2:O:444:GLN:HB2	2.17	0.45

Continued on next page...

Continued from previous page...

Atom-1	Atom-2	Interatomic distance (Å)	Clash overlap (Å)
2:F:411:ARG:HG3	3:F:760:HDD:HMC3	2.00	0.44
1:D:205:ILE:HD12	1:D:251:HIS:CE1	2.53	0.44
1:I:78:TYR:O	2:O:470:PRO:HB3	2.17	0.44
2:P:353:LEU:HD23	2:P:353:LEU:HA	1.79	0.44
1:A:227:TRP:O	2:H:319:ARG:HD3	2.17	0.44
2:E:404:ASN:O	2:E:405:ASP:C	2.53	0.44
1:B:251:HIS:CE1	2:F:359:LEU:HD23	2.52	0.44
2:M:472:GLU:H	2:M:472:GLU:HG2	1.32	0.44
1:J:91:ASP:OD2	1:K:212:HIS:NE2	2.50	0.44
2:O:392:HIS:CB	2:O:415:TYR:CB	2.96	0.44
2:O:459:ASN:HD22	2:O:459:ASN:N	2.09	0.44
2:P:461:GLU:C	2:P:461:GLU:CD	2.76	0.44
2:P:469:TRP:HA	2:P:470:PRO:C	2.37	0.44
2:P:503:GLU:OE2	2:P:506:SER:OG	2.27	0.44
1:B:165:ARG:CD	3:F:760:HDD:O1A	2.34	0.44
2:G:419:GLN:HE21	2:G:419:GLN:CA	2.20	0.44
2:M:449:HIS:HD2	2:O:449:HIS:HD2	1.66	0.44
1:J:252:ASN:HD22	1:J:252:ASN:HA	1.64	0.44
1:J:275:HIS:CG	2:N:408:LEU:HB2	2.52	0.44
1:K:188:LYS:NZ	1:K:197:ASP:OD2	2.42	0.44
1:L:207:PHE:CD2	1:L:252:ASN:HB3	2.52	0.44
1:I:182:ILE:O	1:I:183:ARG:HD2	2.18	0.44
1:J:228:ALA:HB2	2:O:382:PHE:CG	2.52	0.44
2:O:490:GLU:CG	2:P:490:GLU:HG2	2.47	0.44
2:F:513:LEU:HD23	2:F:513:LEU:HA	1.84	0.44
1:C:191:THR:OG1	1:C:194:GLY:O	2.30	0.44
1:I:106:GLU:HB3	2:O:412:LEU:HD12	1.99	0.44
2:M:363:GLU:H	2:M:363:GLU:CD	2.21	0.44
2:M:419:GLN:NE2	2:M:419:GLN:CA	2.75	0.44
1:L:183[B]:ARG:HH11	2:P:318:HIS:HE1	1.63	0.44
1:A:152:PHE:CE1	1:A:153:LEU:HD21	2.53	0.44
1:B:193:GLU:OE1	2:F:479:ARG:HD3	2.17	0.44
2:H:331:PHE:CD2	2:H:331:PHE:N	2.85	0.44
2:M:538:TYR:HA	2:M:541:GLU:CG	2.47	0.44
1:J:246:GLN:O	1:J:248:GLU:N	2.50	0.44
1:L:114:ILE:HD13	1:L:114:ILE:HA	1.81	0.44
1:L:199:VAL:HB	2:P:411:ARG:NH2	2.33	0.44
1:C:251:HIS:HE1	2:G:359:LEU:HD23	1.82	0.44
2:G:355:ASP:HB3	2:G:358:LYS:HG3	1.99	0.44
2:M:327:GLU:OE1	2:M:327:GLU:HA	2.17	0.44
1:J:218:VAL:O	1:J:221:VAL:HG12	2.18	0.44

Continued on next page...

Continued from previous page...

Atom-1	Atom-2	Interatomic distance (Å)	Clash overlap (Å)
2:N:392:HIS:HB2	2:N:415:TYR:HB3	2.00	0.44
2:E:507:HIS:N	2:E:508:PRO:CD	2.81	0.44
1:B:278:ARG:HH22	2:F:487:GLU:CD	2.21	0.44
2:H:382:PHE:CZ	2:H:386:ASN:ND2	2.86	0.44
2:M:394:GLY:HA2	2:M:412:LEU:HD22	1.98	0.44
1:K:155:ASP:OD2	1:K:155:ASP:C	2.56	0.44
1:K:238:THR:HG22	2:P:460:TYR:CE2	2.53	0.44
2:O:563:GLY:C	2:O:564:ILE:HG13	2.38	0.44
2:F:339:GLN:HE22	2:F:360:ILE:HG22	1.83	0.44
1:D:273:GLY:O	1:D:275:HIS:N	2.46	0.44
2:H:506:SER:HA	2:H:509:ARG:HG2	2.00	0.44
2:M:393:PRO:HD2	2:M:415:TYR:CG	2.53	0.44
1:K:202:ASN:OD1	1:K:203:THR:HG23	2.18	0.44
1:L:82:THR:OG1	1:L:86:VAL:HB	2.18	0.44
2:P:386:ASN:O	2:P:387:GLU:C	2.55	0.44
2:E:396:ILE:HD13	2:E:402:PHE:CZ	2.52	0.43
2:E:397:VAL:HB	2:E:398:PRO:HD2	2.00	0.43
1:B:138:PHE:C	1:B:138:PHE:CD2	2.91	0.43
1:C:128:HIS:CE1	1:C:169:VAL:HG22	2.53	0.43
2:H:327:GLU:OE1	2:H:327:GLU:HA	2.19	0.43
2:M:515:GLN:HB2	2:M:520:GLN:HG2	2.00	0.43
1:L:252:ASN:HD22	1:L:252:ASN:HA	1.65	0.43
2:P:478:LYS:O	2:P:479:ARG:HB2	2.18	0.43
1:B:289:VAL:CG2	1:B:290:ARG:N	2.81	0.43
1:B:289:VAL:HG22	1:B:290:ARG:N	2.31	0.43
2:H:363:GLU:H	2:H:363:GLU:CD	2.21	0.43
1:J:174:GLY:O	1:K:231:GLN:HG2	2.18	0.43
2:N:392:HIS:CD2	2:N:394:GLY:N	2.86	0.43
2:N:426:PRO:HB2	1:L:116:HIS:CD2	2.52	0.43
1:L:289:VAL:HG22	1:L:290:ARG:N	2.33	0.43
2:P:540:ARG:O	2:P:544:VAL:HG23	2.18	0.43
2:G:543:VAL:O	2:G:546:GLN:N	2.52	0.43
3:H:760:HDD:HBA2	3:H:760:HDD:HMA3	2.00	0.43
1:I:121:ARG:HH21	1:L:222:LYS:HZ2	1.65	0.43
2:M:548:ALA:C	2:M:550:ILE:H	2.22	0.43
2:N:369:ARG:HH11	2:N:369:ARG:HG2	1.84	0.43
1:K:280:ILE:CD1	1:K:286:ALA:HA	2.48	0.43
1:A:260:ARG:HH11	1:A:260:ARG:HB3	1.83	0.43
1:D:267[A]:ARG:NH2	2:H:330:ASP:HB2	2.33	0.43
2:H:475:PRO:HG3	2:H:483:GLU:OE2	2.19	0.43
1:I:136:GLY:HA3	2:M:375:LEU:HA	1.99	0.43

Continued on next page...

Continued from previous page...

Atom-1	Atom-2	Interatomic distance (Å)	Clash overlap (Å)
1:I:199:VAL:HG21	2:M:393:PRO:HD3	1.99	0.43
1:K:188:LYS:HZ2	1:K:195:ILE:HG21	1.82	0.43
2:O:443:PHE:CD2	2:O:460:TYR:O	2.72	0.43
2:O:516:THR:HG23	2:O:519:GLU:OE2	2.18	0.43
1:B:92:GLN:HA	1:C:213:LYS:HD3	2.00	0.43
2:H:405:ASP:OD1	2:H:405:ASP:C	2.56	0.43
2:H:507:HIS:N	2:H:508:PRO:CD	2.81	0.43
1:I:214:PHE:CD1	3:M:760:HDD:CAC	3.01	0.43
1:J:81:THR:HG22	1:J:87:ARG:HA	2.00	0.43
1:A:199:VAL:HG21	2:E:393:PRO:HD3	2.00	0.43
1:J:247:PRO:HG2	2:N:504:TYR:CE2	2.53	0.43
1:K:94:SER:HB2	1:K:103:THR:HG23	2.00	0.43
2:O:345:ASP:O	2:O:346:GLU:C	2.57	0.43
2:O:492:ASN:O	2:O:494:VAL:HG22	2.17	0.43
1:A:174:GLY:O	1:D:231:GLN:HG2	2.18	0.43
1:D:187:THR:HB	4:D:305:HOH:O	2.18	0.43
2:H:547:LEU:HD23	2:H:547:LEU:HA	1.58	0.43
1:I:131:GLY:O	2:M:319:ARG:NH2	2.51	0.43
2:M:459:ASN:ND2	1:J:219:HIS:HB3	2.34	0.43
1:J:125:ARG:CB	3:N:760:HDD:HBD1	2.45	0.43
2:N:449[A]:HIS:CE1	4:N:48:HOH:O	2.72	0.43
2:O:329:GLY:HA2	2:O:331:PHE:CE2	2.54	0.43
1:L:125:ARG:HG2	3:P:760:HDD:HBD1	2.01	0.43
1:A:180:ARG:NH1	1:A:180:ARG:HG3	2.34	0.43
2:E:353:LEU:HD23	2:E:353:LEU:HA	1.67	0.43
2:E:393:PRO:HD2	2:E:415:TYR:CG	2.54	0.43
1:B:125:ARG:CG	3:F:760:HDD:HBD1	2.47	0.43
2:G:433:ILE:O	2:G:433:ILE:HG13	2.18	0.43
2:H:393:PRO:HD2	2:H:415:TYR:CG	2.53	0.43
2:M:516:THR:O	2:M:518:PHE:N	2.52	0.43
2:M:563:GLY:C	2:M:564:ILE:HG13	2.38	0.43
2:N:545:ASP:O	2:N:548:ALA:HB3	2.19	0.43
1:K:128:HIS:NE2	3:O:760:HDD:C4A	2.82	0.43
1:K:253:VAL:O	1:K:257:MET:HG2	2.18	0.43
1:A:238:THR:HG22	2:F:460:TYR:CE2	2.54	0.43
2:E:524:VAL:O	2:E:528:SER:OG	2.29	0.43
2:E:546:GLN:O	2:E:547:LEU:C	2.56	0.43
1:B:119:HIS:ND1	2:G:421:SER:HB3	2.34	0.43
1:B:214:PHE:CD1	3:F:760:HDD:CAC	3.02	0.43
2:F:414:SER:HB2	3:F:760:HDD:HBC2	2.01	0.43
1:C:282:ALA:N	4:C:315:HOH:O	2.36	0.43

Continued on next page...

Continued from previous page...

Atom-1	Atom-2	Interatomic distance (Å)	Clash overlap (Å)
1:D:139:GLN:HA	1:D:140:PRO:HD3	1.88	0.43
2:H:410:GLY:C	2:H:412:LEU:N	2.71	0.43
2:N:393:PRO:HD2	2:N:415:TYR:CG	2.54	0.43
1:D:76:GLU:OE1	1:D:76:GLU:C	2.57	0.43
2:M:397:VAL:CG2	2:M:400:LEU:HD12	2.49	0.43
2:N:536:ARG:HA	2:N:537:PRO:HD3	1.88	0.43
1:K:205:ILE:HA	1:K:274:ILE:HG23	1.99	0.43
1:L:275:HIS:HE1	2:P:407:LEU:HB3	1.82	0.43
2:E:316:ASP:O	2:E:317:PHE:C	2.57	0.42
2:M:443:PHE:CZ	2:M:461:GLU:HB3	2.54	0.42
1:J:200:GLY:HA3	1:J:272:PHE:O	2.19	0.42
2:N:392:HIS:ND1	2:N:415:TYR:CA	2.70	0.42
1:K:151:ASP:O	1:K:153:LEU:N	2.52	0.42
2:O:459:ASN:H	2:O:459:ASN:ND2	2.15	0.42
1:L:206:PHE:CG	1:L:207:PHE:N	2.86	0.42
1:B:207:PHE:O	1:B:249:THR:HA	2.19	0.42
1:B:275:HIS:HB2	1:B:277:PHE:CE2	2.54	0.42
1:D:86:VAL:O	1:D:86:VAL:HG12	2.19	0.42
1:D:224:GLU:HB3	1:D:225:PRO:HD2	2.01	0.42
1:I:281:ASN:OD1	1:I:281:ASN:C	2.57	0.42
2:O:536:ARG:HA	2:O:537:PRO:HD3	1.89	0.42
2:P:472:GLU:H	2:P:472:GLU:HG2	1.46	0.42
1:A:155:ASP:HA	1:A:156:PRO:HD3	1.88	0.42
2:F:419:GLN:HA	2:F:419:GLN:HE21	1.83	0.42
1:C:199:VAL:HB	2:G:411:ARG:HH22	1.84	0.42
1:I:155:ASP:OD2	1:I:155:ASP:C	2.57	0.42
1:I:208:ILE:HG22	4:I:302:HOH:O	2.19	0.42
1:J:222:LYS:HZ2	1:K:121:ARG:HH21	1.68	0.42
2:N:352:ASP:C	2:N:352:ASP:OD2	2.57	0.42
2:O:547:LEU:HD23	2:O:547:LEU:HA	1.68	0.42
2:G:490:GLU:HG2	2:H:490:GLU:HG2	2.00	0.42
1:D:138:PHE:CD2	1:D:138:PHE:C	2.93	0.42
1:D:206:PHE:CD1	3:H:760:HDD:HBB1	2.54	0.42
2:H:505:TYR:C	2:H:508:PRO:HD2	2.40	0.42
1:I:186:ALA:HB2	3:M:760:HDD:HMA3	2.01	0.42
3:M:760:HDD:HBC1	3:M:760:HDD:CMC	2.41	0.42
1:B:126:ILE:H	1:B:126:ILE:HG12	1.67	0.42
1:B:174:GLY:O	1:C:231:GLN:HG2	2.20	0.42
2:G:541:GLU:H	2:G:541:GLU:HG2	1.72	0.42
1:A:76:GLU:OE1	1:A:76:GLU:C	2.58	0.42
1:A:193:GLU:OE1	2:E:479:ARG:HD3	2.20	0.42

Continued on next page...

Continued from previous page...

Atom-1	Atom-2	Interatomic distance (Å)	Clash overlap (Å)
1:D:214:PHE:CD1	3:H:760:HDD:CAC	3.03	0.42
1:K:97:ALA:O	1:K:101:GLY:HA3	2.20	0.42
2:P:536:ARG:HA	2:P:537:PRO:HD3	1.82	0.42
1:B:252:ASN:HD22	1:B:252:ASN:HA	1.63	0.42
2:F:507:HIS:N	2:F:508:PRO:CD	2.82	0.42
2:F:537:PRO:O	2:F:540:ARG:HB2	2.20	0.42
2:H:493:LYS:O	2:H:494:VAL:HG13	2.19	0.42
2:N:319:ARG:HD3	1:K:227:TRP:O	2.20	0.42
2:N:505:TYR:O	2:N:508:PRO:HD2	2.20	0.42
1:K:247:PRO:HB2	2:O:504:TYR:CD2	2.55	0.42
1:L:169:VAL:HG21	1:L:182:ILE:HB	2.02	0.42
1:L:199:VAL:HB	2:P:411:ARG:HH22	1.84	0.42
3:P:760:HDD:HMC1	3:P:760:HDD:CBC	2.49	0.42
1:B:160:THR:HG22	1:B:161:PRO:O	2.20	0.42
2:F:410:GLY:O	2:F:411:ARG:C	2.56	0.42
2:G:469:TRP:HA	2:G:470:PRO:C	2.39	0.42
1:I:149:LYS:O	1:I:149:LYS:HG3	2.20	0.42
1:L:247:PRO:O	1:L:250:LEU:HG	2.18	0.42
2:F:353:LEU:HD23	2:F:353:LEU:HA	1.79	0.42
1:C:197:ASP:HB2	2:G:392:HIS:O	2.20	0.42
2:G:515:GLN:HB2	2:G:520:GLN:HG2	2.02	0.42
2:G:547:LEU:HA	2:G:547:LEU:HD23	1.56	0.42
1:D:125:ARG:HG3	1:D:125:ARG:NH1	2.34	0.42
2:N:449[B]:HIS:HD1	2:P:449:HIS:CB	2.32	0.42
1:B:190:TYR:CD2	1:B:190:TYR:N	2.87	0.42
2:F:412:LEU:HD23	2:F:412:LEU:HA	1.64	0.42
1:C:266:TYR:CE2	2:G:318:HIS:HB3	2.55	0.42
1:C:276:THR:O	2:G:403:THR:CG2	2.68	0.42
1:B:206:PHE:CD1	2:F:407:LEU:HD21	2.55	0.41
1:B:231:GLN:O	1:B:233:GLN:HG3	2.20	0.41
2:F:486:GLN:H	2:F:486:GLN:HG2	1.55	0.41
1:D:155:ASP:HA	1:D:156:PRO:HD3	1.90	0.41
2:O:380:ASP:N	2:O:385:GLU:OE2	2.41	0.41
2:P:411:ARG:O	2:P:413:PHE:N	2.53	0.41
1:A:125:ARG:HG2	3:E:760:HDD:HBD1	2.02	0.41
1:A:148:THR:HB	1:A:279:LEU:HB3	2.01	0.41
2:E:456:ASN:HA	2:E:457:PRO:HD2	1.96	0.41
1:B:136:GLY:HA3	2:F:374:VAL:O	2.20	0.41
1:C:180:ARG:NH1	1:C:256:ALA:O	2.54	0.41
1:C:289:VAL:CG2	1:C:290:ARG:N	2.82	0.41
1:D:155:ASP:OD2	1:D:155:ASP:C	2.58	0.41

Continued on next page...

Continued from previous page...

Atom-1	Atom-2	Interatomic distance (Å)	Clash overlap (Å)
1:D:282:ALA:CB	4:D:310:HOH:O	2.68	0.41
2:H:459:ASN:HD22	2:H:459:ASN:N	2.18	0.41
1:I:184:GLY:HA2	1:I:201:ASN:HA	2.02	0.41
1:I:185:PHE:N	1:I:200:GLY:O	2.52	0.41
1:J:206:PHE:CD1	2:N:407:LEU:HD21	2.55	0.41
1:J:279:LEU:C	1:J:280:ILE:HD13	2.41	0.41
2:N:411:ARG:NE	3:N:760:HDD:CHC	2.83	0.41
2:O:331:PHE:HA	2:O:332:PRO:HD3	1.92	0.41
1:B:84:GLN:HG3	2:H:395:HIS:CD2	2.55	0.41
1:B:128:HIS:CE1	1:B:169:VAL:HG22	2.55	0.41
2:F:456:ASN:OD1	2:F:456:ASN:C	2.59	0.41
1:D:122:ILE:HB	1:D:123:PRO:CD	2.49	0.41
1:D:230:PRO:HG2	1:D:233:GLN:HB2	2.02	0.41
2:H:323:TRP:CE2	2:H:378:ASN:ND2	2.88	0.41
2:H:444:GLN:O	2:H:445:ARG:HD3	2.20	0.41
2:H:515:GLN:HB2	2:H:520:GLN:HG2	2.01	0.41
1:I:281:ASN:HD21	1:I:285:LYS:HB3	1.86	0.41
2:M:397:VAL:HG22	2:M:400:LEU:HD12	2.02	0.41
1:J:251:HIS:CE1	2:N:507:HIS:HB3	2.56	0.41
2:O:443:PHE:CE2	2:O:460:TYR:O	2.73	0.41
1:A:180:ARG:HG3	1:A:180:ARG:HH11	1.84	0.41
1:A:213:LYS:HD2	1:A:213:LYS:HA	1.74	0.41
2:E:459:ASN:HD22	2:E:459:ASN:N	2.13	0.41
2:F:444:GLN:C	2:F:445:ARG:HG2	2.40	0.41
1:D:125:ARG:CB	3:H:760:HDD:HBD1	2.49	0.41
1:I:213:LYS:HB3	1:I:213:LYS:HE3	1.72	0.41
2:M:466:ASN:O	2:M:466:ASN:ND2	2.54	0.41
1:K:138:PHE:CD2	1:K:138:PHE:C	2.94	0.41
2:O:509:ARG:CG	2:O:550:ILE:O	2.68	0.41
1:B:236:HIS:CD2	1:B:236:HIS:N	2.89	0.41
2:F:459:ASN:N	2:F:459:ASN:ND2	2.60	0.41
2:H:461:GLU:OE2	2:H:462:PRO:N	2.54	0.41
1:I:122:ILE:HB	1:I:123:PRO:HD2	2.02	0.41
2:N:351:PHE:CD1	2:N:351:PHE:C	2.94	0.41
1:K:115:THR:O	1:K:116:HIS:C	2.57	0.41
1:K:135:HIS:HB2	2:O:377:ARG:HB3	2.01	0.41
2:P:407:LEU:HD12	2:P:407:LEU:HA	1.77	0.41
2:P:508:PRO:O	2:P:511:PHE:HB3	2.20	0.41
1:A:107:ASP:OD2	1:A:107:ASP:C	2.57	0.41
2:F:529:PHE:O	2:F:532:SER:OG	2.31	0.41
2:M:331:PHE:CD2	2:M:331:PHE:N	2.85	0.41

Continued on next page...

Continued from previous page...

Atom-1	Atom-2	Interatomic distance (Å)	Clash overlap (Å)
2:M:547:LEU:HD23	2:M:547:LEU:HA	1.75	0.41
2:O:397:VAL:HG22	2:O:400:LEU:HD12	2.01	0.41
2:O:516:THR:O	2:O:519:GLU:N	2.53	0.41
1:L:178:THR:O	2:P:311:THR:HG22	2.20	0.41
2:E:359:LEU:HD21	4:E:92:HOH:O	2.20	0.41
2:E:438:CYS:HB2	2:E:439:PRO:HD2	2.01	0.41
1:D:126:ILE:H	1:D:126:ILE:HG12	1.62	0.41
1:J:169:VAL:HG21	1:J:182:ILE:HB	2.02	0.41
2:P:392:HIS:HB2	2:P:415:TYR:HB3	2.02	0.41
1:B:279:LEU:HD12	2:F:340:LEU:HD21	2.03	0.41
2:F:444:GLN:O	2:F:445:ARG:HG2	2.21	0.41
2:G:538:TYR:HA	2:G:541:GLU:CG	2.51	0.41
1:I:185:PHE:C	1:I:185:PHE:CD1	2.94	0.41
2:M:394:GLY:CA	2:M:412:LEU:HD22	2.51	0.41
2:N:541:GLU:HG2	2:N:541:GLU:H	1.52	0.41
1:K:260:ARG:O	1:K:263:PRO:HD3	2.21	0.41
1:L:246:GLN:O	1:L:249:THR:HG23	2.20	0.41
1:A:274:ILE:HD12	3:E:760:HDD:HMB1	2.02	0.41
1:A:274:ILE:CD1	3:E:760:HDD:CBB	2.98	0.41
2:E:352:ASP:HB2	2:E:500:SER:HB2	2.03	0.41
1:B:80:LEU:CD1	2:H:442:ASN:HA	2.51	0.41
1:B:294:LYS:HG3	1:B:295:PRO:N	2.35	0.41
2:G:459:ASN:HD22	2:G:460:TYR:HD2	1.67	0.41
2:G:545:ASP:O	2:G:548:ALA:HB3	2.21	0.41
2:H:353:LEU:HD23	2:H:353:LEU:HA	1.89	0.41
2:H:538:TYR:HA	2:H:541:GLU:CG	2.51	0.41
1:I:279:LEU:HG	1:I:289:VAL:CG1	2.51	0.41
2:M:392:HIS:CD2	2:M:394:GLY:H	2.38	0.41
1:J:222:LYS:HZ1	1:K:121:ARG:HH21	1.68	0.41
2:N:459:ASN:N	2:N:459:ASN:ND2	2.68	0.41
1:K:214:PHE:HB3	1:K:215:PRO:HD3	2.03	0.41
2:O:419:GLN:HE22	2:O:422:ARG:HH11	1.69	0.41
2:O:419:GLN:HE22	2:O:422:ARG:NH1	2.19	0.41
1:L:180:ARG:NH1	1:L:256:ALA:O	2.53	0.41
2:P:410:GLY:O	2:P:411:ARG:C	2.59	0.41
2:P:456:ASN:OD1	2:P:457:PRO:CD	2.67	0.41
1:A:136:GLY:HA3	2:E:374:VAL:O	2.21	0.41
1:D:188:LYS:HG3	1:D:197:ASP:OD2	2.21	0.41
1:I:116:HIS:HE1	2:O:446:ASP:O	2.04	0.41
1:I:128:HIS:O	1:I:129:ALA:C	2.58	0.41
2:M:369:ARG:HG2	2:M:369:ARG:HH11	1.86	0.41

Continued on next page...

Continued from previous page...

Atom-1	Atom-2	Interatomic distance (Å)	Clash overlap (Å)
1:J:152:PHE:HB3	1:J:191:THR:HB	2.03	0.41
2:O:498:SER:O	2:O:501:PHE:HB2	2.20	0.41
2:P:524:VAL:HG13	2:P:558:VAL:HG22	2.03	0.41
1:A:155:ASP:OD2	1:A:157:ASN:HB2	2.21	0.40
1:D:282:ALA:HB2	4:D:310:HOH:O	2.21	0.40
1:I:77:ASN:HB3	2:O:469:TRP:CH2	2.53	0.40
2:O:507:HIS:H	2:O:508:PRO:HD2	1.83	0.40
1:L:229:ILE:CG2	1:L:230:PRO:CA	2.98	0.40
1:A:77:ASN:N	1:A:77:ASN:ND2	2.67	0.40
1:A:138:PHE:CG	1:A:139:GLN:N	2.89	0.40
1:A:186:ALA:HB2	3:E:760:HDD:HMA3	2.02	0.40
1:A:222:LYS:HG3	4:D:308:HOH:O	2.20	0.40
1:D:207:PHE:O	1:D:249:THR:HA	2.21	0.40
1:J:127:VAL:HG22	3:N:760:HDD:HMD2	2.03	0.40
1:K:168:THR:HB	1:K:169:VAL:H	1.75	0.40
1:L:125:ARG:HB3	3:P:760:HDD:HBD1	2.02	0.40
1:L:181:ASP:HB3	1:L:183[A]:ARG:HH21	1.83	0.40
1:A:133:ALA:HA	1:A:164:VAL:O	2.21	0.40
1:B:200:GLY:HA3	1:B:272:PHE:O	2.22	0.40
1:I:183:ARG:HD2	1:I:183:ARG:N	2.36	0.40
2:M:386:ASN:OD1	2:M:386:ASN:C	2.60	0.40
2:M:505:TYR:O	2:M:508:PRO:HD2	2.20	0.40
1:J:83:ASN:HB3	2:P:429:HIS:CD2	2.55	0.40
2:N:412:LEU:HD23	2:N:412:LEU:HA	1.79	0.40
1:K:169:VAL:HG21	1:K:182:ILE:HB	2.03	0.40
2:O:506:SER:HA	2:O:509:ARG:HB2	2.02	0.40
2:P:323:TRP:CZ3	2:P:378:ASN:HB3	2.56	0.40
2:P:515:GLN:HB2	2:P:520:GLN:HG2	2.02	0.40
1:A:275:HIS:HB2	1:A:277:PHE:CE2	2.57	0.40
2:E:556:GLN:O	2:E:557:ALA:C	2.60	0.40
2:F:507:HIS:N	2:F:508:PRO:HD2	2.36	0.40
2:G:353:LEU:HD23	2:G:353:LEU:HA	1.80	0.40
1:D:206:PHE:CG	3:H:760:HDD:HBB1	2.54	0.40
1:I:155:ASP:HA	1:I:156:PRO:HD3	1.80	0.40
1:I:279:LEU:HD23	1:I:279:LEU:HA	1.87	0.40
1:J:115:THR:O	1:J:119:HIS:HD2	2.05	0.40
1:K:251:HIS:CE1	2:O:507:HIS:HB3	2.55	0.40
2:E:513:LEU:HD23	2:E:513:LEU:HA	1.89	0.40
1:B:143:SER:OG	1:B:145:SER:HB3	2.22	0.40
1:C:199:VAL:HB	2:G:411:ARG:NH2	2.37	0.40
1:K:266:TYR:CE2	2:O:318:HIS:HB3	2.56	0.40

All (3) symmetry-related close contacts are listed below. The label for Atom-2 includes the symmetry operator and encoded unit-cell translations to be applied.

Atom-1	Atom-2	Interatomic distance (Å)	Clash overlap (Å)
2:O:509:ARG:NH1	2:P:521:ARG:NE[2_756]	1.70	0.50
1:D:157:ASN:OD1	2:O:369:ARG:NH2[2_645]	2.16	0.04
2:O:509:ARG:NH1	2:P:521:ARG:CD[2_756]	2.19	0.01

5.3 Torsion angles [i](#)

5.3.1 Protein backbone [i](#)

In the following table, the Percentiles column shows the percent Ramachandran outliers of the chain as a percentile score with respect to all X-ray entries followed by that with respect to entries of similar resolution.

The Analysed column shows the number of residues for which the backbone conformation was analysed, and the total number of residues.

Mol	Chain	Analysed	Favoured	Allowed	Outliers	Percentiles
1	A	221/226 (98%)	208 (94%)	12 (5%)	1 (0%)	29 61
1	B	222/226 (98%)	207 (93%)	13 (6%)	2 (1%)	17 46
1	C	222/226 (98%)	214 (96%)	8 (4%)	0	100 100
1	D	222/226 (98%)	209 (94%)	11 (5%)	2 (1%)	17 46
1	I	221/226 (98%)	206 (93%)	13 (6%)	2 (1%)	17 46
1	J	221/226 (98%)	207 (94%)	14 (6%)	0	100 100
1	K	221/226 (98%)	202 (91%)	17 (8%)	2 (1%)	17 46
1	L	222/226 (98%)	206 (93%)	15 (7%)	1 (0%)	29 61
2	E	257/259 (99%)	240 (93%)	15 (6%)	2 (1%)	19 49
2	F	254/259 (98%)	238 (94%)	15 (6%)	1 (0%)	34 66
2	G	256/259 (99%)	237 (93%)	19 (7%)	0	100 100
2	H	255/259 (98%)	237 (93%)	18 (7%)	0	100 100
2	M	255/259 (98%)	230 (90%)	23 (9%)	2 (1%)	19 49
2	N	255/259 (98%)	237 (93%)	17 (7%)	1 (0%)	34 66
2	O	254/259 (98%)	228 (90%)	23 (9%)	3 (1%)	13 39
2	P	254/259 (98%)	233 (92%)	19 (8%)	2 (1%)	19 49
All	All	3812/3880 (98%)	3539 (93%)	252 (7%)	21 (1%)	29 56

All (21) Ramachandran outliers are listed below:

Mol	Chain	Res	Type
1	A	258	SER
1	I	274	ILE
1	B	77	ASN
1	B	274	ILE
1	D	145	SER
1	K	274	ILE
2	P	549	HIS
1	I	258	SER
2	N	493	LYS
2	O	432	PRO
2	P	412	LEU
1	K	248	GLU
2	O	472	GLU
2	O	486	GLN
2	M	551	ASP
1	L	248	GLU
2	E	449[A]	HIS
2	E	449[B]	HIS
2	F	432	PRO
2	M	486	GLN
1	D	274	ILE

5.3.2 Protein sidechains [i](#)

In the following table, the Percentiles column shows the percent sidechain outliers of the chain as a percentile score with respect to all X-ray entries followed by that with respect to entries of similar resolution.

The Analysed column shows the number of residues for which the sidechain conformation was analysed, and the total number of residues.

Mol	Chain	Analysed	Rotameric	Outliers	Percentiles	
1	A	189/190 (100%)	169 (89%)	20 (11%)	6	20
1	B	190/190 (100%)	169 (89%)	21 (11%)	6	19
1	C	190/190 (100%)	169 (89%)	21 (11%)	6	19
1	D	190/190 (100%)	169 (89%)	21 (11%)	6	19
1	I	189/190 (100%)	162 (86%)	27 (14%)	3	10
1	J	189/190 (100%)	166 (88%)	23 (12%)	5	15
1	K	189/190 (100%)	156 (82%)	33 (18%)	2	6

Continued on next page...

Continued from previous page...

Mol	Chain	Analysed	Rotameric	Outliers	Percentiles	
1	L	190/190 (100%)	166 (87%)	24 (13%)	4	14
2	E	229/231 (99%)	192 (84%)	37 (16%)	2	7
2	F	226/231 (98%)	199 (88%)	27 (12%)	5	16
2	G	228/231 (99%)	200 (88%)	28 (12%)	4	15
2	H	227/231 (98%)	201 (88%)	26 (12%)	5	17
2	M	227/231 (98%)	195 (86%)	32 (14%)	3	10
2	N	227/231 (98%)	194 (86%)	33 (14%)	3	9
2	O	226/231 (98%)	195 (86%)	31 (14%)	3	11
2	P	226/231 (98%)	196 (87%)	30 (13%)	4	12
All	All	3332/3368 (99%)	2898 (87%)	434 (13%)	4	13

All (434) residues with a non-rotameric sidechain are listed below:

Mol	Chain	Res	Type
1	A	76	GLU
1	A	94	SER
1	A	100	ARG
1	A	106	GLU
1	A	138	PHE
1	A	178	THR
1	A	185	PHE
1	A	188	LYS
1	A	191	THR
1	A	205	ILE
1	A	227	TRP
1	A	234	SER
1	A	237	ASP
1	A	260	ARG
1	A	262	ILE
1	A	264	ARG
1	A	267	ARG
1	A	283	GLU
1	A	285	LYS
1	A	294	LYS
2	E	310	LEU
2	E	311	THR
2	E	321	GLU
2	E	324	GLU
2	E	327	GLU

Continued on next page...

Continued from previous page...

Mol	Chain	Res	Type
2	E	330	ASP
2	E	344	GLU
2	E	368	GLN
2	E	369	ARG
2	E	370	VAL
2	E	375	LEU
2	E	416	THR
2	E	419	GLN
2	E	420	ILE
2	E	459	ASN
2	E	467	ASP
2	E	471	ARG
2	E	472	GLU
2	E	479	ARG
2	E	486[A]	GLN
2	E	486[B]	GLN
2	E	488	ARG
2	E	497	ARG
2	E	507	HIS
2	E	509	ARG
2	E	510	LEU
2	E	518	PHE
2	E	521	ARG
2	E	528	SER
2	E	533	LYS
2	E	536	ARG
2	E	539	ILE
2	E	541	GLU
2	E	545	ASP
2	E	551	ASP
2	E	552	LEU
2	E	564	ILE
1	B	77	ASN
1	B	94	SER
1	B	100	ARG
1	B	106	GLU
1	B	138	PHE
1	B	145	SER
1	B	155	ASP
1	B	158	LYS
1	B	178	THR
1	B	179	VAL

Continued on next page...

Continued from previous page...

Mol	Chain	Res	Type
1	B	183	ARG
1	B	185	PHE
1	B	205	ILE
1	B	227	TRP
1	B	234	SER
1	B	252	ASN
1	B	258	SER
1	B	260	ARG
1	B	264	ARG
1	B	283	GLU
1	B	285	LYS
2	F	310	LEU
2	F	311	THR
2	F	321	GLU
2	F	327	GLU
2	F	330	ASP
2	F	368	GLN
2	F	369	ARG
2	F	375	LEU
2	F	416	THR
2	F	433	ILE
2	F	449	HIS
2	F	459	ASN
2	F	461	GLU
2	F	467	ASP
2	F	471	ARG
2	F	472	GLU
2	F	479	ARG
2	F	483	GLU
2	F	486	GLN
2	F	488	ARG
2	F	509	ARG
2	F	518	PHE
2	F	541	GLU
2	F	545	ASP
2	F	551	ASP
2	F	552	LEU
2	F	553	THR
1	C	75	SER
1	C	76	GLU
1	C	99	SER
1	C	100	ARG

Continued on next page...

Continued from previous page...

Mol	Chain	Res	Type
1	C	127	VAL
1	C	145	SER
1	C	148	THR
1	C	155	ASP
1	C	158	LYS
1	C	185	PHE
1	C	205	ILE
1	C	227	TRP
1	C	234	SER
1	C	252	ASN
1	C	260	ARG
1	C	264	ARG
1	C	267	ARG
1	C	283	GLU
1	C	285	LYS
1	C	294[A]	LYS
1	C	294[B]	LYS
2	G	310	LEU
2	G	311	THR
2	G	321	GLU
2	G	330	ASP
2	G	358	LYS
2	G	363	GLU
2	G	369	ARG
2	G	370	VAL
2	G	375	LEU
2	G	405	ASP
2	G	416	THR
2	G	459	ASN
2	G	462	PRO
2	G	467	ASP
2	G	471	ARG
2	G	472	GLU
2	G	479	ARG
2	G	486	GLN
2	G	488	ARG
2	G	509[A]	ARG
2	G	509[B]	ARG
2	G	518	PHE
2	G	539	ILE
2	G	541	GLU
2	G	545	ASP

Continued on next page...

Continued from previous page...

Mol	Chain	Res	Type
2	G	547	LEU
2	G	551	ASP
2	G	552	LEU
1	D	75	SER
1	D	99	SER
1	D	100	ARG
1	D	106	GLU
1	D	138	PHE
1	D	142	LYS
1	D	145	SER
1	D	155	ASP
1	D	178	THR
1	D	185	PHE
1	D	191	THR
1	D	205	ILE
1	D	227	TRP
1	D	252	ASN
1	D	260	ARG
1	D	264	ARG
1	D	267[A]	ARG
1	D	267[B]	ARG
1	D	283	GLU
1	D	285	LYS
1	D	294	LYS
2	H	310	LEU
2	H	311	THR
2	H	321	GLU
2	H	327	GLU
2	H	330	ASP
2	H	363	GLU
2	H	368	GLN
2	H	369	ARG
2	H	370	VAL
2	H	375	LEU
2	H	405	ASP
2	H	416	THR
2	H	459	ASN
2	H	461	GLU
2	H	467	ASP
2	H	471	ARG
2	H	472	GLU
2	H	483	GLU

Continued on next page...

Continued from previous page...

Mol	Chain	Res	Type
2	H	486	GLN
2	H	488	ARG
2	H	518	PHE
2	H	536	ARG
2	H	539	ILE
2	H	541	GLU
2	H	545	ASP
2	H	552	LEU
1	I	75	SER
1	I	76	GLU
1	I	94	SER
1	I	100	ARG
1	I	106	GLU
1	I	138	PHE
1	I	145	SER
1	I	148	THR
1	I	149	LYS
1	I	151	ASP
1	I	158	LYS
1	I	178	THR
1	I	183	ARG
1	I	185	PHE
1	I	188	LYS
1	I	191	THR
1	I	205	ILE
1	I	227	TRP
1	I	234	SER
1	I	252	ASN
1	I	254	MET
1	I	260	ARG
1	I	262	ILE
1	I	264	ARG
1	I	267	ARG
1	I	283	GLU
1	I	285	LYS
2	M	310	LEU
2	M	311	THR
2	M	321	GLU
2	M	327	GLU
2	M	330	ASP
2	M	368	GLN
2	M	369	ARG

Continued on next page...

Continued from previous page...

Mol	Chain	Res	Type
2	M	370	VAL
2	M	375	LEU
2	M	402	PHE
2	M	416	THR
2	M	422	ARG
2	M	433	ILE
2	M	434	ASN
2	M	451	MET
2	M	456	ASN
2	M	459	ASN
2	M	461	GLU
2	M	467	ASP
2	M	471	ARG
2	M	472	GLU
2	M	483	GLU
2	M	486	GLN
2	M	488	ARG
2	M	509	ARG
2	M	518	PHE
2	M	521	ARG
2	M	536	ARG
2	M	539	ILE
2	M	541	GLU
2	M	545	ASP
2	M	552	LEU
1	J	75	SER
1	J	77	ASN
1	J	96	ARG
1	J	99	SER
1	J	100	ARG
1	J	138	PHE
1	J	148	THR
1	J	178	THR
1	J	183	ARG
1	J	185	PHE
1	J	191	THR
1	J	205	ILE
1	J	227	TRP
1	J	234	SER
1	J	252	ASN
1	J	258	SER
1	J	260	ARG

Continued on next page...

Continued from previous page...

Mol	Chain	Res	Type
1	J	264	ARG
1	J	265	SER
1	J	267	ARG
1	J	283	GLU
1	J	285	LYS
1	J	294	LYS
2	N	310	LEU
2	N	311	THR
2	N	321	GLU
2	N	327	GLU
2	N	330	ASP
2	N	368	GLN
2	N	369	ARG
2	N	370	VAL
2	N	375	LEU
2	N	414	SER
2	N	416	THR
2	N	449[A]	HIS
2	N	449[B]	HIS
2	N	459	ASN
2	N	467	ASP
2	N	471	ARG
2	N	472	GLU
2	N	479	ARG
2	N	484	SER
2	N	486	GLN
2	N	488	ARG
2	N	509	ARG
2	N	510	LEU
2	N	518	PHE
2	N	521	ARG
2	N	532	SER
2	N	533	LYS
2	N	536	ARG
2	N	539	ILE
2	N	541	GLU
2	N	545	ASP
2	N	551	ASP
2	N	552	LEU
1	K	75	SER
1	K	94	SER
1	K	96	ARG

Continued on next page...

Continued from previous page...

Mol	Chain	Res	Type
1	K	99	SER
1	K	100	ARG
1	K	106	GLU
1	K	113	LYS
1	K	127	VAL
1	K	138	PHE
1	K	148	THR
1	K	149	LYS
1	K	151	ASP
1	K	155	ASP
1	K	158	LYS
1	K	168	THR
1	K	178	THR
1	K	183	ARG
1	K	185	PHE
1	K	188	LYS
1	K	191	THR
1	K	195	ILE
1	K	205	ILE
1	K	221	VAL
1	K	227	TRP
1	K	234	SER
1	K	252	ASN
1	K	258	SER
1	K	260	ARG
1	K	264	ARG
1	K	265	SER
1	K	283	GLU
1	K	285	LYS
1	K	294	LYS
2	O	310	LEU
2	O	311	THR
2	O	321	GLU
2	O	324	GLU
2	O	327	GLU
2	O	330	ASP
2	O	363	GLU
2	O	369	ARG
2	O	370	VAL
2	O	405	ASP
2	O	416	THR
2	O	434	ASN

Continued on next page...

Continued from previous page...

Mol	Chain	Res	Type
2	O	435	ARG
2	O	446	ASP
2	O	449	HIS
2	O	459	ASN
2	O	467	ASP
2	O	471	ARG
2	O	472	GLU
2	O	479	ARG
2	O	483	GLU
2	O	486	GLN
2	O	488	ARG
2	O	509	ARG
2	O	510	LEU
2	O	518	PHE
2	O	521	ARG
2	O	536	ARG
2	O	542	ARG
2	O	545	ASP
2	O	552	LEU
1	L	75	SER
1	L	76	GLU
1	L	77	ASN
1	L	94	SER
1	L	99	SER
1	L	106	GLU
1	L	127	VAL
1	L	138	PHE
1	L	145	SER
1	L	158	LYS
1	L	178	THR
1	L	179	VAL
1	L	183[A]	ARG
1	L	183[B]	ARG
1	L	185	PHE
1	L	205	ILE
1	L	227	TRP
1	L	252	ASN
1	L	260	ARG
1	L	262	ILE
1	L	264	ARG
1	L	267	ARG
1	L	283	GLU

Continued on next page...

Continued from previous page...

Mol	Chain	Res	Type
1	L	285	LYS
2	P	310	LEU
2	P	311	THR
2	P	321	GLU
2	P	324	GLU
2	P	330	ASP
2	P	363	GLU
2	P	368	GLN
2	P	369	ARG
2	P	370	VAL
2	P	375	LEU
2	P	416	THR
2	P	459	ASN
2	P	461	GLU
2	P	467	ASP
2	P	471	ARG
2	P	472	GLU
2	P	479	ARG
2	P	486	GLN
2	P	488	ARG
2	P	507	HIS
2	P	509	ARG
2	P	518	PHE
2	P	521	ARG
2	P	532	SER
2	P	533	LYS
2	P	539	ILE
2	P	541	GLU
2	P	545	ASP
2	P	552	LEU
2	P	564	ILE

Sometimes sidechains can be flipped to improve hydrogen bonding and reduce clashes. All (51) such sidechains are listed below:

Mol	Chain	Res	Type
1	A	77	ASN
1	A	252	ASN
2	E	419	GLN
2	E	459	ASN
2	E	507	HIS
2	E	556	GLN
1	B	77	ASN

Continued on next page...

Continued from previous page...

Mol	Chain	Res	Type
1	B	252	ASN
2	F	419	GLN
2	F	449	HIS
2	F	459	ASN
1	C	77	ASN
1	C	233	GLN
1	C	252	ASN
2	G	419	GLN
2	G	459	ASN
2	G	507	HIS
1	D	77	ASN
1	D	128	HIS
1	D	252	ASN
2	H	419	GLN
2	H	429	HIS
2	H	459	ASN
2	H	507	HIS
2	H	556	GLN
1	I	77	ASN
1	I	128	HIS
1	I	252	ASN
2	M	419	GLN
2	M	449	HIS
2	M	456	ASN
2	M	459	ASN
2	M	466	ASN
2	M	556	GLN
1	J	77	ASN
1	J	252	ASN
2	N	419	GLN
2	N	459	ASN
2	N	507	HIS
2	N	556	GLN
1	K	77	ASN
1	K	201	ASN
1	K	252	ASN
2	O	419	GLN
2	O	449	HIS
2	O	459	ASN
1	L	77	ASN
1	L	252	ASN
2	P	419	GLN

Continued on next page...

Continued from previous page...

Mol	Chain	Res	Type
2	P	459	ASN
2	P	556	GLN

5.3.3 RNA [i](#)

There are no RNA molecules in this entry.

5.4 Non-standard residues in protein, DNA, RNA chains [i](#)

There are no non-standard protein/DNA/RNA residues in this entry.

5.5 Carbohydrates [i](#)

There are no monosaccharides in this entry.

5.6 Ligand geometry [i](#)

8 ligands are modelled in this entry.

In the following table, the Counts columns list the number of bonds (or angles) for which Mogul statistics could be retrieved, the number of bonds (or angles) that are observed in the model and the number of bonds (or angles) that are defined in the Chemical Component Dictionary. The Link column lists molecule types, if any, to which the group is linked. The Z score for a bond length (or angle) is the number of standard deviations the observed value is removed from the expected value. A bond length (or angle) with $|Z| > 2$ is considered an outlier worth inspection. RMSZ is the root-mean-square of all Z scores of the bond lengths (or angles).

Mol	Type	Chain	Res	Link	Bond lengths			Bond angles		
					Counts	RMSZ	# Z > 2	Counts	RMSZ	# Z > 2
3	HDD	G	760	2	41,52,52	3.00	12 (29%)	31,89,89	4.13	16 (51%)
3	HDD	N	760	2	41,52,52	3.08	12 (29%)	31,89,89	4.37	16 (51%)
3	HDD	M	760	2	41,52,52	3.06	15 (36%)	31,89,89	4.31	14 (45%)
3	HDD	E	760	2	41,52,52	3.25	14 (34%)	31,89,89	4.87	18 (58%)
3	HDD	O	760	2	41,52,52	2.95	17 (41%)	31,89,89	4.31	13 (41%)
3	HDD	H	760	2	41,52,52	3.03	14 (34%)	31,89,89	4.33	15 (48%)
3	HDD	P	760	2	41,52,52	3.20	16 (39%)	31,89,89	5.06	18 (58%)
3	HDD	F	760	2	41,52,52	2.78	11 (26%)	31,89,89	4.37	15 (48%)

In the following table, the Chirals column lists the number of chiral outliers, the number of chiral

centers analysed, the number of these observed in the model and the number defined in the Chemical Component Dictionary. Similar counts are reported in the Torsion and Rings columns. '2' means no outliers of that kind were identified.

Mol	Type	Chain	Res	Link	Chirals	Torsions	Rings
3	HDD	G	760	2	-	2/5/89/89	0/1/9/9
3	HDD	N	760	2	-	2/5/89/89	0/1/9/9
3	HDD	M	760	2	-	2/5/89/89	0/1/9/9
3	HDD	E	760	2	-	2/5/89/89	0/1/9/9
3	HDD	O	760	2	-	4/5/89/89	0/1/9/9
3	HDD	H	760	2	-	2/5/89/89	0/1/9/9
3	HDD	P	760	2	-	4/5/89/89	0/1/9/9
3	HDD	F	760	2	-	3/5/89/89	0/1/9/9

All (111) bond length outliers are listed below:

Mol	Chain	Res	Type	Atoms	Z	Observed(Å)	Ideal(Å)
3	P	760	HDD	CHD-C1D	-9.74	1.20	1.36
3	E	760	HDD	CHD-C1D	-9.19	1.21	1.36
3	O	760	HDD	CHD-C1D	-8.90	1.21	1.36
3	M	760	HDD	CHD-C1D	-8.87	1.21	1.36
3	G	760	HDD	CHD-C1D	-8.68	1.22	1.36
3	P	760	HDD	CHA-C4D	-8.55	1.22	1.36
3	H	760	HDD	CHA-C4D	-8.20	1.23	1.36
3	N	760	HDD	CHD-C1D	-8.14	1.23	1.36
3	M	760	HDD	CHA-C4D	-8.11	1.23	1.36
3	E	760	HDD	CHA-C4D	-8.10	1.23	1.36
3	N	760	HDD	CHA-C4D	-7.90	1.23	1.36
3	H	760	HDD	C3C-C2C	7.89	1.51	1.40
3	G	760	HDD	CHA-C4D	-7.88	1.23	1.36
3	F	760	HDD	CHA-C4D	-7.79	1.23	1.36
3	F	760	HDD	CHD-C1D	-7.74	1.23	1.36
3	O	760	HDD	CHA-C4D	-7.66	1.23	1.36
3	M	760	HDD	C3C-C2C	7.63	1.51	1.40
3	H	760	HDD	CHD-C1D	-7.63	1.23	1.36
3	N	760	HDD	C3C-C2C	7.45	1.50	1.40
3	P	760	HDD	O1D-CGD	7.12	1.47	1.35
3	G	760	HDD	C3C-C2C	7.05	1.50	1.40
3	E	760	HDD	C3B-C2B	6.82	1.49	1.40
3	E	760	HDD	C3C-C2C	6.72	1.49	1.40
3	P	760	HDD	C3C-C2C	6.51	1.49	1.40
3	H	760	HDD	C3B-C2B	6.46	1.49	1.40
3	G	760	HDD	C3B-C2B	6.41	1.49	1.40

Continued on next page...

Continued from previous page...

Mol	Chain	Res	Type	Atoms	Z	Observed(Å)	Ideal(Å)
3	N	760	HDD	C3B-C2B	6.39	1.49	1.40
3	O	760	HDD	O1D-CGD	6.33	1.46	1.35
3	H	760	HDD	O1D-CGD	6.29	1.46	1.35
3	F	760	HDD	O1D-CGD	6.28	1.46	1.35
3	M	760	HDD	O1D-CGD	6.25	1.45	1.35
3	E	760	HDD	O1D-CGD	5.84	1.45	1.35
3	M	760	HDD	C3B-C2B	5.82	1.48	1.40
3	O	760	HDD	C3C-C2C	5.79	1.48	1.40
3	F	760	HDD	C3C-C2C	5.74	1.48	1.40
3	F	760	HDD	C3B-C2B	5.62	1.48	1.40
3	N	760	HDD	O1D-CGD	5.55	1.44	1.35
3	G	760	HDD	O1D-CGD	5.36	1.44	1.35
3	P	760	HDD	C3B-C2B	5.30	1.47	1.40
3	O	760	HDD	C3B-C2B	5.26	1.47	1.40
3	P	760	HDD	C2A-C3A	5.22	1.53	1.37
3	E	760	HDD	C1D-ND	-5.15	1.29	1.37
3	E	760	HDD	C4C-NC	-4.75	1.26	1.36
3	N	760	HDD	C1C-CHC	-4.59	1.28	1.41
3	E	760	HDD	C4C-CHD	-4.46	1.28	1.41
3	N	760	HDD	C4C-NC	-4.35	1.27	1.36
3	G	760	HDD	C4C-CHD	-4.33	1.28	1.41
3	O	760	HDD	C4C-CHD	-4.27	1.29	1.41
3	G	760	HDD	C2A-C3A	4.25	1.50	1.37
3	M	760	HDD	C4C-CHD	-4.07	1.29	1.41
3	P	760	HDD	C4C-CHD	-4.02	1.29	1.41
3	N	760	HDD	C4C-CHD	-3.96	1.30	1.41
3	E	760	HDD	C1A-CHA	-3.86	1.30	1.41
3	E	760	HDD	C1C-CHC	-3.78	1.30	1.41
3	H	760	HDD	C1C-CHC	-3.75	1.30	1.41
3	O	760	HDD	C2A-C3A	3.75	1.48	1.37
3	F	760	HDD	C1C-CHC	-3.72	1.30	1.41
3	H	760	HDD	C2A-C3A	3.62	1.48	1.37
3	N	760	HDD	C1A-CHA	-3.57	1.31	1.41
3	O	760	HDD	C1C-CHC	-3.55	1.31	1.41
3	M	760	HDD	C1C-CHC	-3.51	1.31	1.41
3	F	760	HDD	C2A-C3A	3.51	1.48	1.37
3	P	760	HDD	C1A-CHA	-3.51	1.31	1.41
3	H	760	HDD	C1A-CHA	-3.51	1.31	1.41
3	G	760	HDD	C1C-CHC	-3.50	1.31	1.41
3	N	760	HDD	C2A-C3A	3.50	1.48	1.37
3	M	760	HDD	C1A-CHA	-3.46	1.31	1.41
3	H	760	HDD	C4C-CHD	-3.44	1.31	1.41

Continued on next page...

Continued from previous page...

Mol	Chain	Res	Type	Atoms	Z	Observed(Å)	Ideal(Å)
3	M	760	HDD	C2A-C3A	3.43	1.47	1.37
3	N	760	HDD	C1D-ND	-3.41	1.31	1.37
3	P	760	HDD	C1C-CHC	-3.34	1.31	1.41
3	F	760	HDD	C1A-CHA	-3.32	1.31	1.41
3	G	760	HDD	C1A-CHA	-3.31	1.31	1.41
3	P	760	HDD	C1D-ND	-3.22	1.32	1.37
3	F	760	HDD	C4C-CHD	-3.14	1.32	1.41
3	O	760	HDD	C1A-CHA	-2.97	1.32	1.41
3	O	760	HDD	C4D-ND	-2.95	1.32	1.37
3	O	760	HDD	C4C-NC	-2.90	1.30	1.36
3	M	760	HDD	C4D-ND	-2.90	1.32	1.37
3	P	760	HDD	CAA-C2A	-2.79	1.47	1.52
3	E	760	HDD	C1A-NA	-2.78	1.30	1.36
3	O	760	HDD	C1D-ND	-2.75	1.33	1.37
3	P	760	HDD	C4C-NC	-2.73	1.30	1.36
3	E	760	HDD	C2A-C3A	2.69	1.45	1.37
3	H	760	HDD	C1C-NC	-2.57	1.30	1.36
3	G	760	HDD	O1D-C3D	-2.56	1.42	1.46
3	H	760	HDD	C4C-NC	-2.55	1.30	1.36
3	M	760	HDD	C4C-NC	-2.55	1.30	1.36
3	P	760	HDD	O1A-CGA	2.50	1.30	1.22
3	H	760	HDD	CAA-C2A	-2.41	1.48	1.52
3	G	760	HDD	C4C-NC	-2.40	1.31	1.36
3	P	760	HDD	C1C-NC	-2.32	1.31	1.36
3	N	760	HDD	C1C-NC	-2.31	1.31	1.36
3	E	760	HDD	C4D-ND	-2.25	1.33	1.37
3	P	760	HDD	C4A-NA	-2.23	1.31	1.36
3	O	760	HDD	C1C-NC	-2.23	1.31	1.36
3	P	760	HDD	C1A-NA	-2.22	1.31	1.36
3	H	760	HDD	FE-NA	2.20	2.14	1.96
3	O	760	HDD	C4A-CHB	2.18	1.47	1.41
3	M	760	HDD	FE-NB	2.14	2.14	1.96
3	M	760	HDD	C1A-NA	-2.11	1.31	1.36
3	E	760	HDD	C4A-NA	-2.10	1.31	1.36
3	F	760	HDD	C4D-ND	-2.06	1.34	1.37
3	H	760	HDD	C1D-ND	-2.06	1.34	1.37
3	F	760	HDD	C1C-NC	-2.06	1.31	1.36
3	O	760	HDD	CBA-CGA	2.05	1.55	1.50
3	M	760	HDD	C4A-NA	-2.04	1.32	1.36
3	G	760	HDD	C4D-ND	-2.02	1.34	1.37
3	M	760	HDD	C1D-ND	-2.02	1.34	1.37
3	O	760	HDD	FE-NB	2.02	2.13	1.96

Continued on next page...

Continued from previous page...

Mol	Chain	Res	Type	Atoms	Z	Observed(Å)	Ideal(Å)
3	O	760	HDD	FE-NA	2.01	2.13	1.96

All (125) bond angle outliers are listed below:

Mol	Chain	Res	Type	Atoms	Z	Observed(°)	Ideal(°)
3	O	760	HDD	C1A-CHA-C4D	13.97	157.77	130.12
3	E	760	HDD	C4C-CHD-C1D	13.89	157.61	130.12
3	E	760	HDD	C1A-CHA-C4D	13.43	156.71	130.12
3	M	760	HDD	C1A-CHA-C4D	13.35	156.55	130.12
3	N	760	HDD	C4C-CHD-C1D	13.24	156.33	130.12
3	H	760	HDD	C1A-CHA-C4D	13.22	156.30	130.12
3	G	760	HDD	C1A-CHA-C4D	12.94	155.73	130.12
3	F	760	HDD	C1A-CHA-C4D	12.80	155.46	130.12
3	P	760	HDD	C4C-CHD-C1D	12.58	155.03	130.12
3	P	760	HDD	C1A-CHA-C4D	12.19	154.25	130.12
3	O	760	HDD	C4C-CHD-C1D	11.87	153.61	130.12
3	N	760	HDD	C1A-CHA-C4D	11.61	153.10	130.12
3	M	760	HDD	C4C-CHD-C1D	11.34	152.57	130.12
3	F	760	HDD	C4C-CHD-C1D	10.90	151.69	130.12
3	H	760	HDD	C4C-CHD-C1D	10.08	150.06	130.12
3	G	760	HDD	C4C-CHD-C1D	9.56	149.04	130.12
3	P	760	HDD	CHA-C4D-ND	-9.56	110.19	124.20
3	E	760	HDD	CHA-C4D-ND	-8.81	111.30	124.20
3	P	760	HDD	CHD-C1D-ND	-8.57	111.64	124.20
3	O	760	HDD	CHA-C4D-ND	-8.11	112.32	124.20
3	M	760	HDD	CHA-C4D-ND	-8.00	112.47	124.20
3	H	760	HDD	CHA-C4D-ND	-7.36	113.42	124.20
3	F	760	HDD	CHA-C4D-ND	-7.34	113.45	124.20
3	G	760	HDD	CHA-C4D-ND	-7.22	113.62	124.20
3	P	760	HDD	O1D-CGD-O2D	6.82	126.89	120.80
3	H	760	HDD	C4A-C3A-C2A	-6.74	102.31	107.00
3	F	760	HDD	CBA-CAA-C2A	6.74	124.12	112.62
3	N	760	HDD	CHA-C4D-ND	-6.62	114.50	124.20
3	M	760	HDD	CHD-C1D-ND	-6.60	114.53	124.20
3	N	760	HDD	CHD-C1D-ND	-6.57	114.58	124.20
3	P	760	HDD	C4A-C3A-C2A	-6.48	102.49	107.00
3	E	760	HDD	CHD-C1D-ND	-6.46	114.74	124.20
3	P	760	HDD	CMA-C3A-C2A	6.44	137.08	124.94
3	O	760	HDD	CHD-C1D-ND	-6.31	114.95	124.20
3	M	760	HDD	O1D-CGD-O2D	6.16	126.30	120.80
3	G	760	HDD	OND-C2D-C1D	-6.12	99.51	111.92
3	F	760	HDD	CHD-C1D-ND	-6.12	115.23	124.20

Continued on next page...

Continued from previous page...

Mol	Chain	Res	Type	Atoms	Z	Observed(°)	Ideal(°)
3	H	760	HDD	CHD-C1D-ND	-6.07	115.30	124.20
3	E	760	HDD	O1D-CGD-O2D	5.85	126.02	120.80
3	G	760	HDD	C4A-C3A-C2A	-5.82	102.95	107.00
3	O	760	HDD	O1D-CGD-O2D	5.73	125.92	120.80
3	P	760	HDD	OND-C2D-CMD	-5.61	99.26	109.59
3	N	760	HDD	CAA-CBA-CGA	-5.60	98.06	113.76
3	G	760	HDD	CHD-C1D-ND	-5.37	116.34	124.20
3	H	760	HDD	O1D-CGD-O2D	5.34	125.57	120.80
3	E	760	HDD	C2B-C3B-C4B	-5.24	103.24	106.90
3	F	760	HDD	C2B-C3B-C4B	-5.24	103.24	106.90
3	P	760	HDD	CMA-C3A-C4A	-5.23	120.42	128.46
3	F	760	HDD	CAA-CBA-CGA	-5.17	99.26	113.76
3	N	760	HDD	C4A-C3A-C2A	-5.15	103.41	107.00
3	H	760	HDD	C2D-C1D-CHD	5.05	132.62	124.28
3	E	760	HDD	O1D-C3D-C4D	-4.99	98.11	108.25
3	H	760	HDD	CBA-CAA-C2A	-4.83	104.39	112.62
3	P	760	HDD	CMC-C2C-C1C	4.79	135.83	128.46
3	M	760	HDD	C4A-C3A-C2A	-4.72	103.72	107.00
3	P	760	HDD	CBA-CAA-C2A	-4.71	104.58	112.62
3	P	760	HDD	C2D-C1D-CHD	4.69	132.03	124.28
3	E	760	HDD	OND-C2D-C3D	4.68	122.08	110.45
3	N	760	HDD	C2D-C1D-CHD	4.64	131.94	124.28
3	M	760	HDD	C2B-C3B-C4B	-4.63	103.67	106.90
3	H	760	HDD	CMC-C2C-C3C	4.58	133.25	124.68
3	E	760	HDD	C2D-C1D-CHD	4.55	131.79	124.28
3	E	760	HDD	C4A-C3A-C2A	-4.37	103.95	107.00
3	F	760	HDD	O1D-CGD-O2D	4.32	124.66	120.80
3	F	760	HDD	C4A-C3A-C2A	-4.21	104.06	107.00
3	F	760	HDD	C2D-C1D-CHD	4.19	131.19	124.28
3	G	760	HDD	C2B-C3B-C4B	-4.18	103.98	106.90
3	N	760	HDD	C2B-C3B-C4B	-4.17	103.99	106.90
3	O	760	HDD	C4A-C3A-C2A	-4.03	104.19	107.00
3	M	760	HDD	C2D-C1D-CHD	4.00	130.88	124.28
3	H	760	HDD	CAA-CBA-CGA	-3.99	102.57	113.76
3	N	760	HDD	O1D-CGD-O2D	3.93	124.31	120.80
3	N	760	HDD	CMC-C2C-C3C	3.85	131.88	124.68
3	O	760	HDD	OND-C2D-C1D	-3.83	104.15	111.92
3	G	760	HDD	C2D-C1D-CHD	3.80	130.55	124.28
3	E	760	HDD	OND-C2D-C1D	-3.76	104.29	111.92
3	E	760	HDD	CAA-CBA-CGA	-3.75	103.24	113.76
3	O	760	HDD	CMC-C2C-C1C	3.72	134.19	128.46
3	E	760	HDD	C3C-C4C-NC	3.68	113.97	109.21

Continued on next page...

Continued from previous page...

Mol	Chain	Res	Type	Atoms	Z	Observed(°)	Ideal(°)
3	F	760	HDD	CMB-C2B-C3B	3.65	131.50	124.68
3	F	760	HDD	OND-C2D-C1D	-3.59	104.63	111.92
3	O	760	HDD	C2D-C1D-CHD	3.58	130.19	124.28
3	G	760	HDD	CMA-C3A-C2A	3.57	131.68	124.94
3	P	760	HDD	CAA-CBA-CGA	-3.36	104.35	113.76
3	N	760	HDD	O1D-C3D-C4D	-3.22	101.72	108.25
3	G	760	HDD	CMD-C2D-C1D	3.17	118.27	112.63
3	E	760	HDD	C3D-C4D-CHA	3.15	133.70	124.34
3	O	760	HDD	C3D-C4D-CHA	3.11	133.58	124.34
3	O	760	HDD	C3C-C4C-NC	3.10	113.22	109.21
3	G	760	HDD	CMB-C2B-C3B	3.08	130.44	124.68
3	M	760	HDD	C3D-C4D-CHA	3.08	133.47	124.34
3	E	760	HDD	CMD-C2D-C1D	-2.94	107.41	112.63
3	H	760	HDD	CMB-C2B-C3B	2.93	130.15	124.68
3	N	760	HDD	C3D-C4D-CHA	2.88	132.89	124.34
3	M	760	HDD	O1D-C3D-C4D	2.88	114.10	108.25
3	G	760	HDD	C3D-C4D-CHA	2.86	132.84	124.34
3	G	760	HDD	O1D-CGD-O2D	2.86	123.35	120.80
3	P	760	HDD	C3D-C4D-CHA	2.83	132.73	124.34
3	P	760	HDD	C3C-C4C-NC	2.79	112.82	109.21
3	N	760	HDD	CMB-C2B-C3B	2.79	129.90	124.68
3	P	760	HDD	CMD-C2D-C1D	2.78	117.57	112.63
3	F	760	HDD	CMC-C2C-C1C	2.74	132.68	128.46
3	F	760	HDD	C3D-C4D-CHA	2.70	132.35	124.34
3	N	760	HDD	CMA-C3A-C2A	2.68	129.99	124.94
3	H	760	HDD	C2B-C3B-C4B	-2.62	105.06	106.90
3	E	760	HDD	CMC-C2C-C1C	2.61	132.48	128.46
3	H	760	HDD	OND-C2D-C3D	-2.46	104.33	110.45
3	M	760	HDD	CMA-C3A-C2A	2.45	129.56	124.94
3	P	760	HDD	O2A-CGA-O1A	2.41	129.30	123.30
3	M	760	HDD	O1A-CGA-CBA	-2.39	115.39	123.08
3	P	760	HDD	O1A-CGA-CBA	-2.38	115.42	123.08
3	O	760	HDD	C2B-C3B-C4B	-2.38	105.23	106.90
3	G	760	HDD	CAA-CBA-CGA	-2.38	107.09	113.76
3	N	760	HDD	CMD-C2D-C1D	-2.35	108.44	112.63
3	E	760	HDD	OND-C2D-CMD	2.30	113.83	109.59
3	H	760	HDD	C3D-C4D-CHA	2.27	131.07	124.34
3	M	760	HDD	C3C-C4C-NC	2.20	112.06	109.21
3	O	760	HDD	O2A-CGA-CBA	2.17	120.99	114.03
3	H	760	HDD	O1A-CGA-CBA	-2.15	116.16	123.08
3	M	760	HDD	CAA-CBA-CGA	-2.14	107.77	113.76
3	G	760	HDD	CMC-C2C-C3C	2.12	128.65	124.68

Continued on next page...

Continued from previous page...

Mol	Chain	Res	Type	Atoms	Z	Observed(°)	Ideal(°)
3	E	760	HDD	CMC-C2C-C3C	2.11	128.63	124.68
3	F	760	HDD	O1A-CGA-CBA	-2.11	116.31	123.08
3	N	760	HDD	O1A-CGA-CBA	-2.03	116.57	123.08
3	G	760	HDD	CMA-C3A-C4A	-2.01	125.37	128.46

There are no chirality outliers.

All (21) torsion outliers are listed below:

Mol	Chain	Res	Type	Atoms
3	O	760	HDD	C1A-C2A-CAA-CBA
3	O	760	HDD	C3A-C2A-CAA-CBA
3	P	760	HDD	C1A-C2A-CAA-CBA
3	P	760	HDD	C3A-C2A-CAA-CBA
3	F	760	HDD	C2A-CAA-CBA-CGA
3	O	760	HDD	CAA-CBA-CGA-O2A
3	F	760	HDD	CAA-CBA-CGA-O1A
3	H	760	HDD	CAA-CBA-CGA-O2A
3	P	760	HDD	CAA-CBA-CGA-O1A
3	H	760	HDD	CAA-CBA-CGA-O1A
3	O	760	HDD	CAA-CBA-CGA-O1A
3	N	760	HDD	CAA-CBA-CGA-O2A
3	P	760	HDD	CAA-CBA-CGA-O2A
3	G	760	HDD	CAA-CBA-CGA-O1A
3	G	760	HDD	CAA-CBA-CGA-O2A
3	E	760	HDD	CAA-CBA-CGA-O1A
3	E	760	HDD	CAA-CBA-CGA-O2A
3	M	760	HDD	CAA-CBA-CGA-O2A
3	M	760	HDD	CAA-CBA-CGA-O1A
3	F	760	HDD	CAA-CBA-CGA-O2A
3	N	760	HDD	CAA-CBA-CGA-O1A

There are no ring outliers.

8 monomers are involved in 125 short contacts:

Mol	Chain	Res	Type	Clashes	Symm-Clashes
3	G	760	HDD	9	0
3	N	760	HDD	12	0
3	M	760	HDD	20	0
3	E	760	HDD	14	0
3	O	760	HDD	19	0
3	H	760	HDD	15	0

Continued on next page...

Continued from previous page...

Mol	Chain	Res	Type	Clashes	Symm-Clashes
3	P	760	HDD	11	0
3	F	760	HDD	25	0

The following is a two-dimensional graphical depiction of Mogul quality analysis of bond lengths, bond angles, torsion angles, and ring geometry for all instances of the Ligand of Interest. In addition, ligands with molecular weight > 250 and outliers as shown on the validation Tables will also be included. For torsion angles, if less than 5% of the Mogul distribution of torsion angles is within 10 degrees of the torsion angle in question, then that torsion angle is considered an outlier. Any bond that is central to one or more torsion angles identified as an outlier by Mogul will be highlighted in the graph. For rings, the root-mean-square deviation (RMSD) between the ring in question and similar rings identified by Mogul is calculated over all ring torsion angles. If the average RMSD is greater than 60 degrees and the minimal RMSD between the ring in question and any Mogul-identified rings is also greater than 60 degrees, then that ring is considered an outlier. The outliers are highlighted in purple. The color gray indicates Mogul did not find sufficient equivalents in the CSD to analyse the geometry.

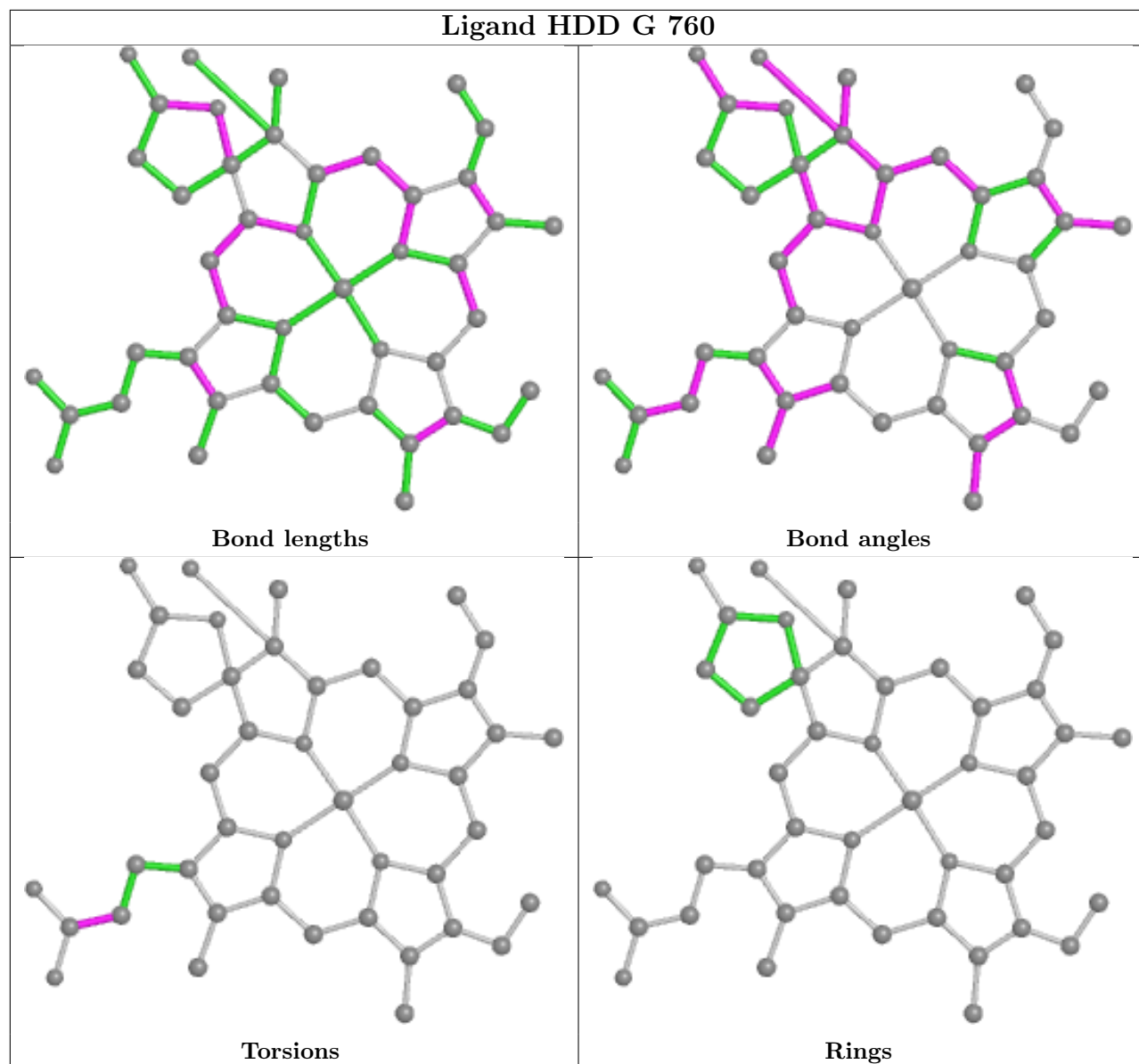

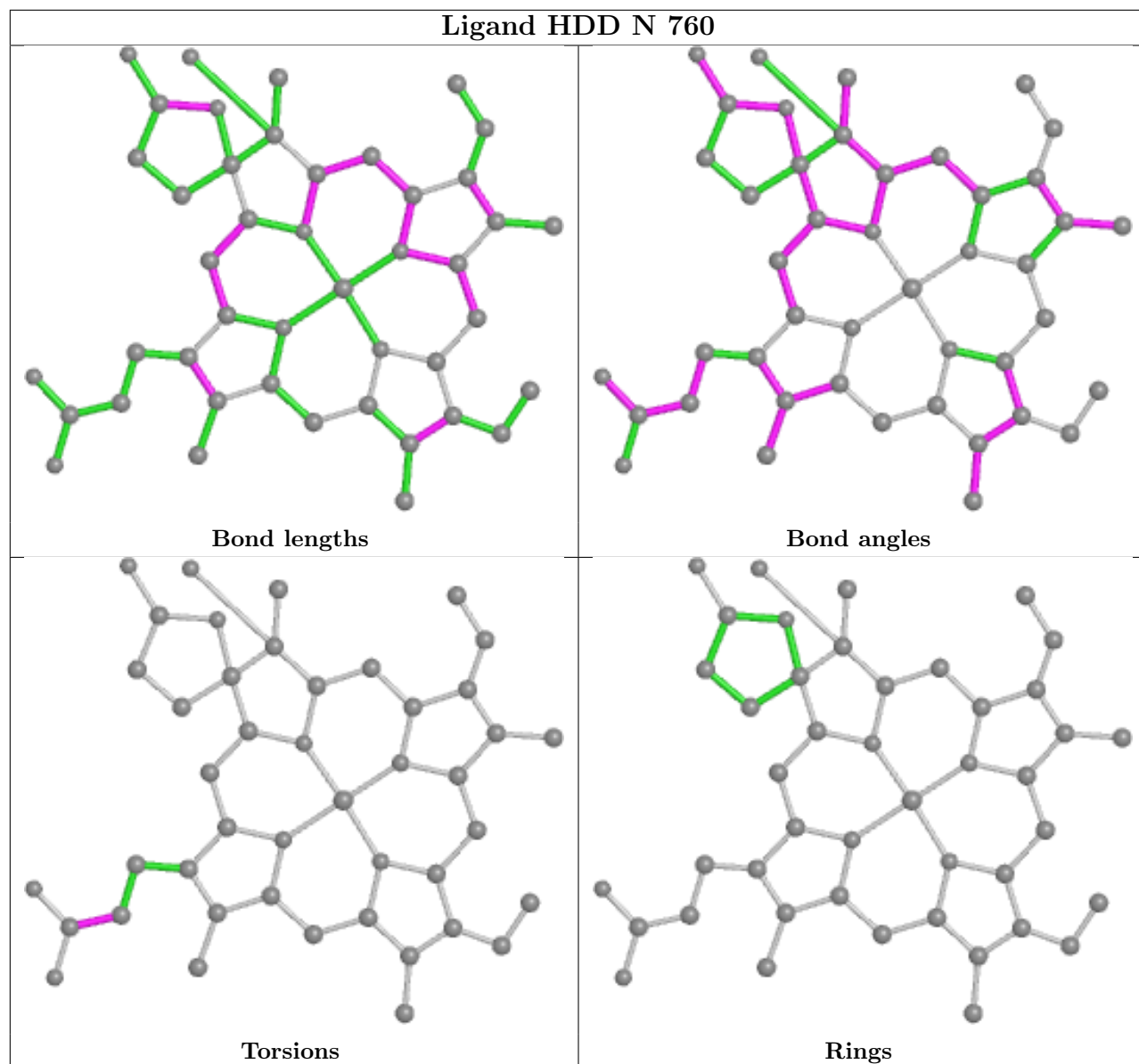

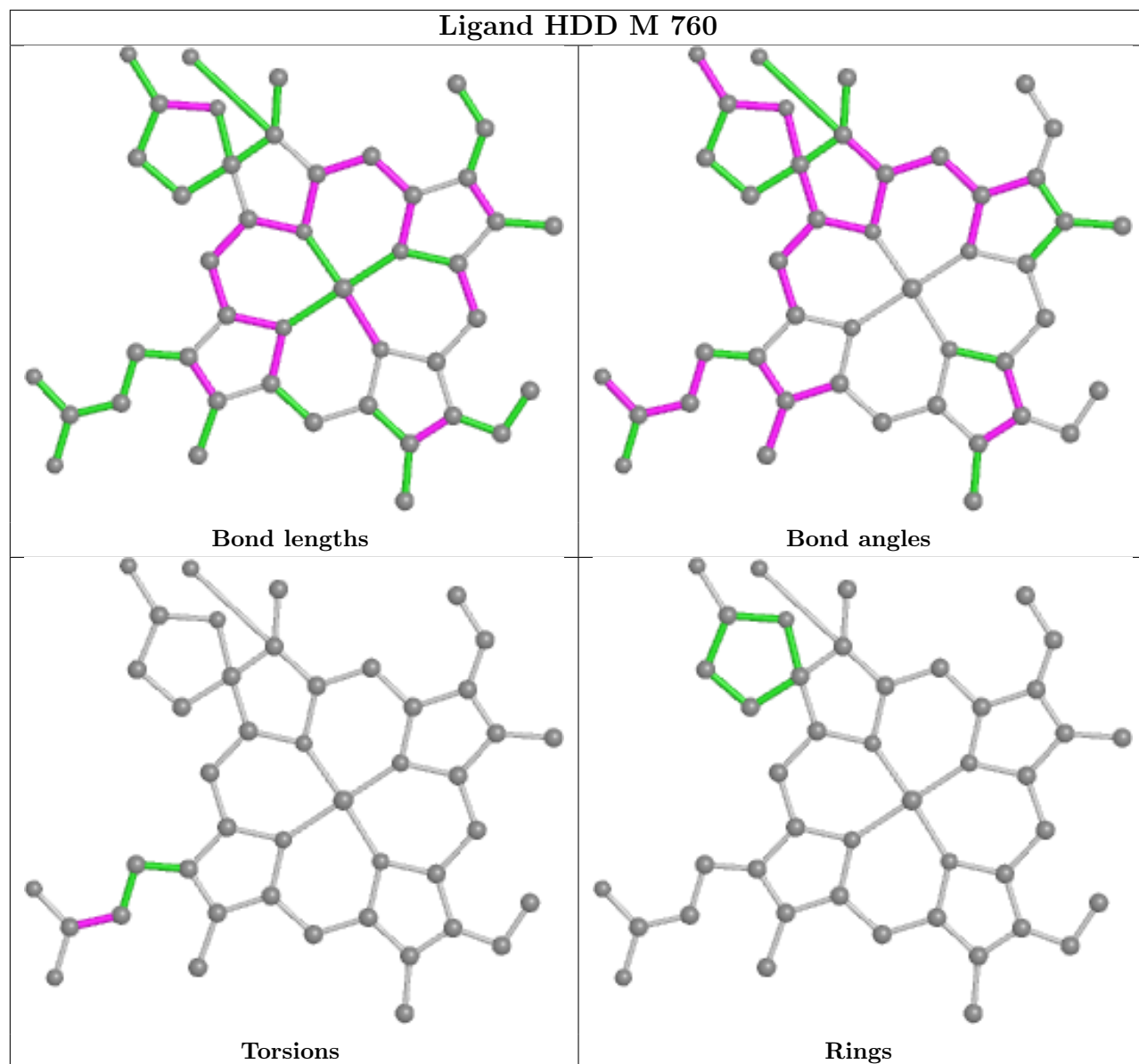

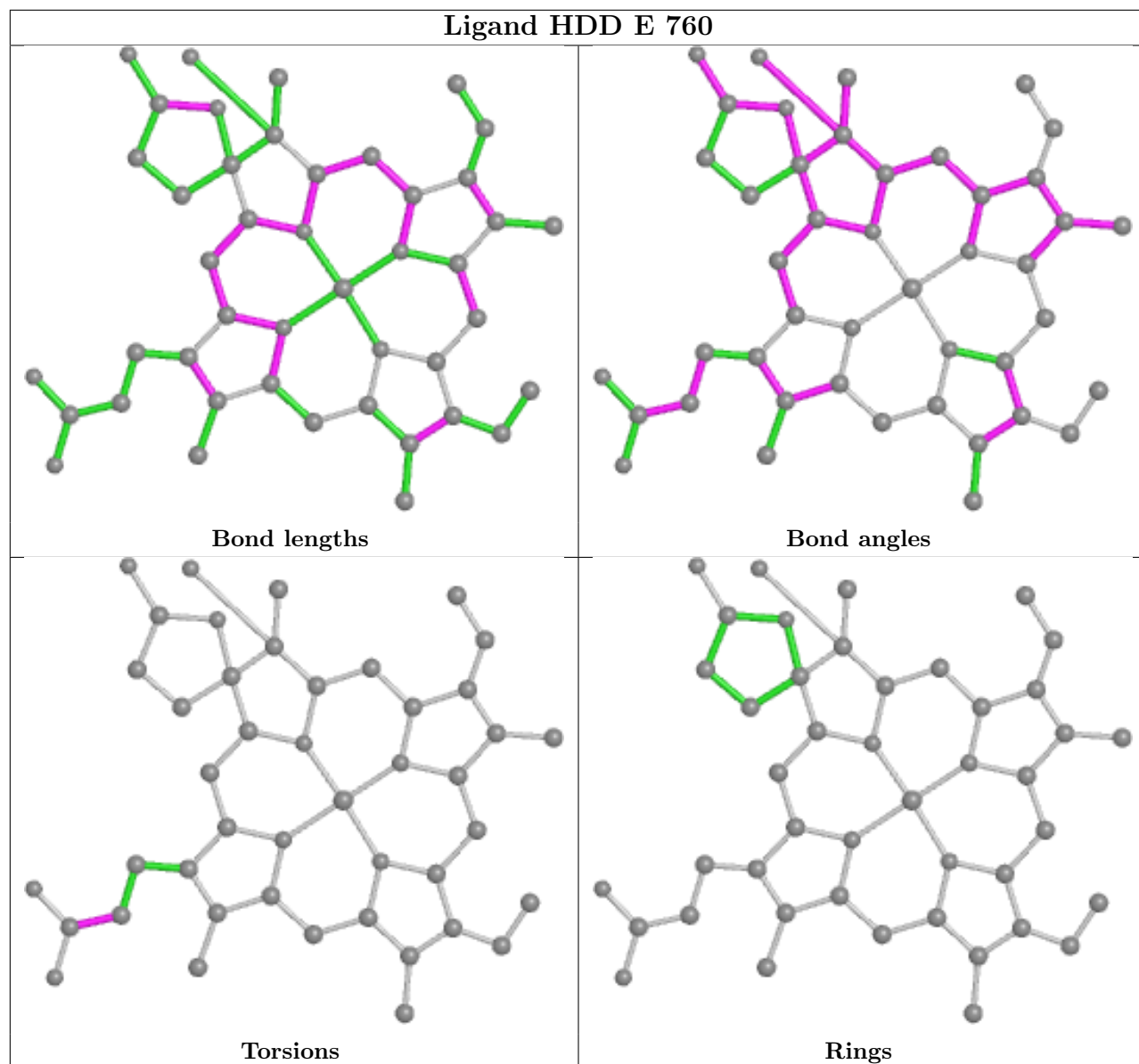

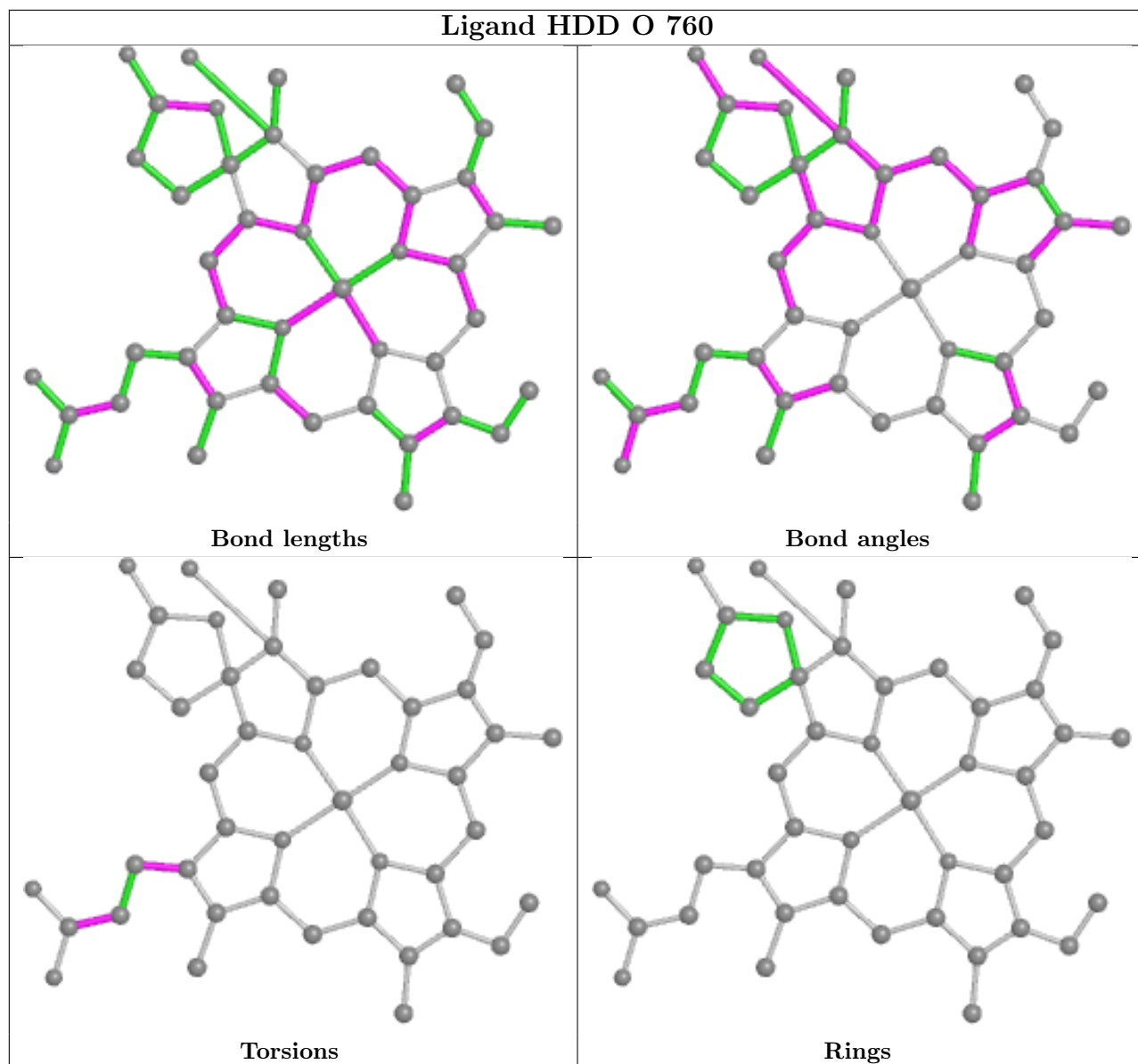

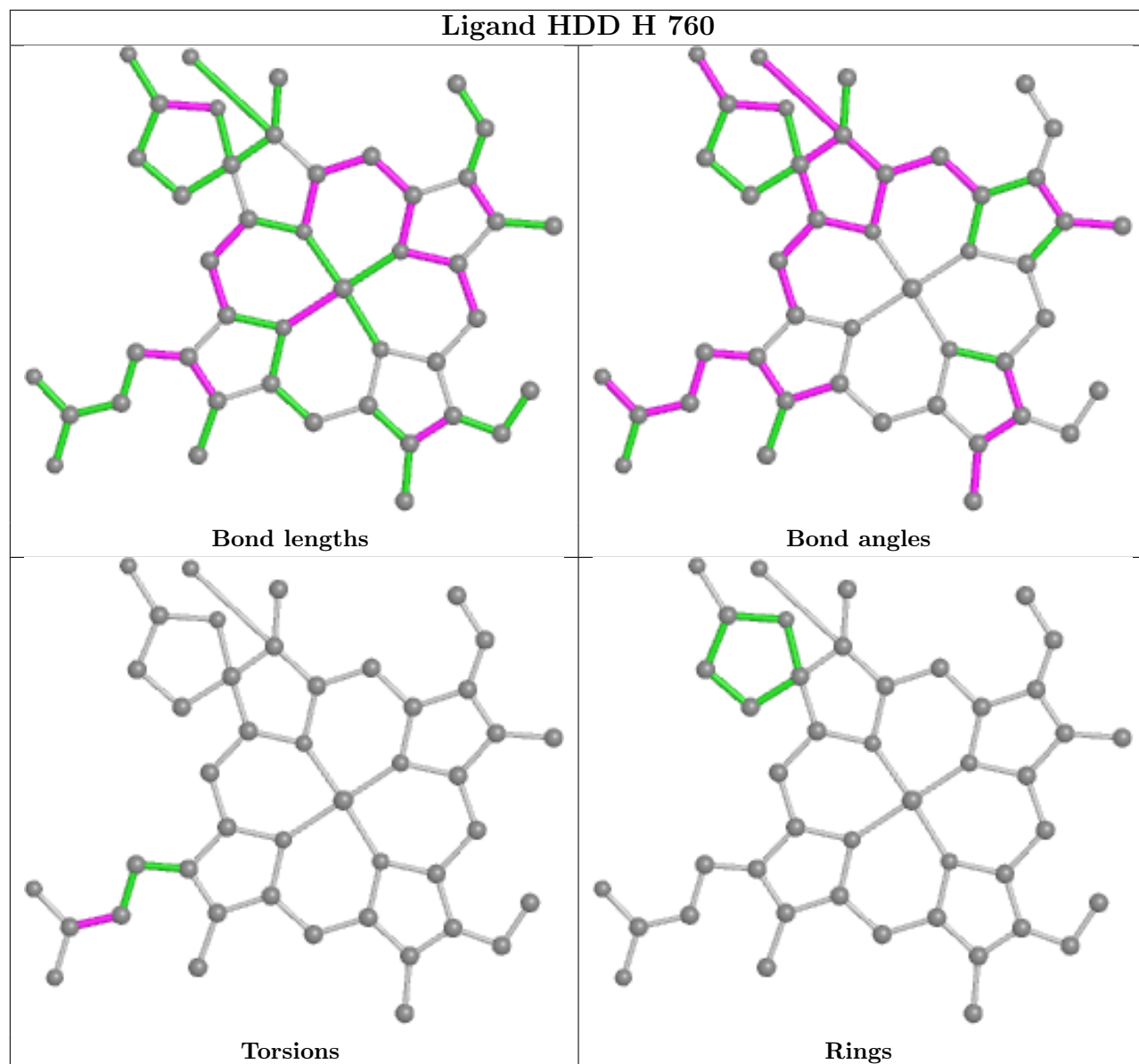

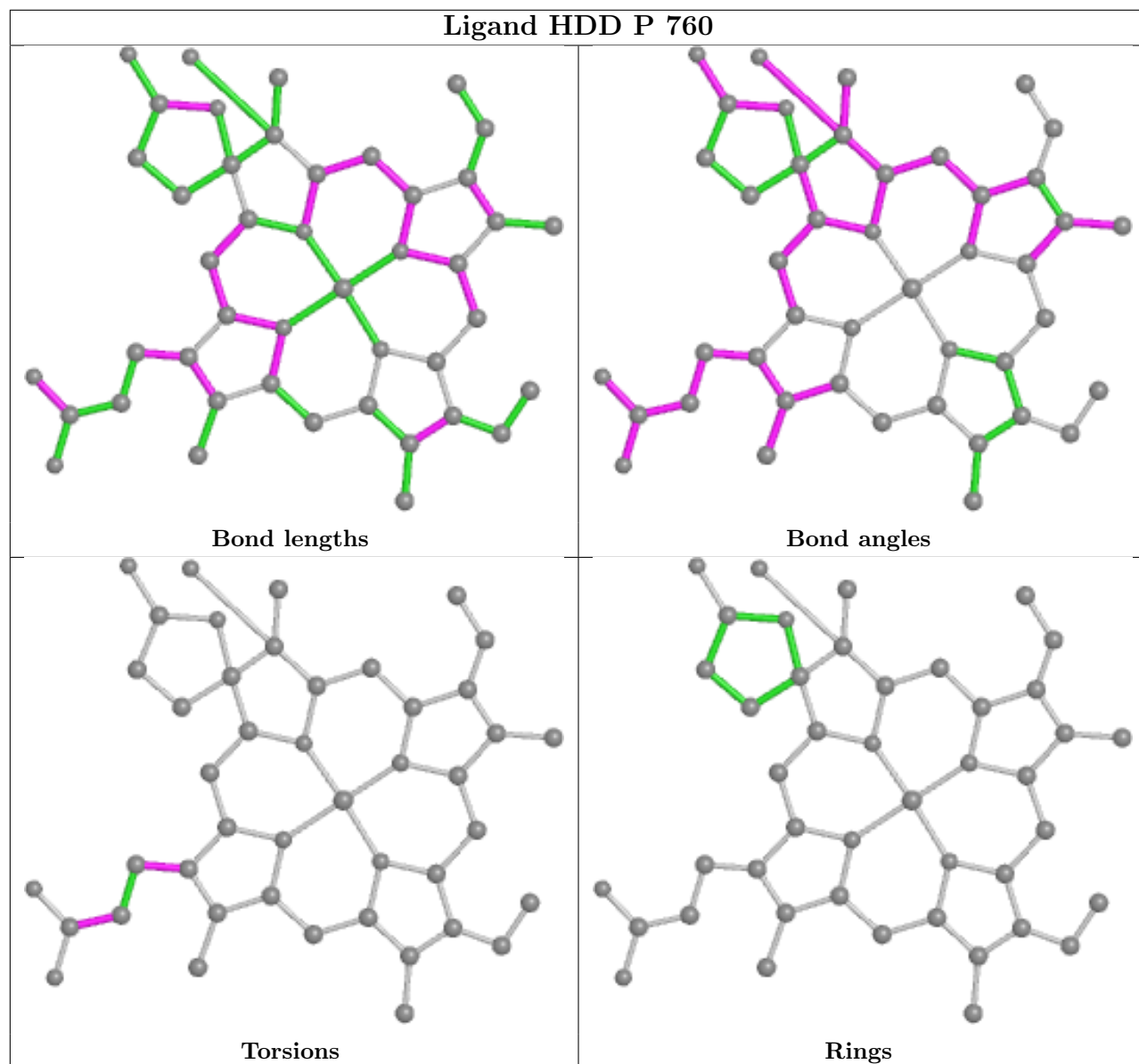

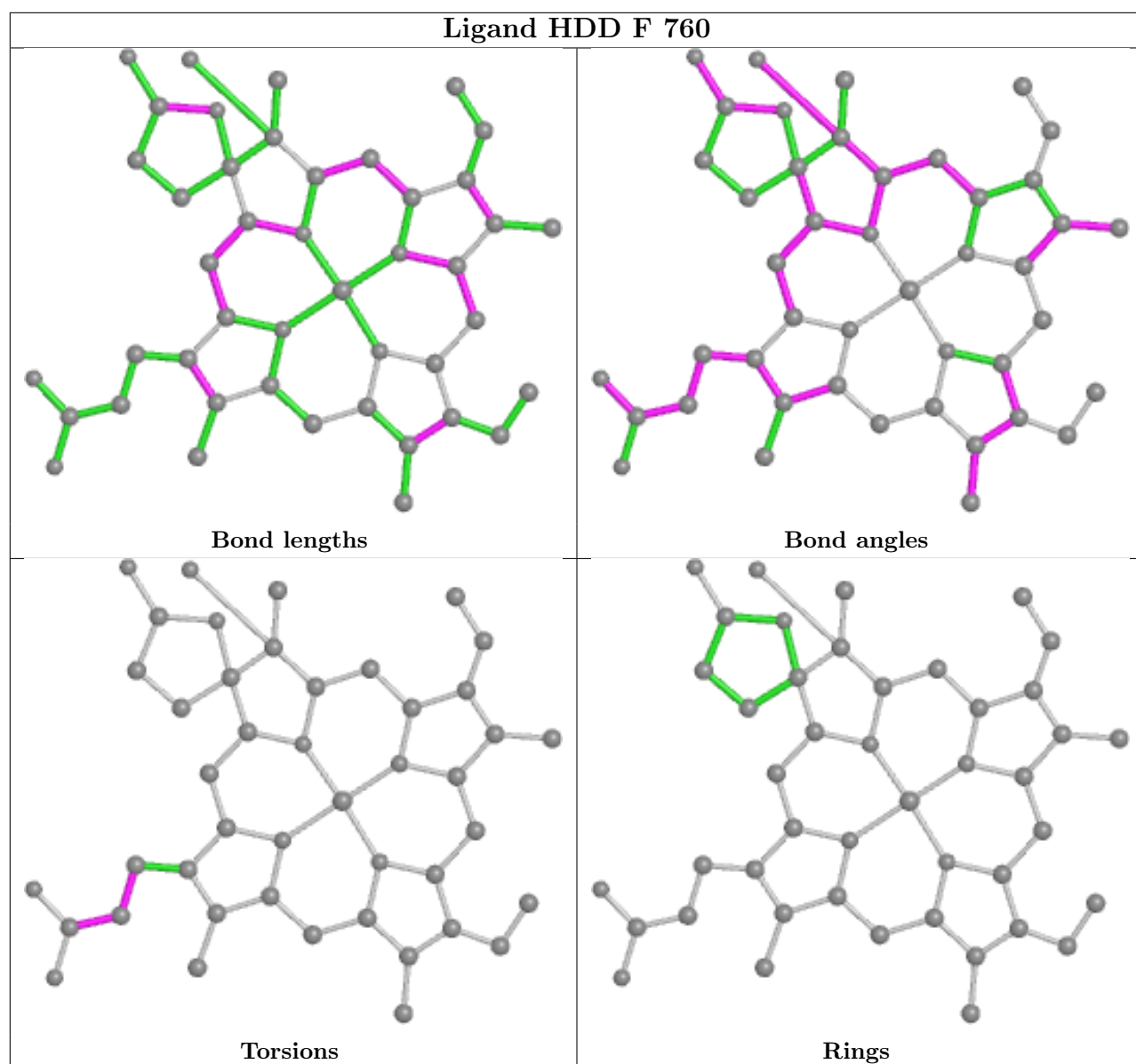

5.7 Other polymers [\(i\)](#)

There are no such residues in this entry.

5.8 Polymer linkage issues [\(i\)](#)

There are no chain breaks in this entry.

6 Fit of model and data [i](#)

6.1 Protein, DNA and RNA chains [i](#)

In the following table, the column labelled ‘#RSRZ > 2’ contains the number (and percentage) of RSRZ outliers, followed by percent RSRZ outliers for the chain as percentile scores relative to all X-ray entries and entries of similar resolution. The OWAB column contains the minimum, median, 95th percentile and maximum values of the occupancy-weighted average B-factor per residue. The column labelled ‘Q < 0.9’ lists the number of (and percentage) of residues with an average occupancy less than 0.9.

Mol	Chain	Analysed	<RSRZ>	#RSRZ>2	OWAB(Å ²)	Q<0.9
1	A	223/226 (98%)	-0.30	3 (1%) 77 72	28, 40, 51, 80	0
1	B	223/226 (98%)	-0.23	6 (2%) 54 44	28, 40, 51, 80	0
1	C	223/226 (98%)	-0.37	3 (1%) 77 72	28, 40, 51, 80	0
1	D	223/226 (98%)	-0.30	3 (1%) 77 72	28, 40, 51, 80	0
1	I	223/226 (98%)	-0.27	6 (2%) 54 44	28, 41, 53, 80	0
1	J	223/226 (98%)	-0.44	2 (0%) 84 80	28, 41, 51, 80	0
1	K	223/226 (98%)	-0.18	10 (4%) 33 23	28, 41, 53, 80	0
1	L	223/226 (98%)	-0.41	2 (0%) 84 80	28, 40, 52, 80	0
2	E	256/259 (98%)	-0.16	7 (2%) 54 44	23, 44, 61, 81	0
2	F	256/259 (98%)	-0.17	7 (2%) 54 44	29, 45, 61, 81	0
2	G	256/259 (98%)	-0.14	6 (2%) 60 51	29, 45, 61, 81	0
2	H	256/259 (98%)	-0.20	7 (2%) 54 44	29, 45, 61, 81	0
2	M	256/259 (98%)	0.01	7 (2%) 54 44	29, 45, 61, 81	0
2	N	256/259 (98%)	-0.05	13 (5%) 28 19	29, 45, 61, 81	0
2	O	256/259 (98%)	0.01	7 (2%) 54 44	30, 46, 61, 81	0
2	P	256/259 (98%)	-0.11	10 (3%) 39 29	29, 45, 61, 81	0
All	All	3832/3880 (98%)	-0.20	99 (2%) 56 46	23, 42, 59, 81	0

All (99) RSRZ outliers are listed below:

Mol	Chain	Res	Type	RSRZ
1	A	75	SER	9.4
1	L	75	SER	9.2
1	K	75	SER	8.1
2	O	312	GLY	7.9
1	B	75	SER	6.4

Continued on next page...

Continued from previous page...

Mol	Chain	Res	Type	RSRZ
2	E	311	THR	6.2
2	F	312	GLY	6.0
2	O	311	THR	5.9
2	M	310	LEU	5.9
2	O	309	LYS	5.9
2	P	311	THR	5.9
1	J	75	SER	5.8
2	E	309	LYS	5.7
1	D	75	SER	5.7
1	I	75	SER	5.6
2	M	312	GLY	5.6
2	N	311	THR	5.4
1	C	75	SER	5.4
2	H	312	GLY	5.4
2	F	311	THR	5.4
2	M	309	LYS	5.1
2	M	311	THR	5.1
2	O	310	LEU	4.7
2	P	312	GLY	4.6
2	H	311	THR	4.5
2	P	310	LEU	4.4
2	N	309	LYS	4.3
2	N	312	GLY	4.1
2	N	563	GLY	4.1
2	F	310	LEU	4.1
2	F	309	LYS	4.1
2	P	309	LYS	4.0
2	H	310	LEU	3.8
2	E	312	GLY	3.8
1	L	76	GLU	3.6
2	E	564	ILE	3.5
2	E	310	LEU	3.4
1	K	157	ASN	3.4
2	E	518	PHE	3.4
2	G	311	THR	3.4
1	K	159	ILE	3.3
2	N	502	GLY	3.3
1	K	77	ASN	3.2
1	K	264	ARG	3.1
1	C	76	GLU	3.0
1	B	264	ARG	3.0
2	G	563	GLY	2.9

Continued on next page...

Continued from previous page...

Mol	Chain	Res	Type	RSRZ
2	G	312	GLY	2.9
1	K	78	TYR	2.9
2	P	563	GLY	2.9
1	A	297	ALA	2.9
2	N	564	ILE	2.8
1	A	76	GLU	2.8
2	P	552	LEU	2.7
1	B	77	ASN	2.7
1	K	76	GLU	2.7
1	K	297	ALA	2.7
2	M	455	THR	2.6
2	M	467	ASP	2.6
2	G	518	PHE	2.6
2	N	552	LEU	2.6
1	I	297	ALA	2.5
1	B	157	ASN	2.5
1	C	297	ALA	2.5
2	P	502	GLY	2.4
1	I	264	ARG	2.4
1	B	297	ALA	2.4
1	D	297	ALA	2.4
2	M	439	PRO	2.4
2	N	499	PRO	2.4
2	G	310	LEU	2.4
2	G	564	ILE	2.3
2	P	363	GLU	2.3
1	J	264	ARG	2.3
1	K	296	LEU	2.3
1	I	157	ASN	2.3
2	H	309	LYS	2.3
1	I	76	GLU	2.2
2	H	328	ALA	2.2
1	B	76	GLU	2.2
2	O	467	ASP	2.2
2	N	310	LEU	2.2
2	P	548	ALA	2.2
2	H	478	LYS	2.2
2	F	328	ALA	2.2
2	O	344	GLU	2.2
2	O	363	GLU	2.1
1	K	285	LYS	2.1
1	I	77	ASN	2.1

Continued on next page...

Continued from previous page...

Mol	Chain	Res	Type	RSRZ
2	N	549	HIS	2.1
2	F	369	ARG	2.1
2	N	313	ARG	2.1
2	N	548	ALA	2.1
2	P	364	LEU	2.1
2	H	556	GLN	2.1
2	E	563	GLY	2.1
2	F	518	PHE	2.1
1	D	267[A]	ARG	2.0
2	N	562	LEU	2.0

6.2 Non-standard residues in protein, DNA, RNA chains [i](#)

There are no non-standard protein/DNA/RNA residues in this entry.

6.3 Carbohydrates [i](#)

There are no monosaccharides in this entry.

6.4 Ligands [i](#)

In the following table, the Atoms column lists the number of modelled atoms in the group and the number defined in the chemical component dictionary. The B-factors column lists the minimum, median, 95th percentile and maximum values of B factors of atoms in the group. The column labelled 'Q< 0.9' lists the number of atoms with occupancy less than 0.9.

Mol	Type	Chain	Res	Atoms	RSCC	RSR	B-factors(Å ²)	Q<0.9
3	HDD	F	760	44/44	0.96	0.14	10,24,39,42	0
3	HDD	H	760	44/44	0.96	0.15	31,43,49,58	0
3	HDD	M	760	44/44	0.96	0.15	24,52,64,66	0
3	HDD	O	760	44/44	0.96	0.15	32,53,62,63	0
3	HDD	P	760	44/44	0.96	0.15	12,28,43,45	0
3	HDD	N	760	44/44	0.97	0.13	25,38,47,57	0
3	HDD	E	760	44/44	0.97	0.14	10,23,34,42	0
3	HDD	G	760	44/44	0.97	0.14	24,35,48,55	0

The following is a graphical depiction of the model fit to experimental electron density of all instances of the Ligand of Interest. In addition, ligands with molecular weight > 250 and outliers as shown on the geometry validation Tables will also be included. Each fit is shown from different orientation to approximate a three-dimensional view.

Electron density around HDD F 760:

$2mF_o-DF_c$ (at 0.7 rmsd) in gray
 mF_o-DF_c (at 3 rmsd) in purple (negative)
and green (positive)

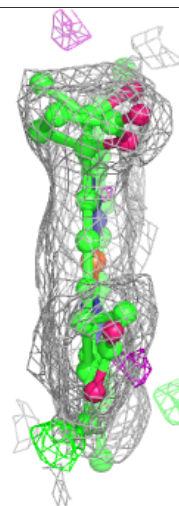
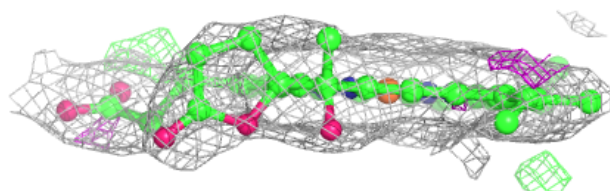
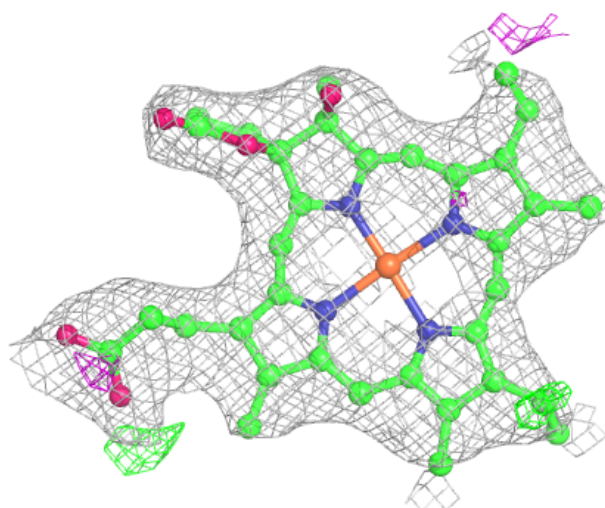

Electron density around HDD H 760:

$2mF_o-DF_c$ (at 0.7 rmsd) in gray
 mF_o-DF_c (at 3 rmsd) in purple (negative)
and green (positive)

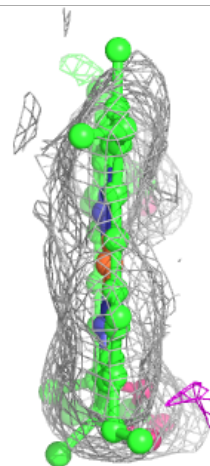
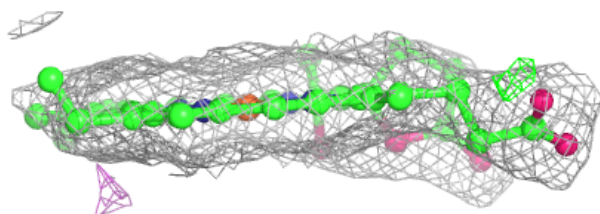
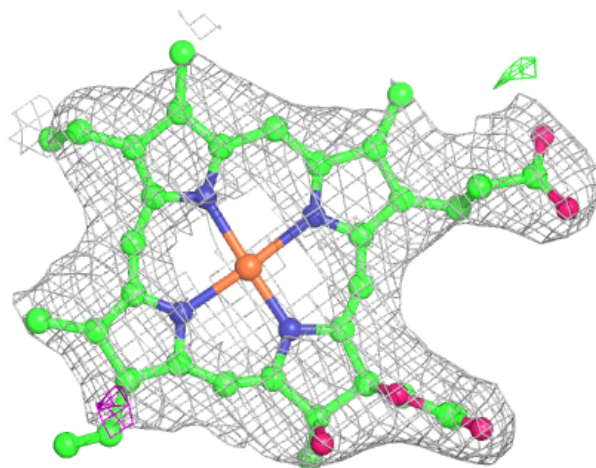

Electron density around HDD M 760:

$2mF_o-DF_c$ (at 0.7 rmsd) in gray
 mF_o-DF_c (at 3 rmsd) in purple (negative)
and green (positive)

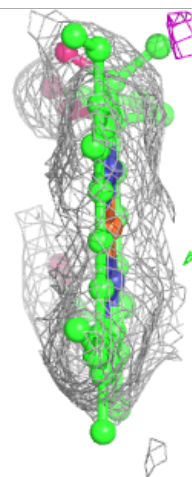
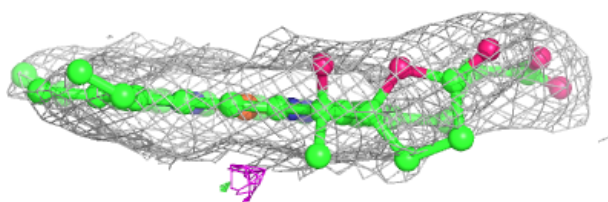
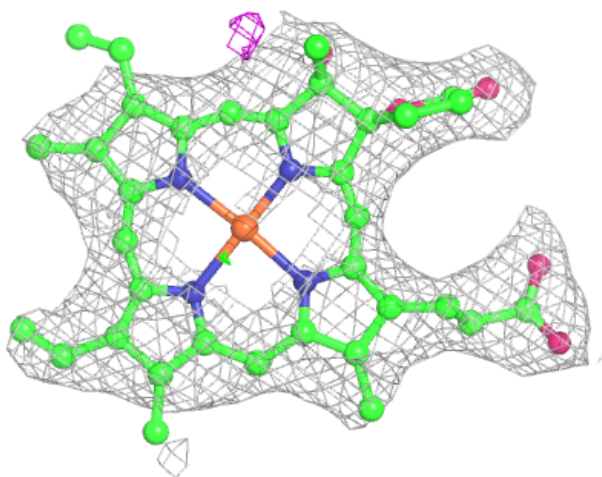

Electron density around HDD O 760:

$2mF_o-DF_c$ (at 0.7 rmsd) in gray
 mF_o-DF_c (at 3 rmsd) in purple (negative)
and green (positive)

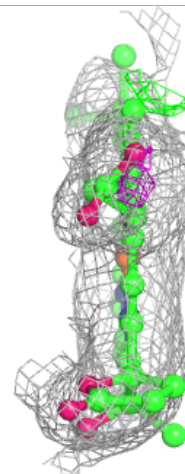
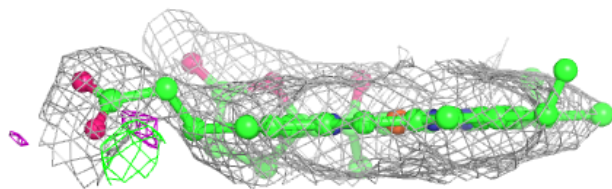
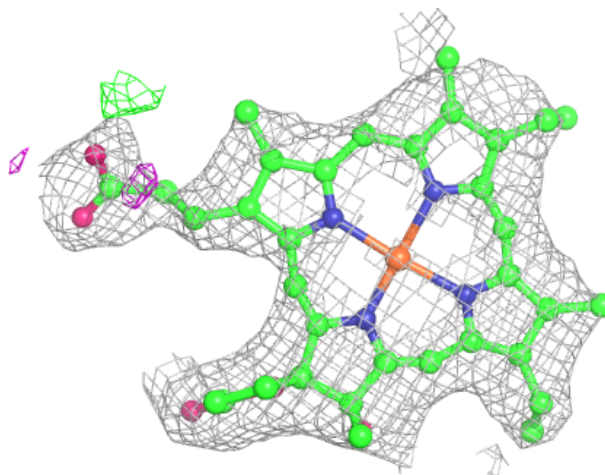

Electron density around HDD P 760:

$2mF_o-DF_c$ (at 0.7 rmsd) in gray
 mF_o-DF_c (at 3 rmsd) in purple (negative)
and green (positive)

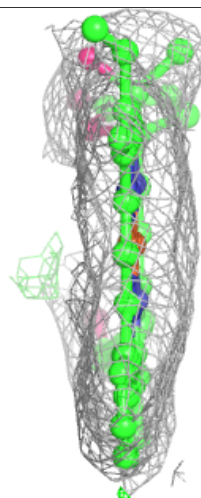
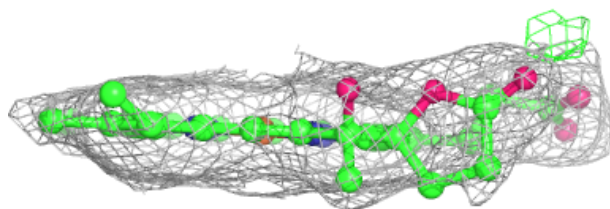
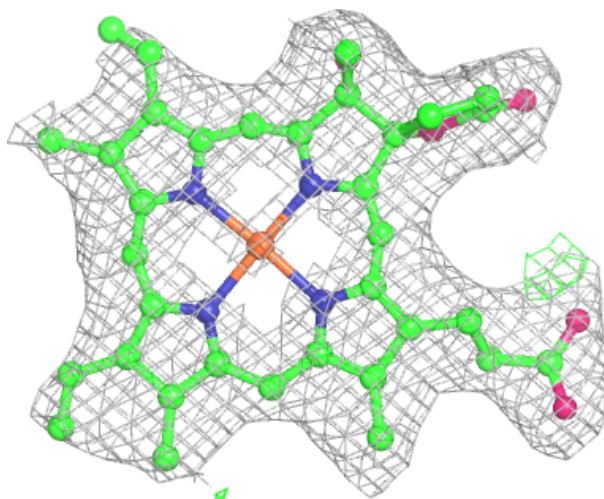

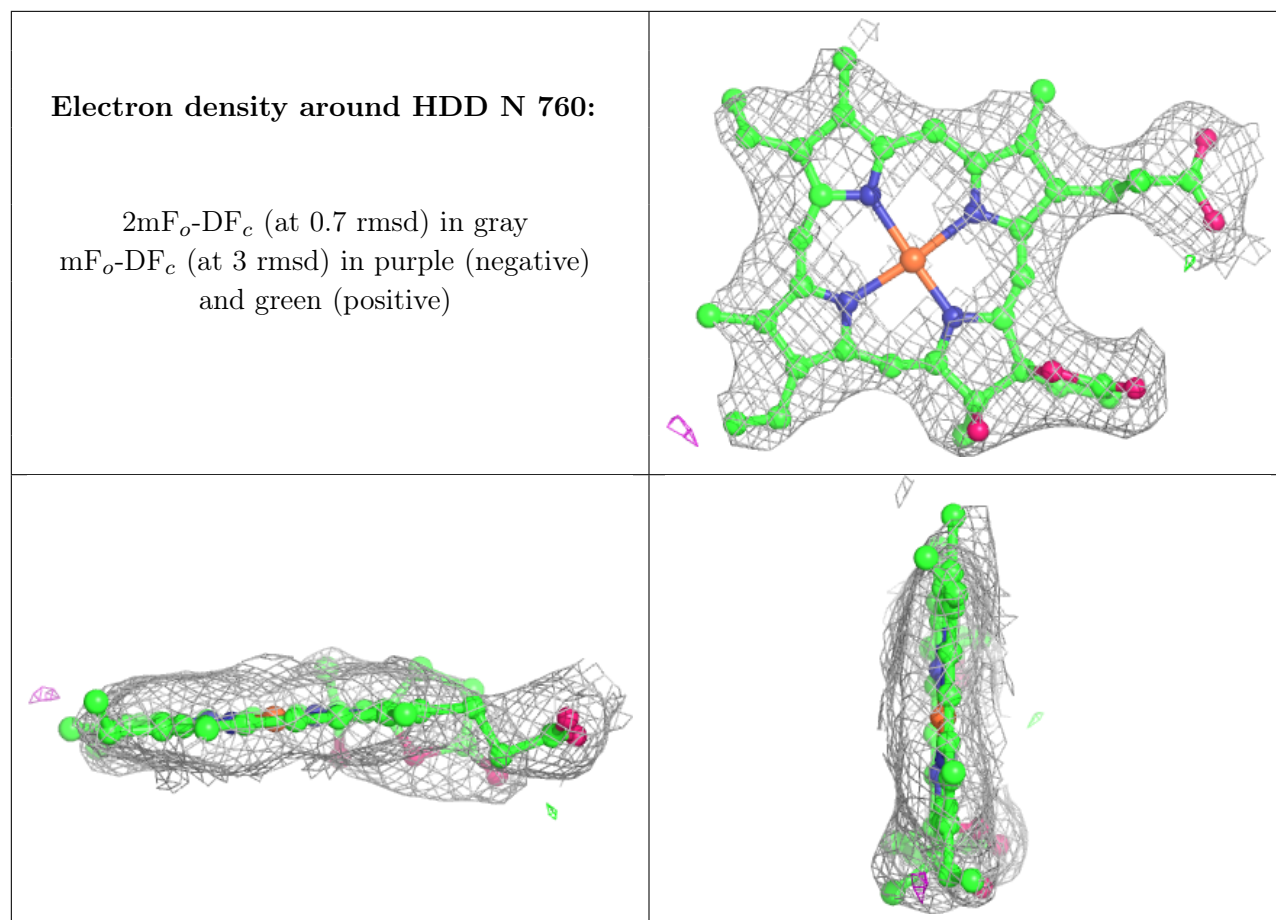

Electron density around HDD E 760:

$2mF_o-DF_c$ (at 0.7 rmsd) in gray
 mF_o-DF_c (at 3 rmsd) in purple (negative)
and green (positive)

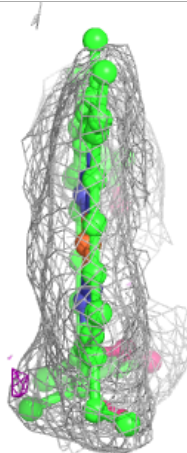
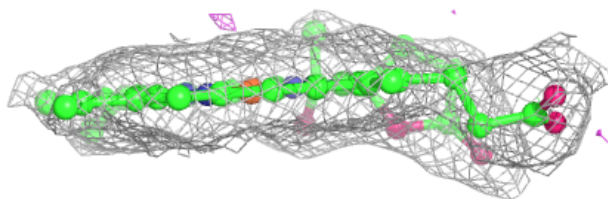
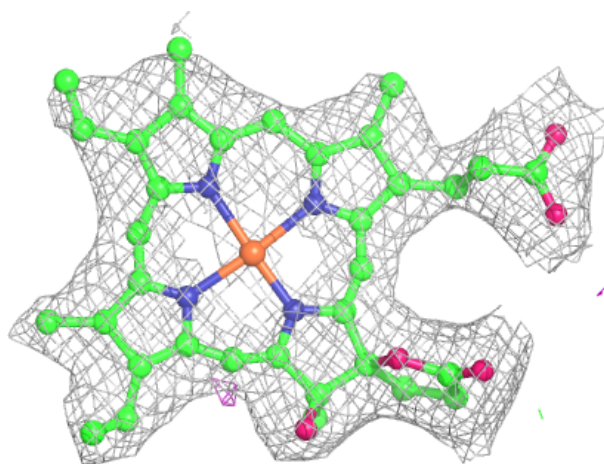

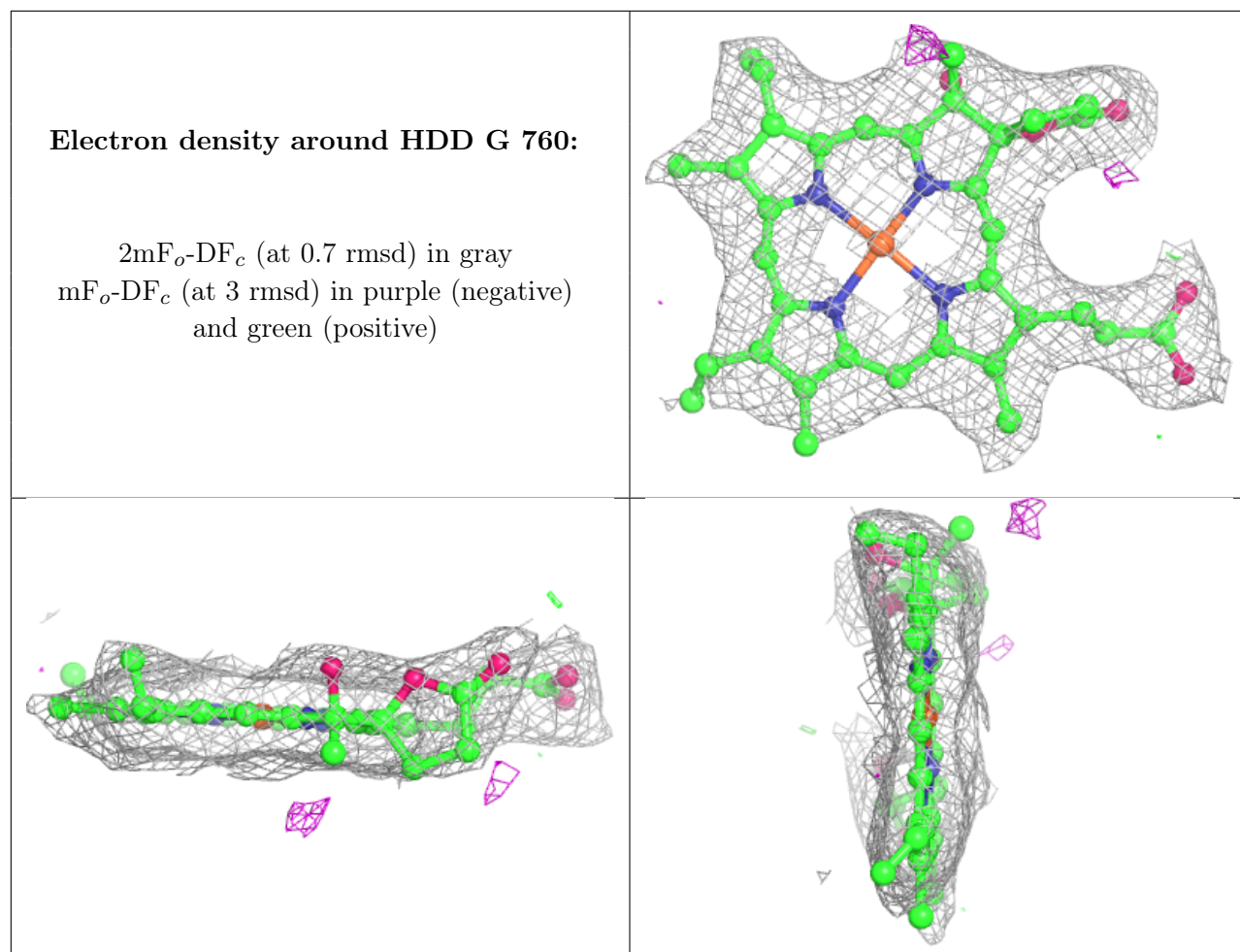

6.5 Other polymers [i](#)

There are no such residues in this entry.